

AP Placement

PROCESS FLOW SCHEMATIC

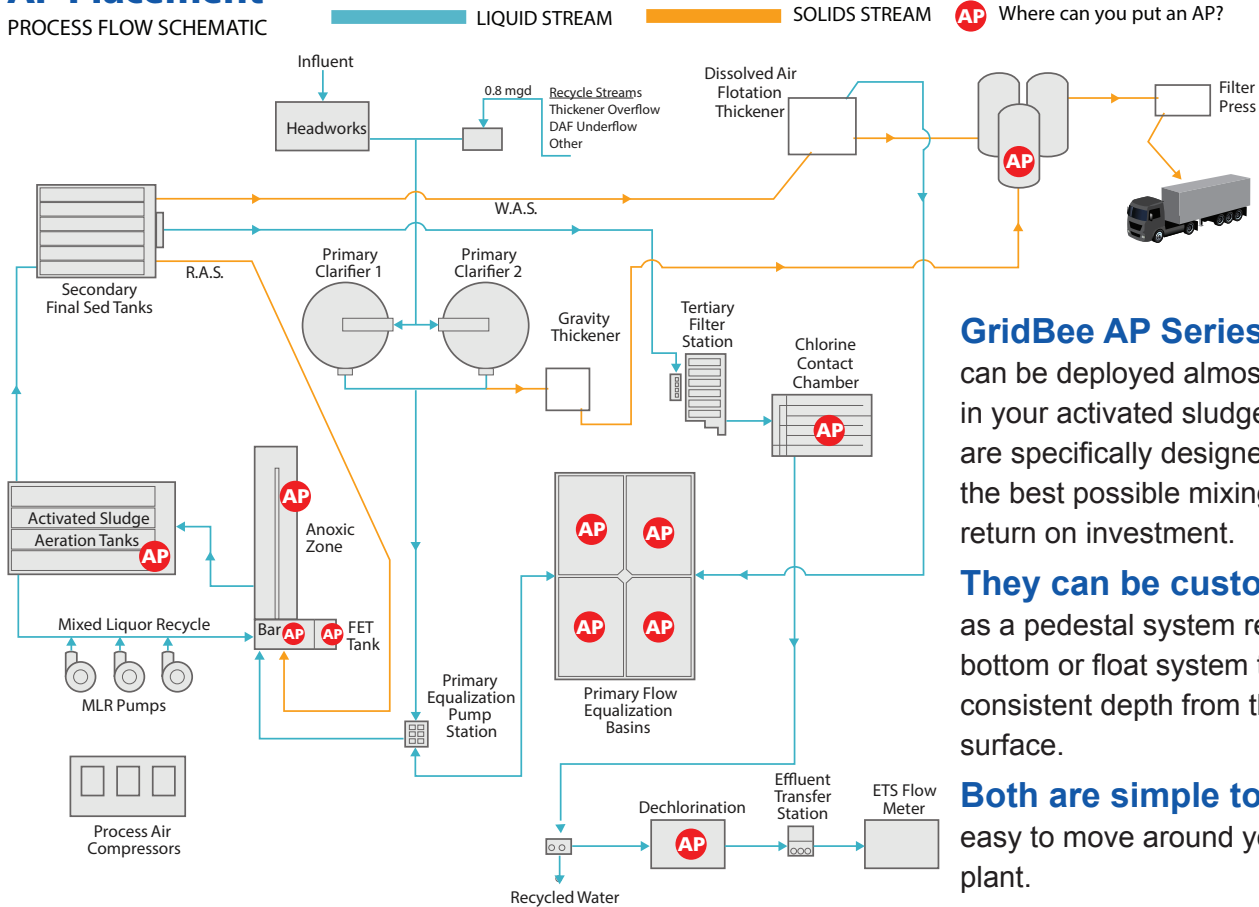

GridBee AP Series Mixers can be deployed almost anywhere in your activated sludge system and are specifically designed to provide the best possible mixing with a fast return on investment.

They can be customized as a pedestal system resting on the bottom or float system to maintain consistent depth from the water surface.

Both are simple to install and easy to move around your treatment plant.

Benefits

- Better Mixing
- Energy Savings
- Better Nitrogen Compliance
- Odor Mitigation

The Mixing You Need, Where You Need It, and With Less Energy!

Five (5) AP Models

are available to fit your application. The AP8000 is the most popular for activated sludge systems.

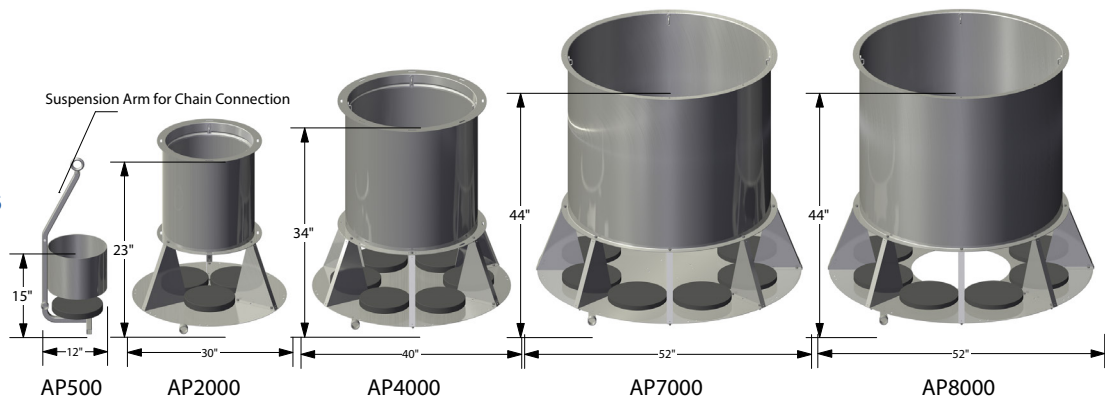

Contact Medora Corporation

for more information about how the GridBee AP Series Mixer can improve activated sludge systems!