

IXOM CHEMICAL DRUM SYSTEM

Key Product Features:

- Self-bunded with a working volume up to 500 litres
- Suitable for temporary and permanent chemical storage and dosing
- Delivered fully assembled and ready to use
- Local design and build allowing customisation to suit your application
- Compliant with ANZ standards

Suitable For Common Water Treatment Chemicals Including:

- Aluminium Sulphate
- Antiscalants, Biocides, Dispersants and other specialty chemicals
- Ferrous Chloride
- Hydrochloric Acid
- Magnesium Hydroxide Liquid (MHL)
- Sodium Hypochlorite (Hypo)
- Sodium Hydroxide (Caustic)

Ixom has developed a chemical drum system for the temporary or permanent dosing and storage of chemicals. The chemical drum system enables the dosing of common water treatment chemicals, most frequently chemicals used for cleaning in place (CIP) or neutralisation processes.

Ixom's chemical drum system is designed and manufactured in Australia using components from industry leading brands such as Grundfos and Georg Fischer. The local design and build enables customisation to your specific needs and allows for comprehensive factory testing before being supplied to site.



IXOM

Ixom Water Treatment Systems

1 Nicholson St
East Melbourne VIC 3002
Australia

T Australia
1300 559 262
New Zealand
0800 222 277
All other locations
+61 3 9906 3000
E water.treatment@ixom.com

ixomwatercare.com/ixomwts

For specialist advice in an emergency, call Ixom's
24 HOUR EMERGENCY RESPONSE SERVICE

Australia
1800 033 111

New Zealand
0800 734 607

International
+61 3 9663 2130

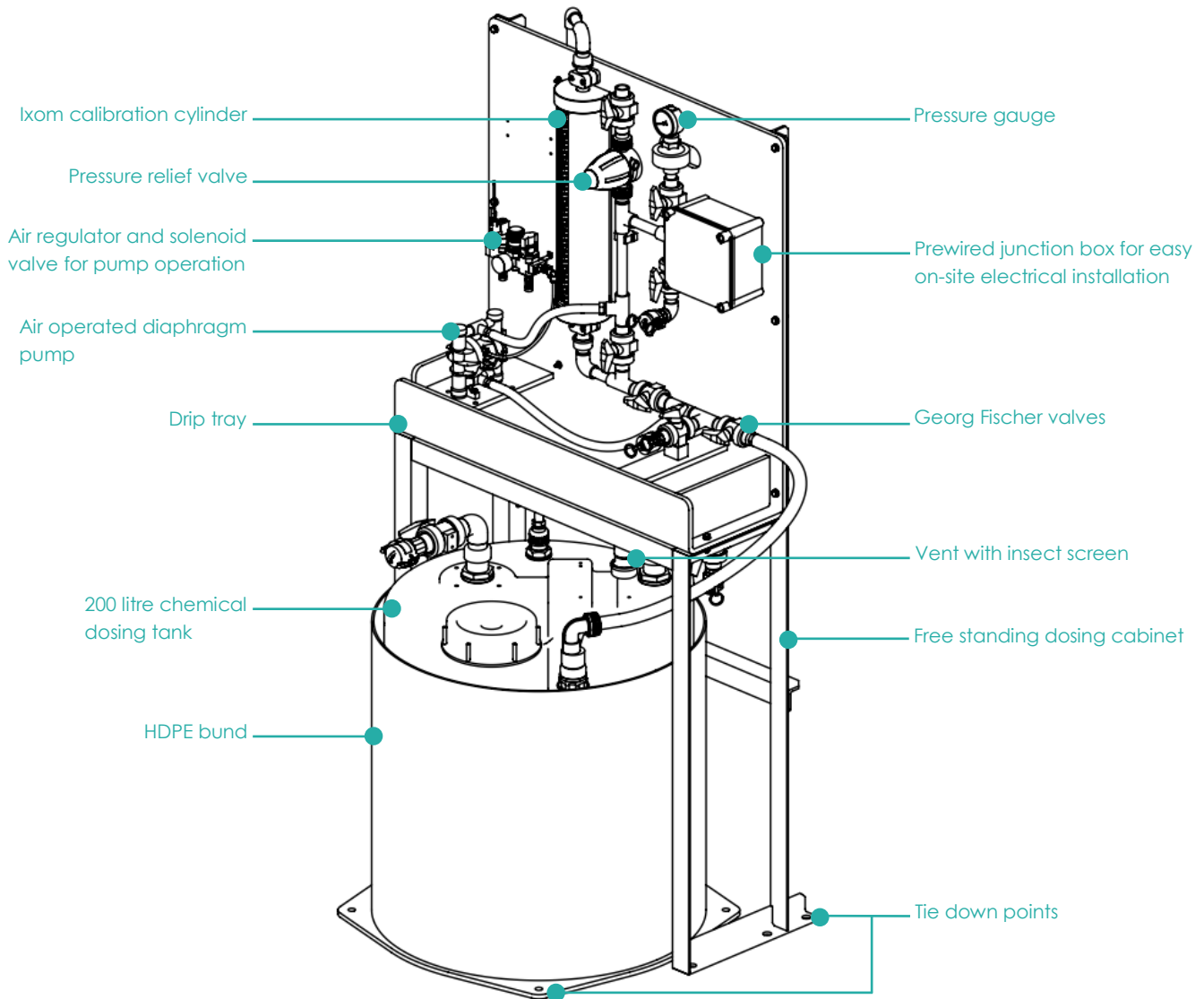

***System for CIP dosing with high flow air operated diaphragm pump shown**

Safety in Design

Each chemical drum system has been designed to incorporate Ixom's extensive knowledge and best practice in chemical storage and handling. The chemical drum system is designed in accordance with ANZ standards and developed using the IXOM HAZOP process to minimise operational and safety risks.

Configurable Product To Suit Your Application

- Dosing pumps such as digital diaphragm and air operated diaphragm
- Types/brands of equipment
- Free standing dosing cabinet
- Calibration cylinder
- Storage tank filling options

Ixom Water Treatment Systems

1 Nicholson St
East Melbourne VIC 3002
Australia

T Australia
1300 559 262
New Zealand
0800 222 277

All other locations
+61 3 9906 3000
E water.treatment@ixom.com

ixomwatercare.com/ixomwts

For specialist advice in an emergency, call Ixom's
24 HOUR EMERGENCY RESPONSE SERVICE

Australia
1800 033 111

New Zealand
0800 734 607

International
+61 3 9663 2130

What's your challenge?

Important Notice

While the information contained here is Ixom's best knowledge at the date of publication, Ixom makes no representation about the accuracy of the information. If you need clarification or more information, you should contact Ixom. Ixom's equipment and technology applications and solutions are designed to fit the specific requirements and conditions of each customer site operations. The outcomes of its equipment and technology applications may differ between operations and sites. To the extent legally permissible Ixom accepts no responsibility (including in negligence) for loss or damage of any nature resulting from the use of Ixom's products or reliance upon the information contained here. Issued by Ixom WTS, a division of Ixom Operations Pty Ltd (ABN 51 600 546 512), 1 Nicholson Street, Melbourne. Ixom and the Ixom logo are trademarks of Ixom Group.

Revision 0 released 6/07/2021. Uncontrolled if printed. Access latest version at www.ixomwatercare.com/ixomwts-productguide.