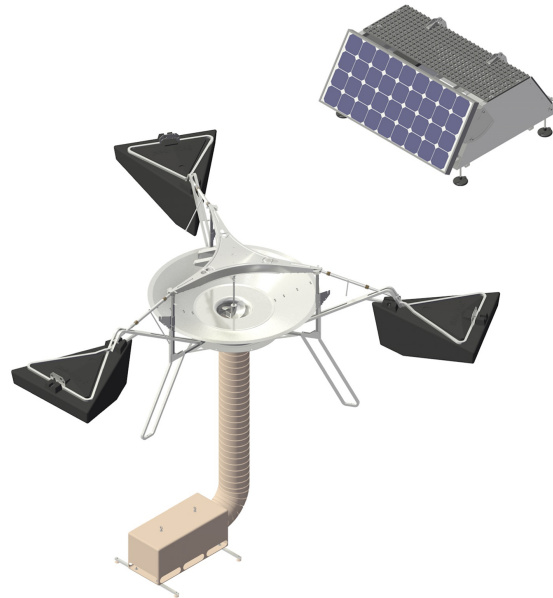


# SolarBee SB2500PW

## Owner's Manual



## Table of Contents



# SolarBee SB2500PW

## Owner's Manual

---

Safety	1
Operation	4
Site Preparation	5
Assembly	6
Features	24
Maintenance	26
Electrical	34
Troubleshooting	37
Parts Diagram	41
Dimension Drawing	42
Appendix	43
Technical Specifications	44
Warranty	58
Service Program	59
Customer Service	60

---

## Safety

# IMPORTANT

**YOU MUST COMPLETELY  
READ AND FULLY  
UNDERSTAND THESE  
INSTRUCTIONS BEFORE  
INSTALLING, OPERATING,  
OR SERVICING THIS UNIT.**

**Be sure you have read all installation, operation, maintenance and safety instructions before you install, service or begin to operate this unit.**

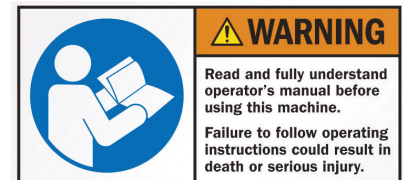
Accidents occur every year because of careless use of industrial equipment. You can avoid hazards by following these safety instructions, and applying some ordinary common sense when operating or servicing this unit.

Keep in mind that **full operator attention and alertness** are required when operating or servicing this unit.

**USE COMMON SENSE!!** Most accidents can be avoided by using **common sense and concentration** on the job being done.



Carefully read safety information when you see any safety symbols.



# Safety

## IMPORTANT

**YOU MUST COMPLETELY READ AND FULLY UNDERSTAND THESE INSTRUCTIONS BEFORE INSTALLING, OPERATING, OR SERVICING THIS UNIT.**

Identify all possible hazards. Determine what safeguards are needed and implement them. **Only you, the user,** understand your product and system characteristics fully. *The ultimate responsibility for safety is with you. Your safety ultimately rests in your hands.* Do your part and you will enjoy safe, trouble free operation for years to come. This instruction manual is not intended to include a comprehensive listing of all details for all procedures required for placement, operation and maintenance. If you have a question about a procedure or are uncertain about any detail, **Do Not Proceed.** Please contact Ixom Watercare Customer Service at **866-437-8076** to speak to a representative.



### IMPORTANT!!!

Follow all federal and state laws in regards to safety regulations of working at heights, confined spaces, rescue, etc. as required by the U.S. Department of Labor, Occupational Safety and Health Administration. Use necessary PPE when placing and servicing this unit.



### Thin Ice Hazard

**WARNING:** ICE SURROUNDING MACHINE MAY NOT SUPPORT WEIGHT, KEEP CLEAR OF THIN ICE.



### ELECTRICAL HAZARD

**WARNING:** THIS EQUIPMENT CONTAINS HIGH VOLTAGE! ELECTRICAL SHOCK CAN CAUSE SERIOUS OR FATAL INJURY. ONLY QUALIFIED PERSONNEL SHOULD ATTEMPT PLACEMENT, OPERATION AND MAINTENANCE OF ELECTRICAL EQUIPMENT. REMOVE ALL SOURCES OF ELECTRICAL POWER BEFORE PERFORMING ANY SERVICE WORK TO THE MACHINE. USE PROPER LOCKOUT TAGOUT (LOTO) PROCEDURES TO ENSURE A SAFE WORK ENVIRONMENT.



### Crush Hazard

**WARNING:** DO NOT REMOVE ANY FLOAT ASSEMBLY BOLTS OR PINS WHILE EQUIPMENT IS FLOATING IN WATER. EQUIPMENT MUST BE SECURELY SUPPORTED BEFORE PERFORMING SERVICE.



### Rotating Hazard

**CAUTION:** KEEP BODY APPENANDAGES OR LOOSE CLOTHING AWAY FROM EQUIPMENT WHILE OPERATING. ENSURE EQUIPMENT IS OFF BEFORE ATTEMPTING SERVICE.



### Entanglement Hazard

**WARNING:** ENSURE THAT PERSONNEL ARE CLEAR OF THE ELECTRIC CORD AND CHAIN TO AVOID ENTANGLEMENT.



### Laceration Hazard

**CAUTION:** EDGES MAY BE SHARP AND CAUSE LACERATION IF PROPER CARE IS NOT USED.



# Safety

## Protect Yourself

It is important that you comply with all relative OSHA and local regulations while installing and performing any maintenance to the mixer circulation equipment.

Key OSHA Compliance Standards that must be followed (and not limited to) are:

- **1910.146 Permit-required confined spaces**
- **1910.147 Lockout/Tagout**
- **1926.500 Fall Protection**

## Fall Protection Tips

- Identify all potential tripping and fall hazards before work starts.
- Look for fall hazards such as unprotected floor openings/edges, shafts, open hatches, stairwells, and roof openings/edges.
- Inspect fall protection and rescue equipment for defects before use.
- Select, wear, and use fall protection and rescue equipment appropriate for the task.
- Secure and stabilize all ladders before climbing.
- Never stand on the top rung/step of a ladder.
- Use handrails when you go up or down stairs.
- Practice good housekeeping. Keep cords, welding leads and air hoses out of walkways or adjacent work areas.

Refer to 29 CFR 1926.500 for complete regulations set by OSHA. Refer to your state's regulations if your state established and operates their own safety and health programs approved by OSHA.

## Lockout Tagout

When the On/Off switch is in the "ON" position, the mixer may start up at any time if not already operating. The mixer's On/Off switch can be locked out by placing a pad lock thru the door latch of the controller after the switch has been turned to the "OFF" position. The On/Off switch is to be used as the emergency stop.



## Permit-Required Confined Spaces

A confined space has limited openings for entry or exit, is large enough for entering and working, and is not designed for continuous worker occupancy. Confined spaces include underground reservoirs, ground storage tanks, elevated tanks, silos, manholes, and pipelines.

## Confined Space Tips

- Do not enter permit-required confined spaces without being trained and without having a permit to enter.
- Review, understand and follow employer's procedures before entering permit-required confined spaces and know how and when to exit.
- Before entry, identify any physical hazards.
- Before and during entry, test and monitor for oxygen content, flammability, toxicity or explosive hazards as necessary.
- Use fall protection, rescue, air monitoring, ventilation, lighting and communication equipment according to entry procedures.
- Maintain contact at all times with a trained attendant either visually, via phone, or by two-way radio. This monitoring system enables the attendant and entry supervisor to order you to evacuate and to alert appropriately trained rescue personnel to rescue entrants when needed.

Refer to 29 CFR 1910.146 for complete regulations set by OSHA. Refer to your state's regulations if your state established and operates their own safety and health programs approved by OSHA.

## Operation

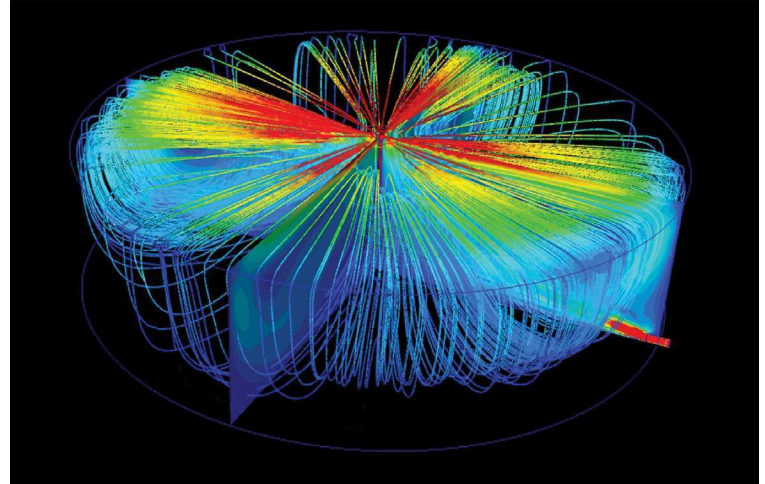
## Operation

### SB Series

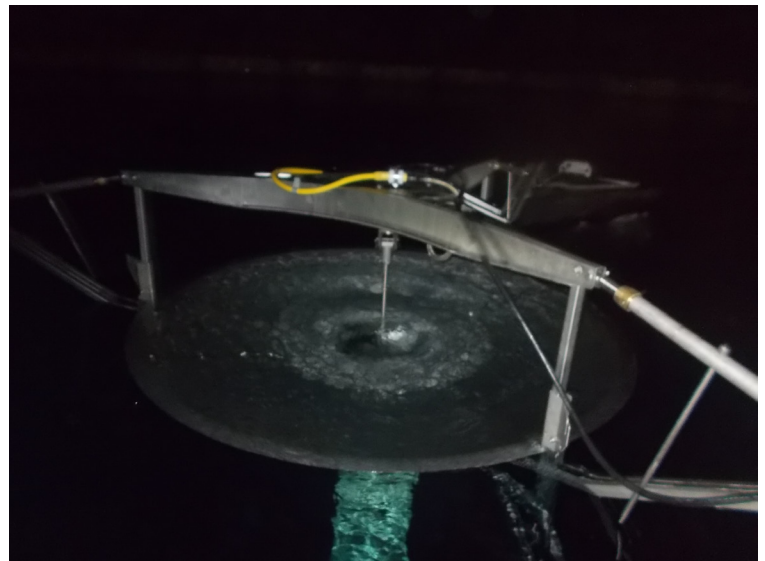
The SolarBee is designed to circulate water by bringing water from below and sending it out across the top in a thin layer causing a mixing effect. The laminar layer flows outward radially, in diverging “stream lines” from the distribution dish. As it does, vertical flow is induced in between the water being drawn below and the water above. At the level of the flow intake, water is drawn from all corners of the tank. As this lower layer of fluid makes its way inward with converging streamlines to the SolarBee, the water is forced upward, toward the surface, providing gentle mixing and de-stratification.

The SolarBee obtains all the energy it needs from the sun. Its solar panels provide power to the onboard battery which energizes the drive system’s controls and motor. Excess solar energy is stored during the day and used during the night allowing the SolarBee to operate during the night without being connected to the grid.

During operation, a visible flow can be observed coming off the distributor dish and spreading outward. The impeller of the SolarBee is designed to operate at full speed when there is sufficient sunlight and battery charge. The rpms may drop down some during the later night and early morning when the battery uses up its charge after a longer period of overcast days. In severe sunlight limited conditions, the machine may slow down or stop temporarily to protect the battery from damage.



*SolarBee Series Flow Model*



*Flow Coming Off Distribution Dish*

## Install Site Preparation

# Install Site Preparation

Properly planning out the job site before proceeding is very important to performing an efficient and successful potable water equipment installation. Every potable water tank and reservoir is unique and therefore the following are general guidelines and considerations that will need to be evaluated for each specific site.

### HATCH REQUIREMENTS

Hatches with a clear opening of at least 6 feet X 6 feet (1.83 m X 1.83 m) will allow the core unit assembly to be installed without major disassembly required.

For smaller hatches, a clear, unobstructed opening of at least 3 feet X 3 feet (0.92m X 0.92m) is required to fit the machine components through when broken down into its smallest possible size.

### WET OR DRY INSTALLATION

A decision will be required to either install the machine while the reservoir is empty or filled with water.

Wet installations are generally preferred when the units are installed by our factory installers to allow for proper final adjustments and settings during startup which directly follows installation. Our factory installation teams have extensive training and many installation tools to assist in a wet installation.

If proper equipment and safety training are not available, a wet installation may not even be possible, and therefore a dry installation may be required and startup will have to follow at a later time once the reservoir is filled with water.

### SANITARY REQUIREMENTS

For potable water equipment installations, it is very important to maintain sanitary conditions by properly disinfecting all equipment and personnel that come into contact with the reservoir interior and potable water. It is recommended that once the hatch is chosen for equipment and personnel entry, a clean zone be designated around the hatch. The clean zone establishes a boundary where anything that comes in contact with that zone, shall be sanitary and adequately disinfected, allowing it to pass through the clean zone and into the reservoir. Standard practice in the United States is to use a 200 part per million sodium hypochlorite in water solution as a disinfectant to all equipment and personnel clothing/footwear coming into contact with the reservoir interior and potable water.

### SAFETY

Prior to commencing installation and finalizing on the installation work areas, the jobsite should be evaluated for all safety hazards including, but not limited to: Confined Space Entry, Fall Protection, Working Over Water, Overhead Equipment, Communicatoin Barriers, Equipment Handling, etc.

Once safety hazards are identified, hazard mitigation measures should be taken and safety training procedures must be practiced to accomplish the installation without incident.

# Equipment Assembly

## Core Unit Disassembly

### ••• IMPORTANT •••

The following pages give detailed instructions on how to assemble different portions of the machine, however, the order in which the components are assembled may need to be altered based on the hatch size and whether the reservoir will be dry or empty. For instance, the hose and intake assembly can be performed on the tank exterior prior to lowering the equipment inside if the hatch size is at least 6 feet X 6 feet (1.83 m X 1.83 m) which will allow the core unit assembly to be installed without major disassembly required. For smaller hatches, the core unit will need to be broken down into 3 primary components and the hose and intake assembly will need to be performed inside the reservoir. The following order listed is based on a dry installation and small hatch opening.

#### TOOLS REQUIRED:

- 13mm Wrench
- 13mm Socket Wrench
- 19mm Wrench
- 19mm Socket Wrench

#### Impeller Removal

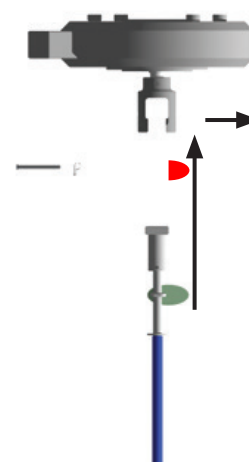
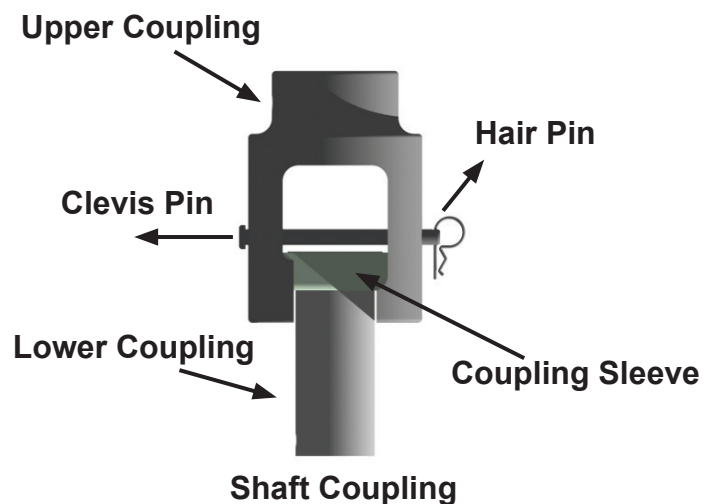
During most potable reservoir installations, it is recommended that the impeller be removed if the equipment is passing through a small hatch and will be orientated sideways or disassembled.

**STEP 1:** First identify the impeller assembly components shown to the right.

**STEP 2:** With the machine off, locate the clevis pin going through the upper shaft coupling. Remove the hair pin and pull clevis pin out.

**STEP 3:** Grab the impeller shaft below the flag indicator, lift up and then outward until lower coupling and shaft are disconnected from upper coupling and brushless motor.

**STEP 4:** Place the Impeller Assembly off to the side and re-insert the Clevis Pin and Hair Pin into the Upper Coupling for safe keeping.



Impeller Assembly Removal Motion



## Core Unit Disassembly (Cont.)

**STEP 1:** First identify the Core Unit Assembly Components shown to the right.

**STEP 2:** Remove the three M12 Bolts holding the Tri-Frame to the Lower Core Unit Legs and remove the Tri-Frame from the Core Unit by lifting upward.

**STEP 3:** On the same half of the Split Dish, remove four of the M8 Bolts for each Split Dish Flat to separate the Lower Core Unit into two halves. The Split Dish Flats can remain connected to one half as long as the hatch opening is large enough.

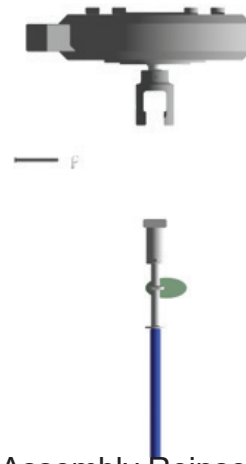
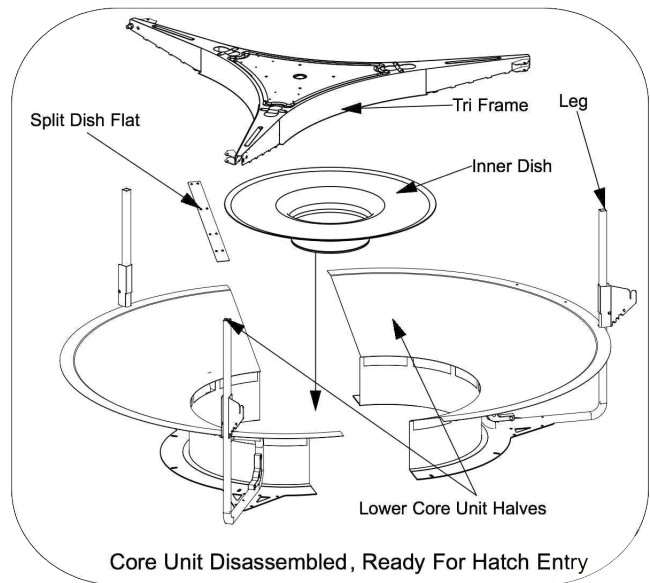
**STEP 4:** The Core Unit Assembly is now broken down into it's smallest form and each component will fit through a hatch with clear, unobstructed opening of at least 3 feet X 3 feet (0.92m X 0.92m).

**STEP 5:** Once these components are lowered through the hatch, they can be reassembled using the opposite order of STEPS 1-4.

### Impeller Reinsertion

**STEP 1:** Place impeller assembly back in place (Slide lower coupling into upper coupling and allow to drop down into place). Be sure bottom of impeller shaft fits into the bushing in the dish and that the coupling sleeve is in place inside the shaft coupling assembly.

**STEP 2:** Place clevis pin back through upper shaft coupling and secure with hair pin.



Impeller Assembly Reinsertion Motion

## Float Assembly

After familiarizing yourself with all the components and gathering the necessary tools, you are ready for setting up the machine unit. Find a location where you have approximately 20 ft of working space near the reservoir that the machine will be put in (The less distance you have to move the fully assembled machine, the better). Follow these steps to prepare the machine before floating it in the water:

### NO TOOLS REQUIRED

**STEP 1:** Locate one float, one float arm, one float bracket, and 2 float pin sets. Observe that there are two slots on the top of the float which fit around the float arm. One slot runs left and right, the other runs front to back. If float pins are in the slots, remove them.

**STEP 2:** Orientate the float so that it will fit around the float arm when the float is raised into place.

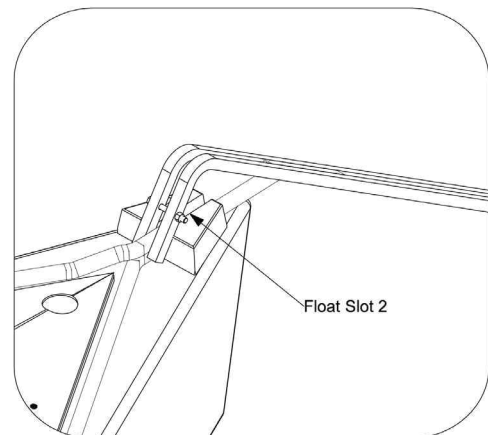
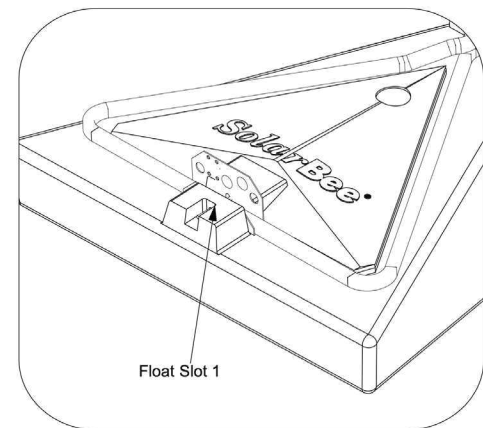
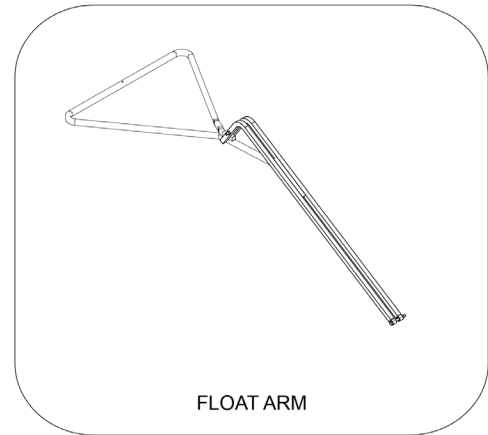
**STEP 3:** Place the float plate into float slot 1 furthest from the core unit assembly aligning the holes of the float slot with the small holes on the float plate (see photo).

**STEP 4:** Once the float plate is in place on the float, raise the float up fitting it into the float arm. Use the float pins to secure the float to the float arm.

**STEP 5:** Place hairpins in each float pin to secure it and prevent the pin from coming out.

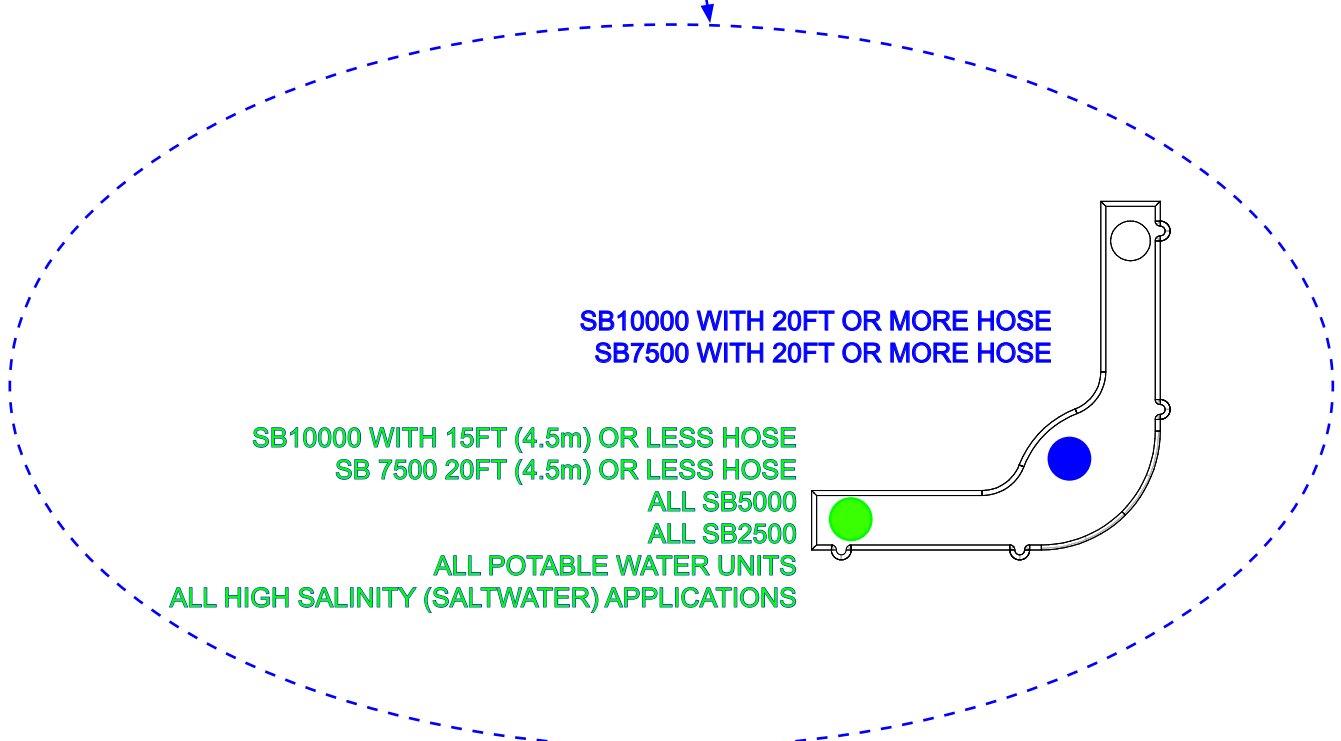
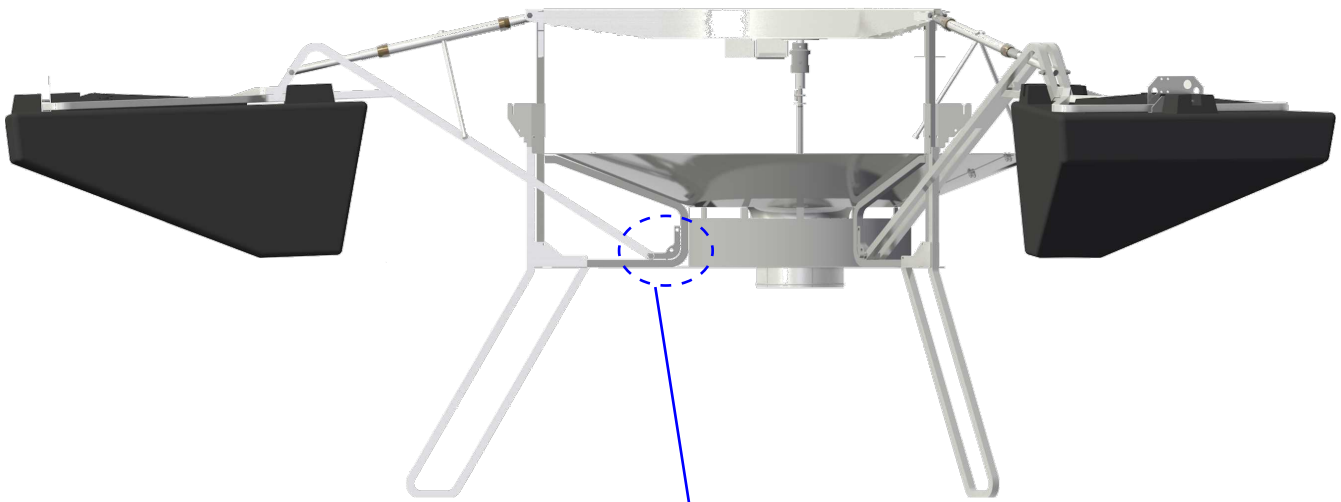
**STEP 6:** Repeat Steps 1 through 5 for the other two floats.

**NOTE:** The float plate may not be used on one of the three floats.



## Float Arm to Machine Attachment Assembly

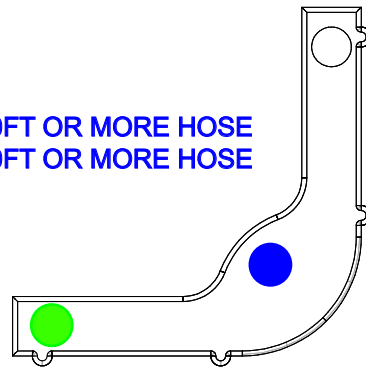
**IMPORTANT:** IF WRONG CONNECTION HOLE IS USED, DISH DEPTH LEVEL MAY NOT BE OBTAINED DURING FINAL SETTINGS AND UNIT WOULD HAVE TO BE PULLED BACK OUT OF THE WATER, CORRECTED, AND RE-INSTALLED



**SB10000 WITH 20FT OR MORE HOSE**  
**SB7500 WITH 20FT OR MORE HOSE**

**SB10000 WITH 15FT (4.5m) OR LESS HOSE**  
**SB 7500 20FT (4.5m) OR LESS HOSE**  
**ALL SB5000**  
**ALL SB2500**

**ALL POTABLE WATER UNITS**  
**ALL HIGH SALINITY (SALTWATER) APPLICATIONS**



## Float Arm Assembly

### TOOLS REQUIRED:

(2) 19mm wrench  
19mm socket wrench (optional)

**STEP 1:** Reference the previous page to select which float arm connection hole is required for your machine.

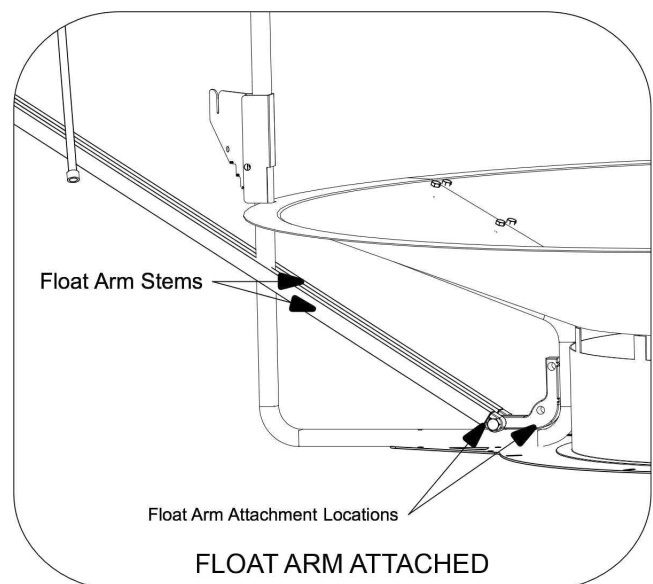
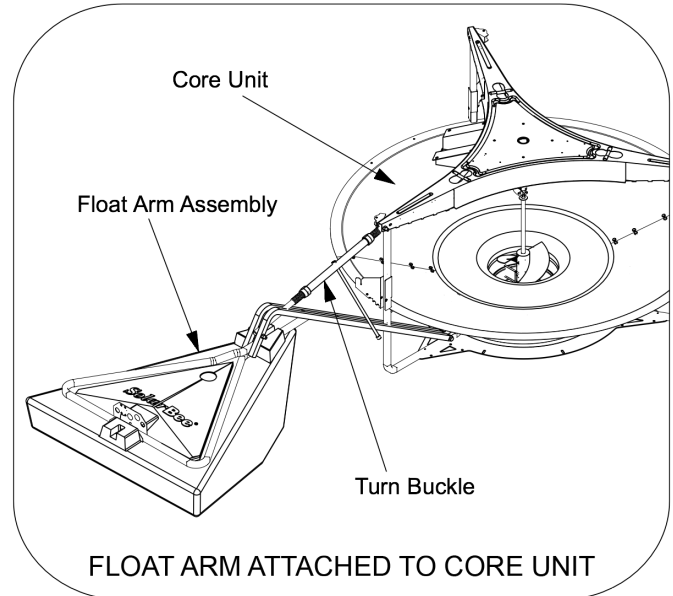
**IMPORTANT:** Be sure to use the proper hole to avoid a prolonged installation.

**STEP 2:** Locate the 3 float arm assemblies. Have the M12 x 90mm long bolts and M12 nylok nuts easily accessible near the core unit assembly.

**STEP 3:** Take the float arm and slip the narrow end with Float Arm Stems around the core unit leg. Align the holes through the Float Arm Stems with the correct float arm connection hole determined from Step 1.

**STEP 4:** Once aligned slide the M12 X 90mm bolt through all holes. Tighten a M12 nylok nut onto the bolt until there is little play or space between the bolted components. Use a two 19mm wrenches to tighten nut.

**STEP 5:** Repeat steps 2 and 3 for the other 2 float arms.





## Turnbuckle Assembly

### ••• IMPORTANT •••

Hold the center of the turnbuckle assembly and turn both ends all the way into the center. Skipping this step will cause decreased extension of turnbuckle and more time to install may be required.

#### NO TOOLS REQUIRED:

**STEP 1:** Locate the three turnbuckles, M12 90mm Bolts, M12 55mm Bolts, and Nylok Nuts.

**STEP 2:** Notice that the turnbuckle assembly has an end with a smooth shaft and the other end with threaded shaft.

**STEP 3:** Take the threaded shaft end of the turnbuckle assembly and slip it into the Triframe of the core unit assembly. Align the holes and slide the M12 55mm Bolt into position and tighten the Nylok nut.

**STEP 4:** Once the upper part of the turnbuckle assembly is in place, take the opposite end of the turnbuckle and slide it into the float arm assembly as shown in picture.

**STEP 5:** Align the hole through the shaft with the float arm assembly holes and slide the M12 90mm Bolt and tighten the Nylok nut.

**STEP 6:** Repeat steps 2 through 5 for each turnbuckle assembly.

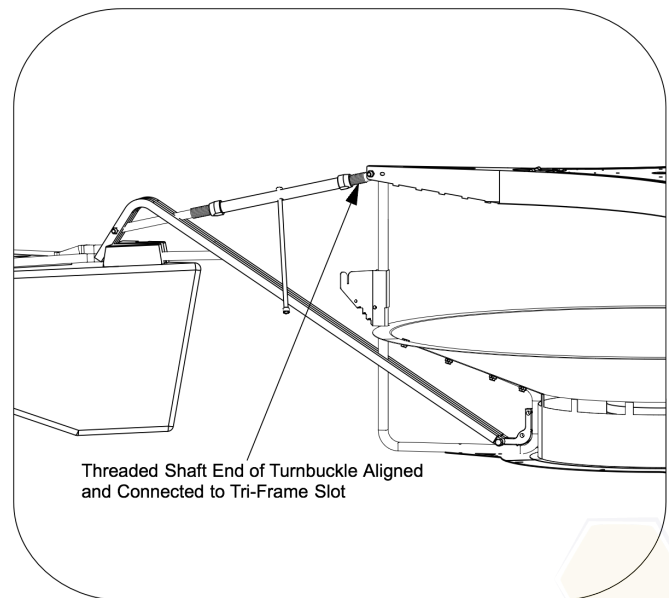
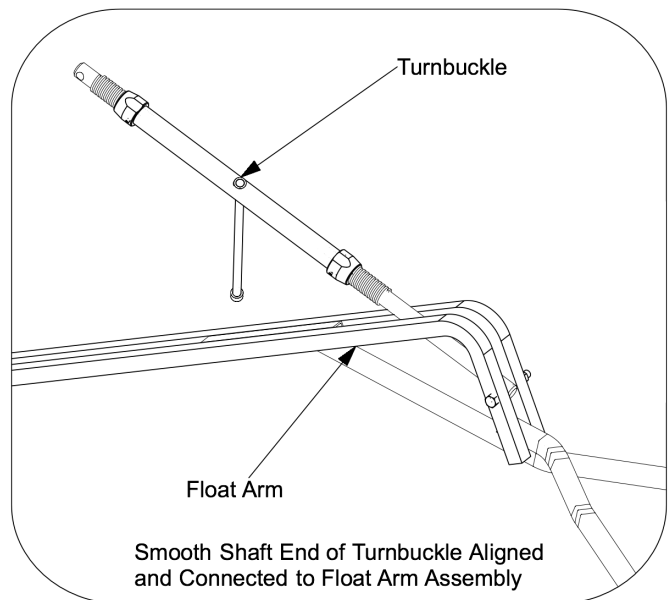
#### FOR DRY INSTALL - Turnbuckle Lengths:

**SB2500:** 33-3/8" Center to Center

**SB5000:** 31-3/8" Center to Center

**SB10000:** 31-1/8" Center to Center

\*The turnbuckles on an **SB1250PW v-12** should be adjusted evenly on both sides so the length of the turnbuckle from shoulder to shoulder is 12-1/2" \*



## Chain Bracket Assembly

### TOOLS REQUIRED:

- (2) 13mm wrench
- 13mm socket wrench (optional)

**STEP 1:** Locate the 3 chain brackets and the M8 X 45mm long bolts and M8 nylok nuts (3 sets needed).

**STEP 2:** Notice that along the perimeter of the dish on the core unit assembly, there are three locations where square tubing extends above the dish. Each of the 3 chain brackets will be attached to each of the three square tubing just above the dish.

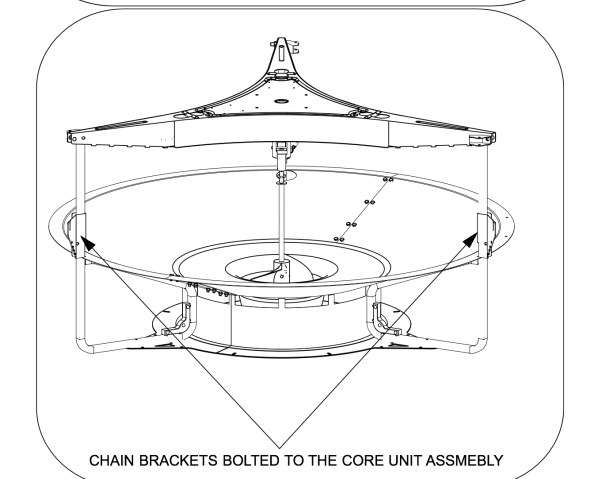
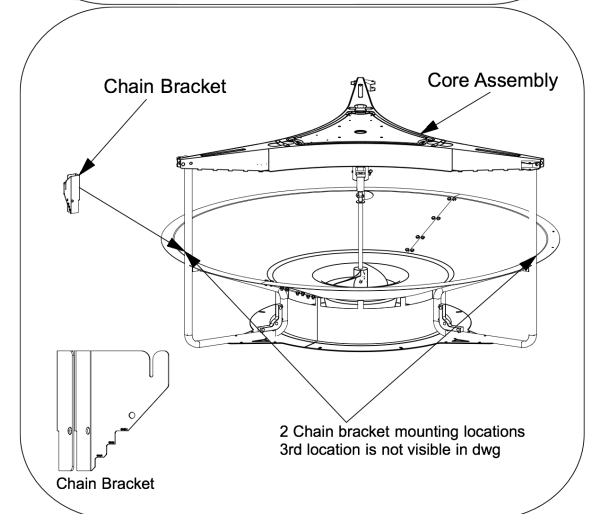
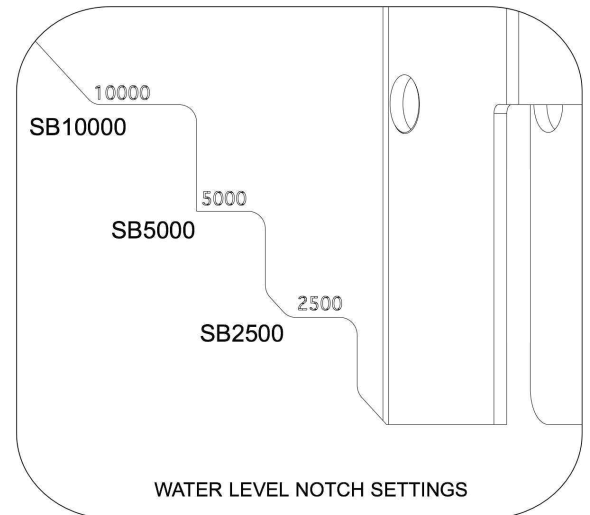
**STEP 3:** Place one of the chain brackets over the square tubing with the wider side facing up and the opening facing outward.

**STEP 4:** Once the chain bracket is slid around the square tubing, insert the M8 x 45mm bolt through the outer holes in the chain bracket. Apply anti-seize to the threads of the bolt. Tighten the M8 nylok nut on the bolt to keep the chain bracket in place using two 13mm wrenches.

**STEP 5:** Repeat steps 3 and 4 for the other 2 chain brackets.



Applying Anti-Seize  
To The Bolts



## Leg Extension Assembly

### NO TOOLS REQUIRED:

**STEP 1:** Tilt or hoist the core unit assembly off the ground. Now the leg extensions can be attached.

**STEP 2:** Slide the leg extension around the three legs of the machine core unit assembly and above the bottom flange ring.

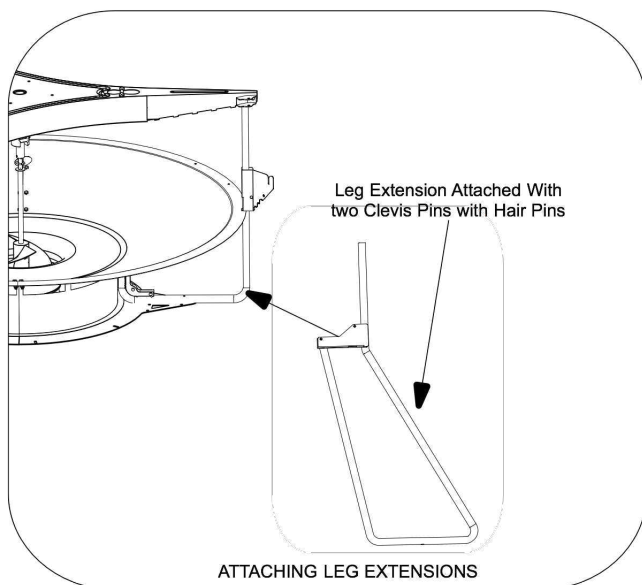
**STEP 3:** Slide the leg extension up snug against the leg to allow two pins to be inserted through the holes of the leg extension.

**STEP 4:** Fasten the leg extension to the machine Core unit assembly using a set of two 5/16 inch x 2 inch (8mm x 51mm) clevis pins.

**STEP 5:** Secure both pins using two hair pins.

**STEP 6:** Repeat steps 2 through 5 for each leg extension.

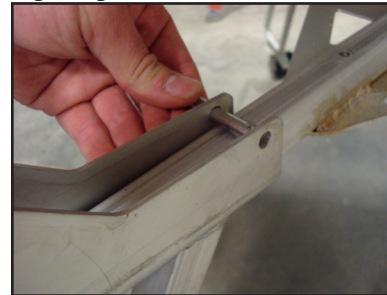
**NOTE:** Once the leg extensions are attached and secure, the leg extensions act as a tri-pod in which the machine can rest on.



Sliding Leg Extension Around Bottom Leg Of Core Unit



Attaching Leg Extension With a Clevis Pin



Securing Clevis Pins



Secured with Hair pins

## Hose Assembly

### TOOLS REQUIRED:

13mm wrench  
13mm socket wrench

**SAFETY NOTE:** When installing the hose, it is very important to have the machine safely suspended by the Leg Extensions, Cribbing, and/or Blocking to prevent a crush hazard.

**STEP 1:** Locate the 36 inch diameter hose with flanges pre-assembled.

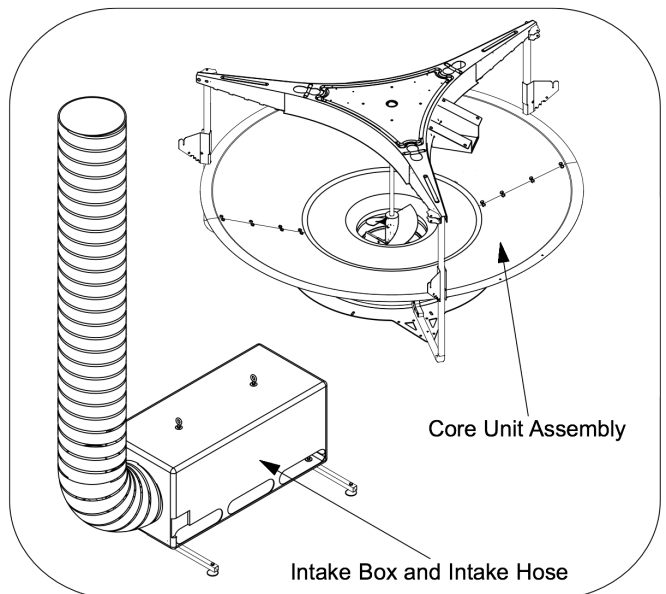
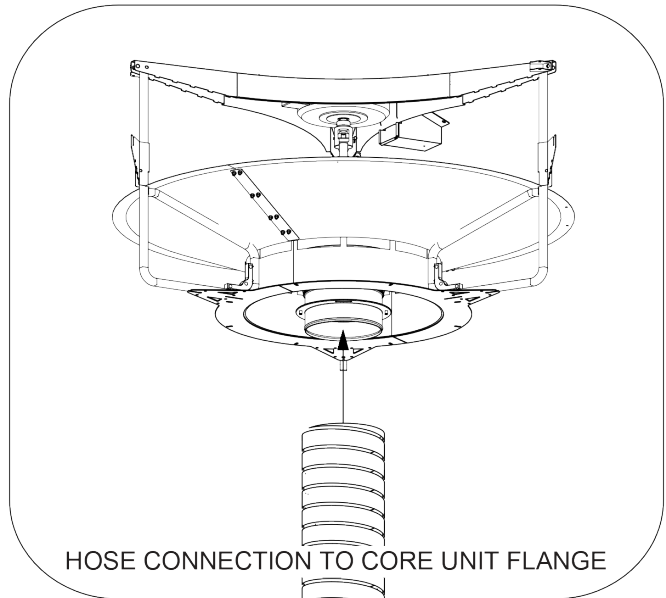
**STEP 2:** Use M8x20 bolts and M8 nylok nuts to attach each the intake plate leg to the bottom hose flange. Use 1 bolt/nut for each strainer leg.

**STEP 3:** Tighten all 4 bolts/nuts using 13mm wrench and socket wrench.

**STEP 4:** With the core unit assembly hoisted or supported on the leg extensions, slide the hose and intake plate assembly beneath the core unit assembly. Line up the upper hose flange slots with the core machine unit flange slots.

**STEP 5:** Use M8x20 bolts and M8 nylok nuts to attach the upper hose flange to the core unit assembly flange.

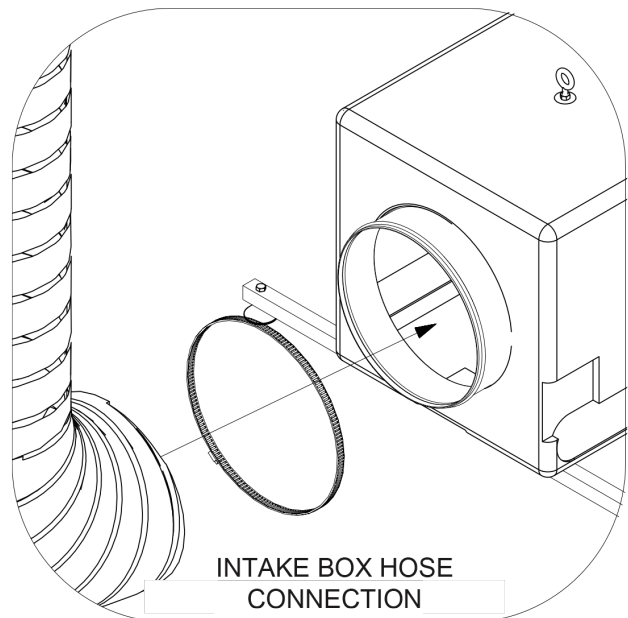
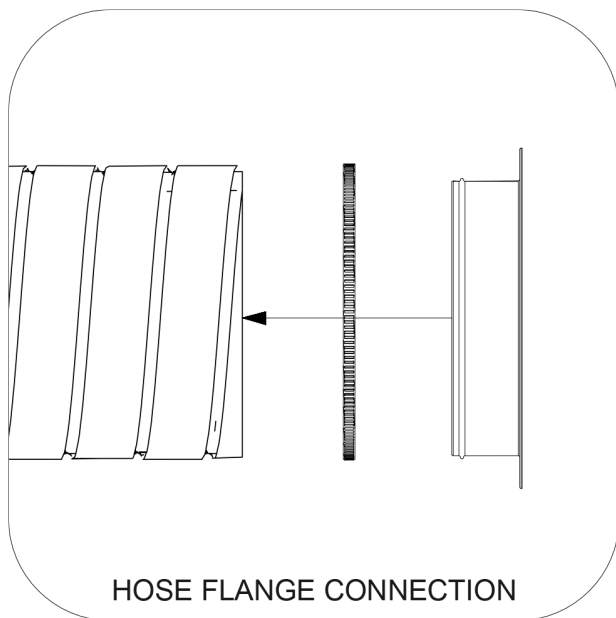
**STEP 6:** Tighten all 8 bolts/nuts using 13mm wrench and socket wrench.



## Hose Intake Assembly

### TOOLS REQUIRED

5/16" Nut Driver for Hose Clamps  
13mm Wrench and Socket Wrench



**STEP 1:** Locate one end of the hose section and place hose clamp over the end, and insert a hose flange. Repeat on opposite end of the hose section. Be sure that hose and clamp are installed above the metal rib of the flange and then tighten hose clamp as tight as possible to firmly secure hose.

**STEP 2:** If multiple sections of hose are required, repeat step 1 for each section of hose. Fasten the hoses together by bolting two flanges using four M8 x 20mm bolts.

**STEP 3:** Fasten one end of the hose assembly to bottom of top frame securing the flange to the top frame using four M8 x 20mm bolts.

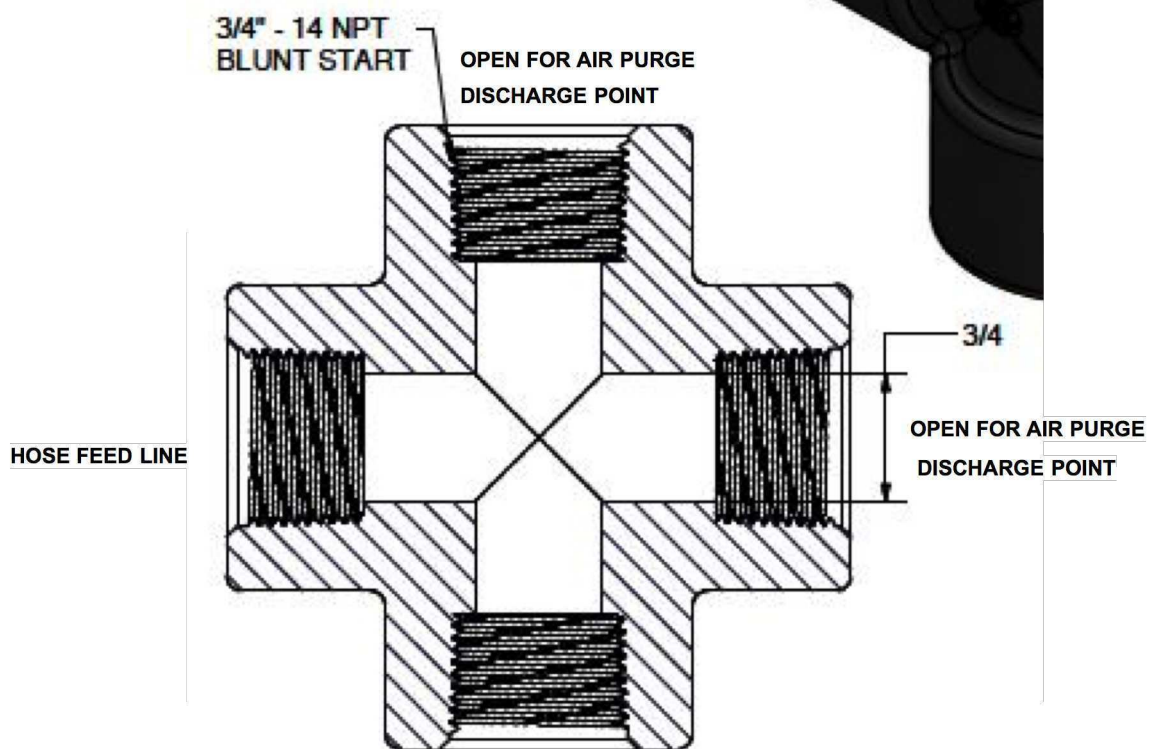
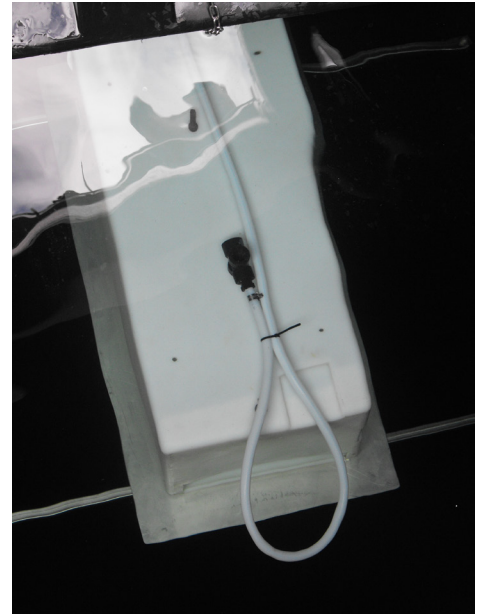
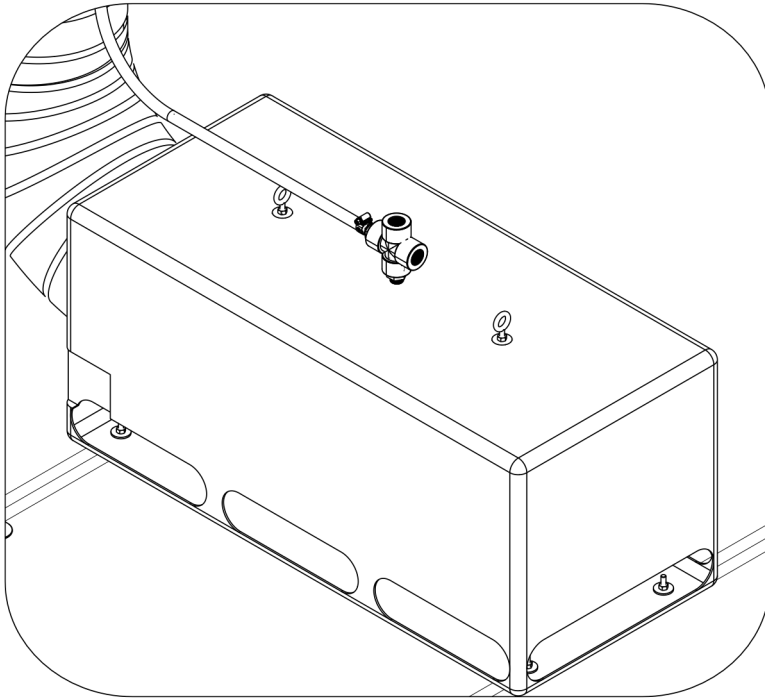
**STEP 4:** Fasten opposite end of the hose assembly to the intake box using four M8 x 20mm bolts.

**STEP 5:** Fasten the two intake box tubings using two M8 x 45mm bolts on each tube.



# Equipment Assembly

## Injection Hose Assembly



## Submersible Cable Interior Assembly

### TOOLS REQUIRED:

5/16" Hand Drive Socket

or

Flat Head Screwdriver

Pliers

**STEP 1:** Locate the submersible electric cable assembly and notice the 4-pin male cordset spliced onto one end. Next locate the Motor Control Cord mounted on the Tri-Frame of the machine with a 4-pin female cordset.

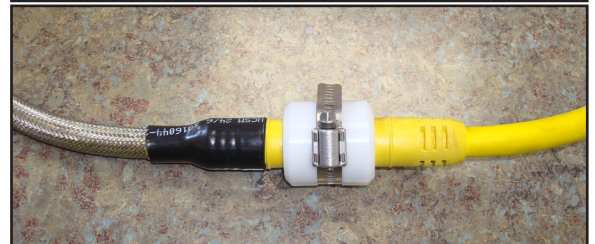
**STEP 2:** Connect the 4-pin male cordset to the 4-pin female cordset by pushing the two ends together.

**STEP 3:** Locate the white cord coupling halves and screw clamp. Place the two cord coupling halves around the black shrouds of both 4-pin cordsets as shown. Firmly press the two halves together.

**STEP 4:** Install the screw clamp around the two coupling halves. Tighten the screw clamp while making sure it is seated in the recessed groove which is centered on both coupling halves

**STEP 5:** Once the connection is made, neatly route the submersible cable along the machine frame, float arm, and float where it will not be in contact with sharp edges or moving components.

**STEP 6:** Using a quick link, connect the kellem grip to the float plate to provide additional cable strain relief in the event that the cord becomes taugt. This will avoid damage to the motor controller and motor.

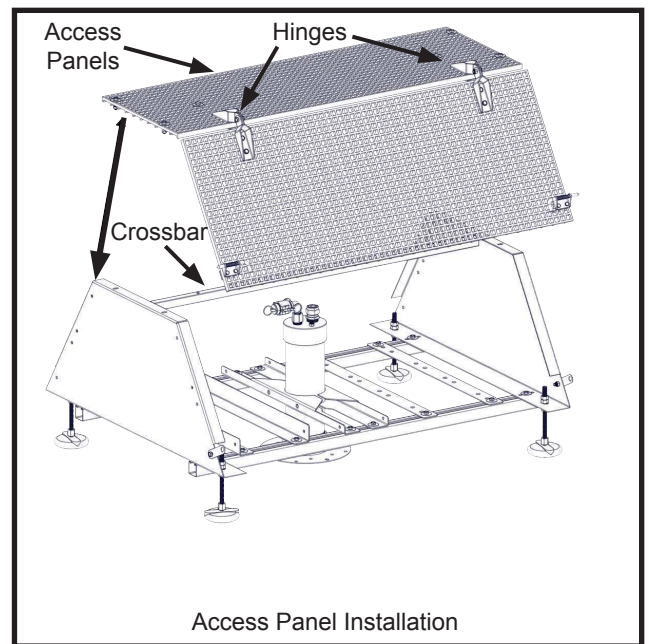
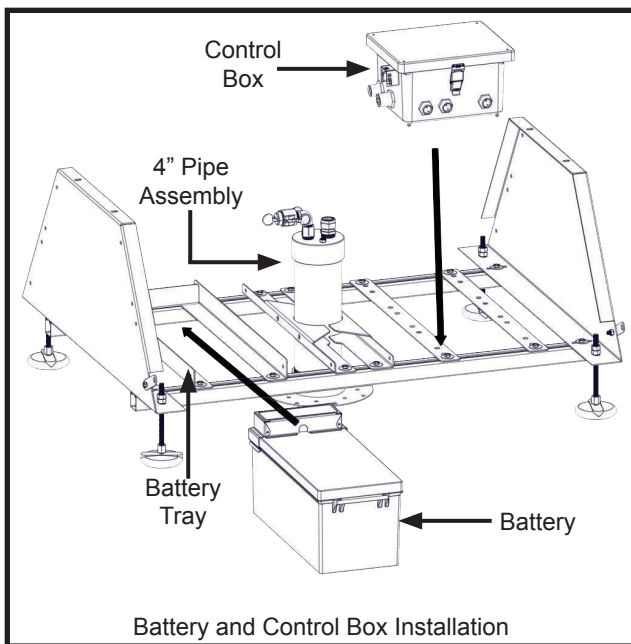
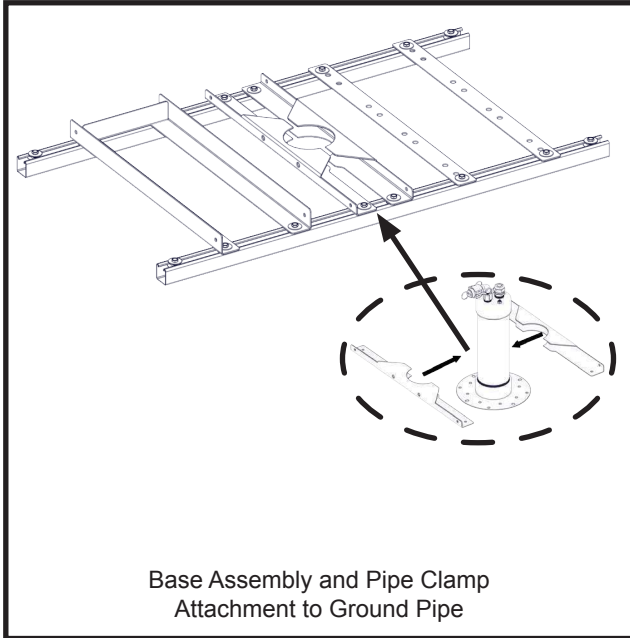


**Kellem Grip  
Connection Point**

# Low Profile Stand

Assembly Diagram

## Low Profile Stand Assembly

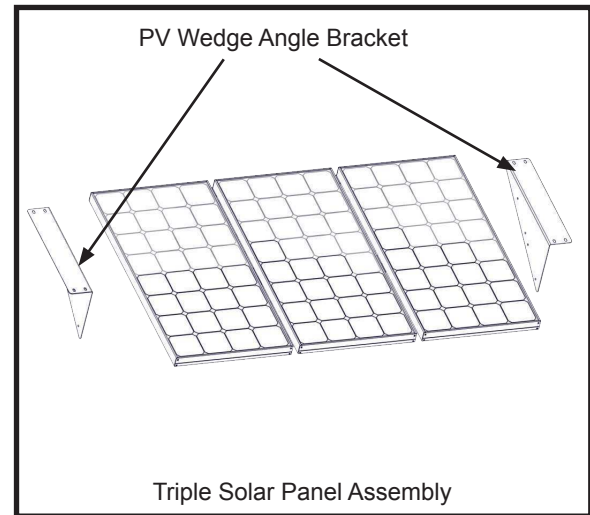
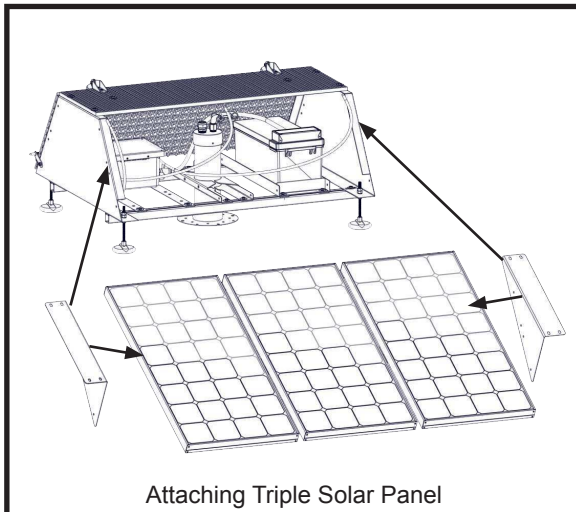
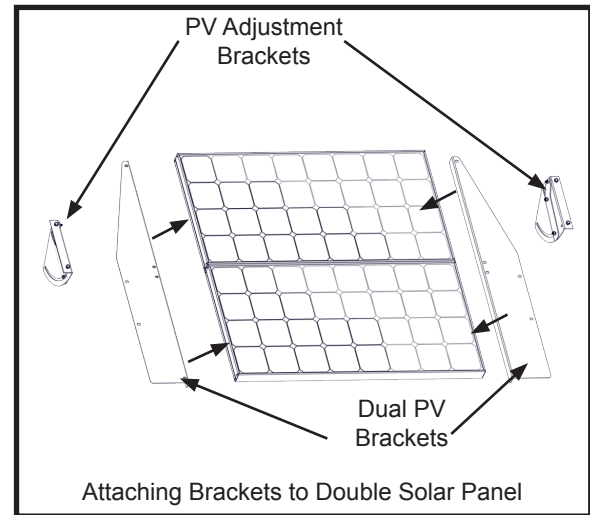
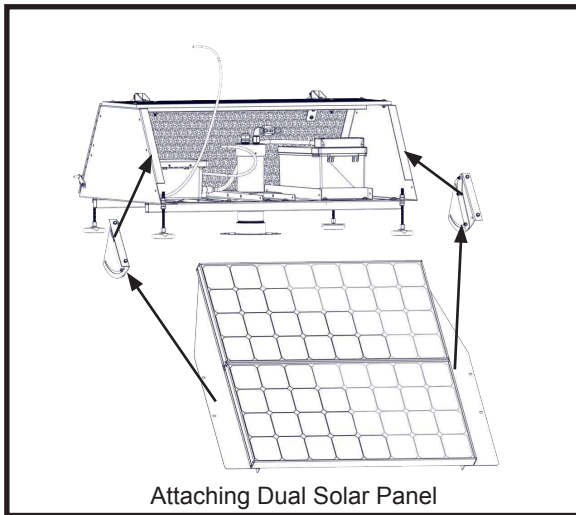
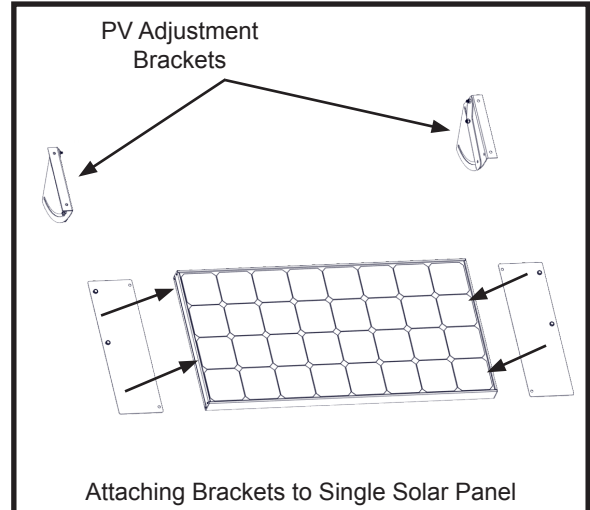
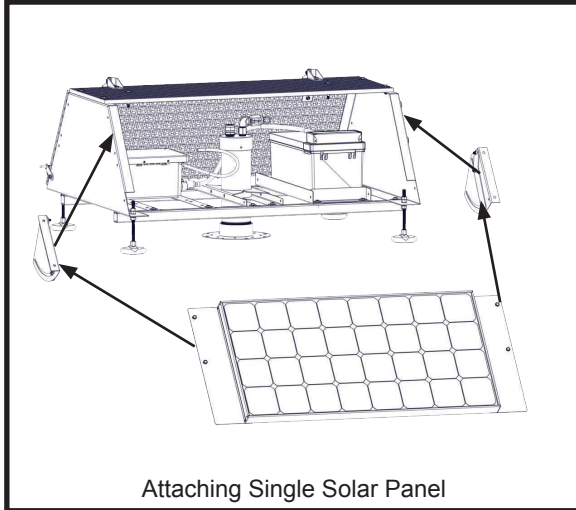




# Low Profile Stand

Assembly Diagram

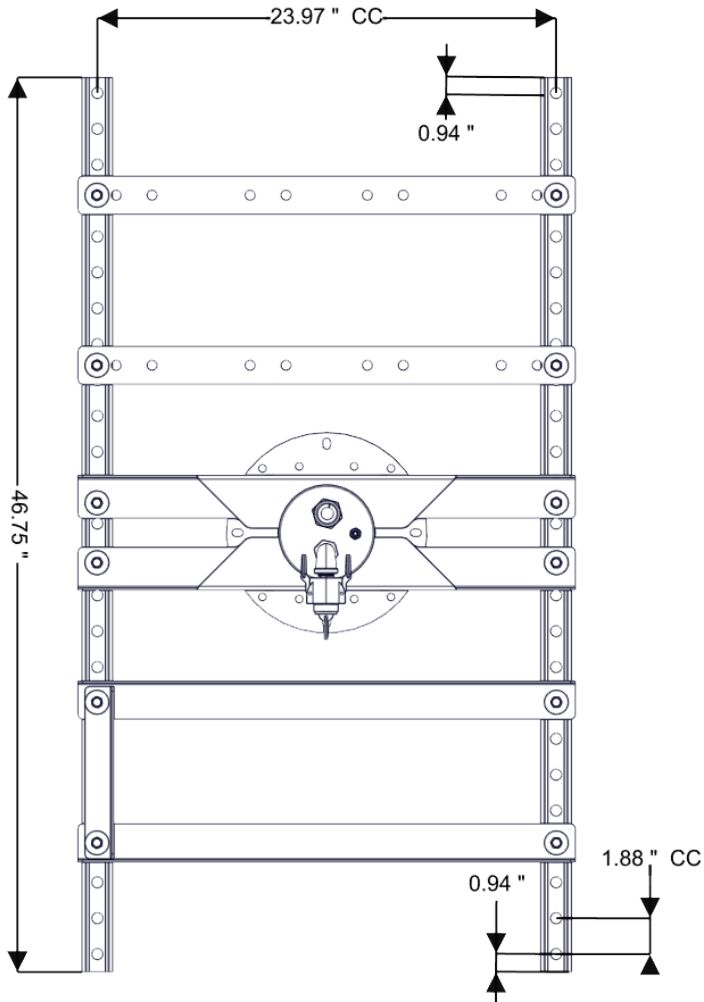
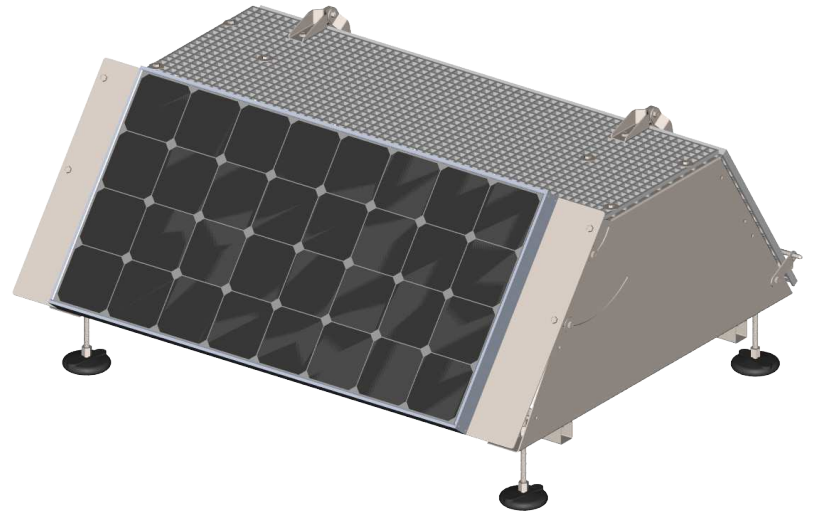
## Low Profile Stand Assembly



# Low Profile Stand

Assembly Diagram

## Low Profile Stand Assembly

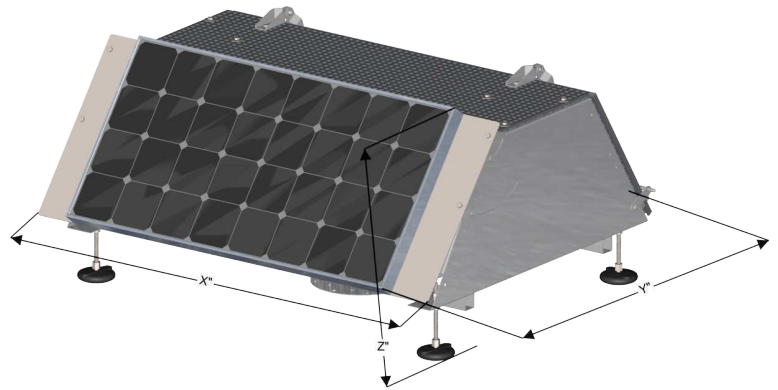
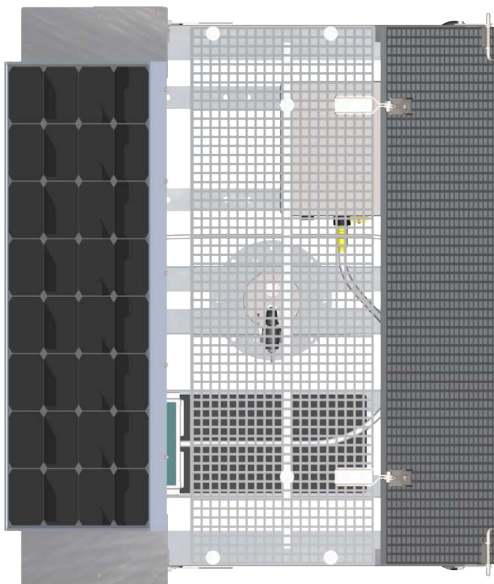


# Low Profile Stand

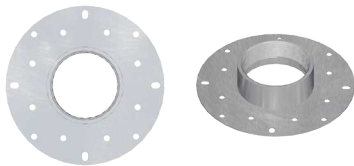
Assembly Diagram

## Low Profile Stand Assembly

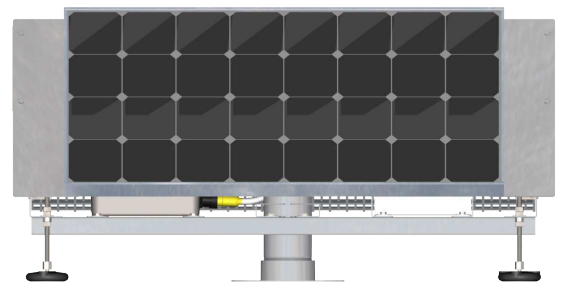
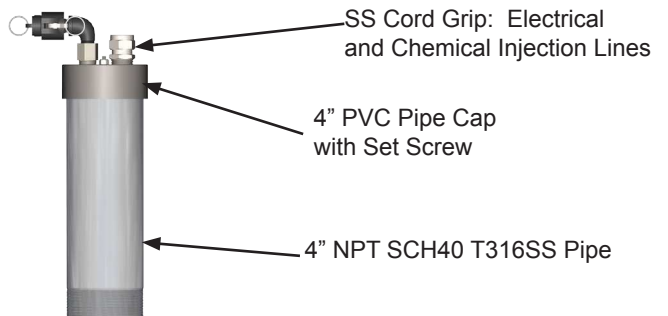
Panel #1	1 Panel	2 Panel	3 Panel
Approximate Weight	290 lbs	300 lbs	310 lbs
X"	52"	52"	63"
Y"	43"	44"	60"
Z"	24"	41"	27"



4 Inch Stainless Coupling Detail



4 Inch Pipe Assembly Detail



# Integration

## 4" Coupling Flange Assembly For Steel Roof Systems

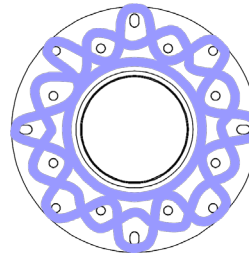
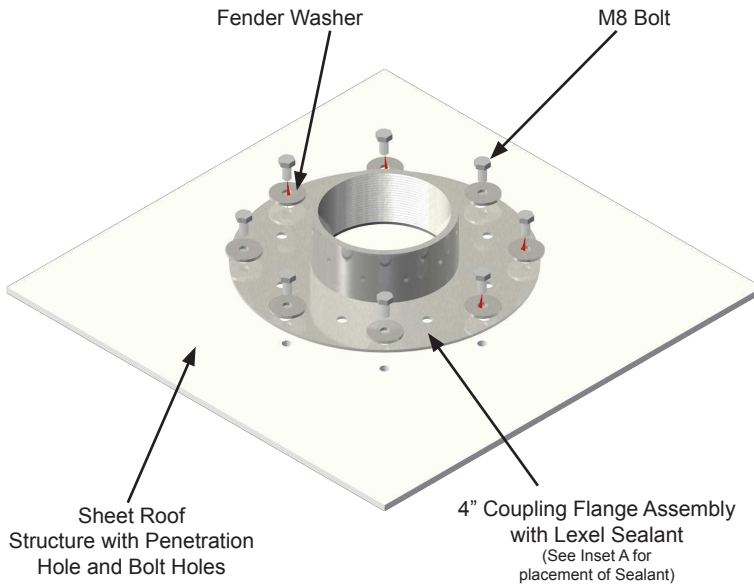


Figure 1: Outside Tank Bolt Installation

**\*\*\* NOT DESIGNED AS A  
SUBMERSIBLE PENETRATION \*\*\***

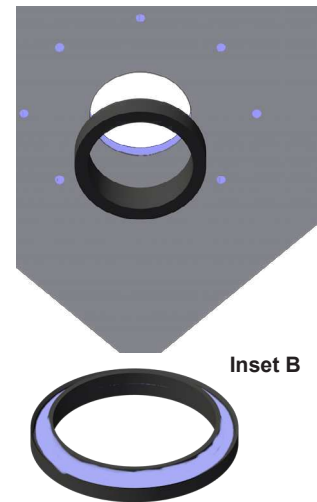
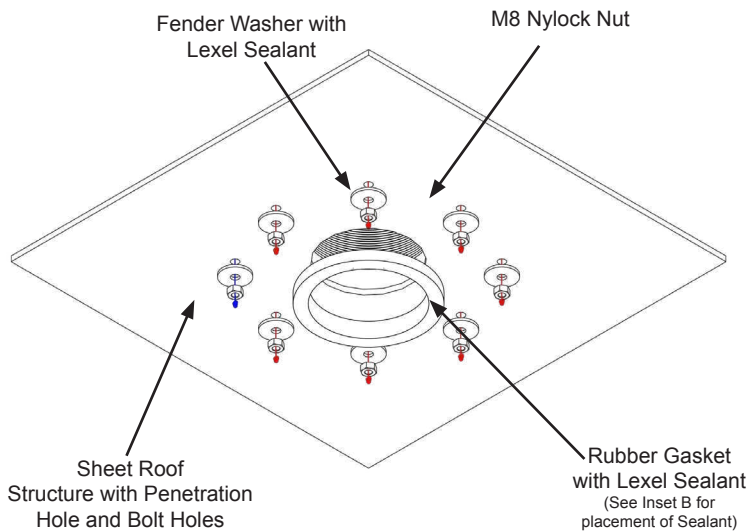


Figure 2: Inside Tank Bolt, Gasket and Flange Installation

## 4" Coupling Flange Assembly

### For Steel Roof Systems

#### T316 SS FLANGE PENETRATION: 4" COUPLING FLANGE ASSEMBLY

TANK PENETRATION IS SEALED WITH  
PVC GASKET ACCOMPANIED BY  
LEXEL® CO-POLYMER RUBBER-BASED SEALANT

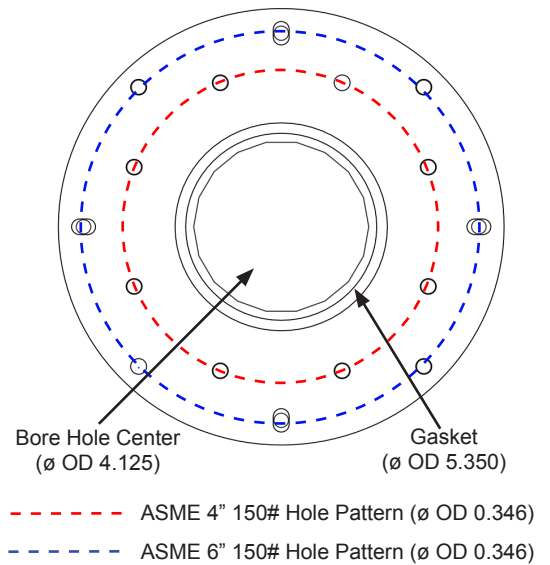
#### 1 FLANGE PER MACHINE:

BOLT PATTERN:	STD 4" 150LB FLANGE STD 6" 150LB FLANGE
GASKET OD:	5.350"
BORE REQUIRED OD:	4.125"
BOLT HOLE OD:	0.346"

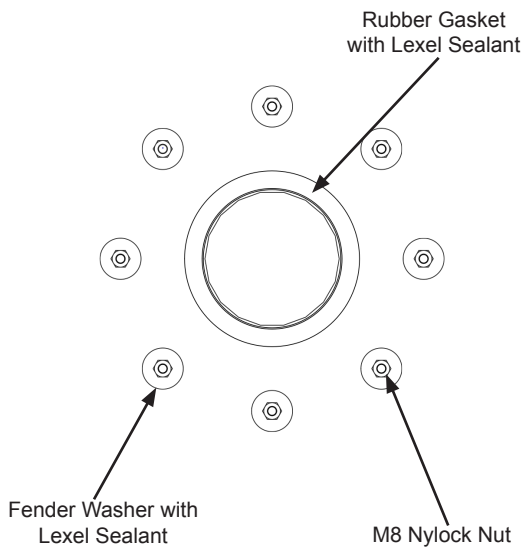
#### Procedural Steps

1. Use Coupling Flange as a template for center hole and at least 6 bolt holes and mark on roof.
2. Make sure to not drill into interior structural beams. Pick a clear location to place the flange.
3. Mark and then cut holes, catch and collect filings.
4. Make sure all holes that have been cut are coated in Lexel sealant.

1 FLANGE PER MACHINE

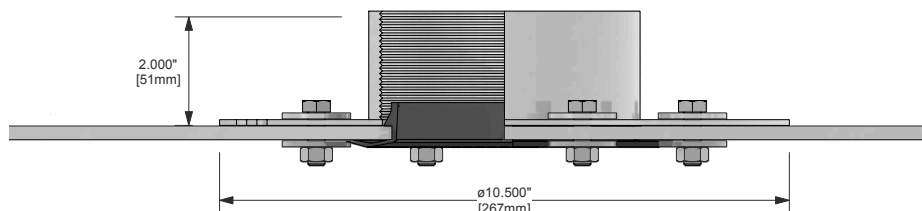


**Figure 3:** Flange Bolt Pattern Outside Tank



**Figure 4:** Bolt View Inside Tank

**Figure 5:** Side Cutaway View of Completed Installation





## Features

# Features

## SB PW Series Mixers

The SolarBee with technology includes new features which enhance its performance through more efficient and durable components, improved operation monitoring capabilities, easy component access, and a robust frame structure.

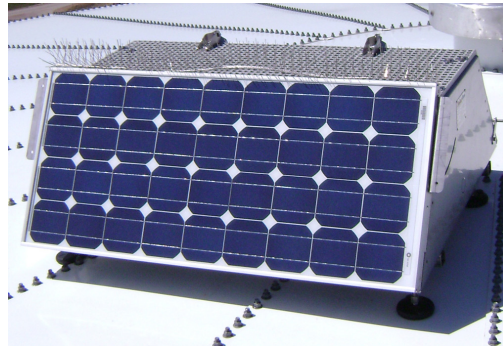
### Solar / Electronics

**Photovoltaic (PV) Modules** -The PV modules are often referred to as the solar panels. The SolarBee uses 100% solar energy to provide day/night operation. The PV modules collect solar power to operate the machine with excess left over to charge an onboard 12-volt, deep cycle battery. The SolarBee has an 80-watt PV modules which individually connect to the digital controller. A bird deterrent is located directly above the PV modules to prevent bird fouling.

The PV module is generally placed on a low profile structure which encloses the controller and battery. The PV module is positioned so it faces the direction of best sunlight.

The low profile solar panel stand offers additional protection by providing shading while also allowing ventilation. Keeping the temperature down inside the digital controller and the battery at a lower temperature which extends the life of the battery and electronics.

**Deep Cycle Battery** - The deep cycle battery stores excess power from the PV module during the day and operates the machine using the stored power during the night and extremely overcast days.



Low Profile Stand  
(1 - 3 Panels)

**MODEL MAY VARY**



Interior of Low Profile Stand

## Features

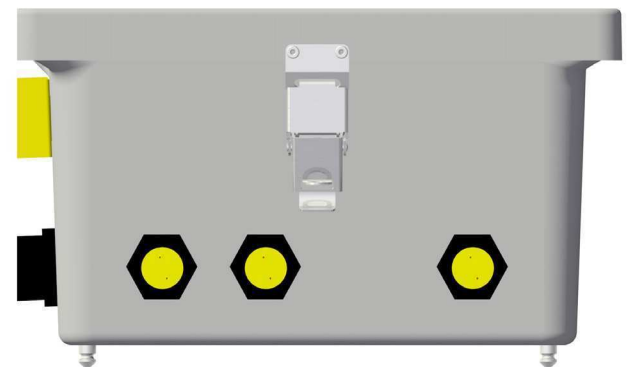
## Features

### SB PW Series Mixers

**Digital Controller** - The digital controller is located inside the the low profile solar panel stand. The digital controller operates and monitors the SolarBee. The digital controller is programmed with application specific run schedule, fallback rpm, and battery charge settings. The SolarBee's Design and Application Engineering groups are constantly reviewing the program to optimize operation. The digital controller can be updated with a new program (firmware) using a SD (Secure Digital) Card, similar to that of a digital camera's memory stick.

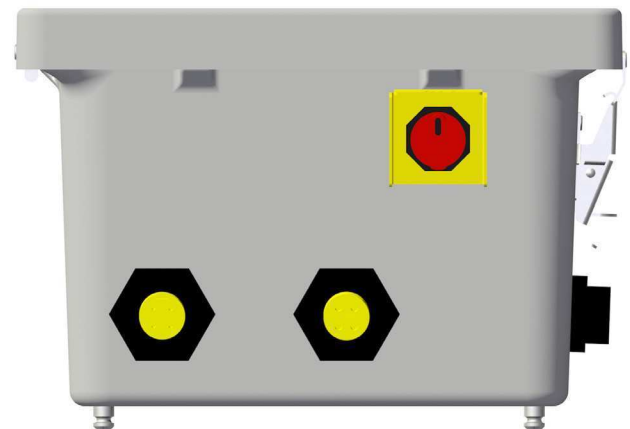


All solar energy collection and motor operation are managed by the digital controller. This component has two primary functions: (1) To direct and divide the power being collected by the PV module(s) between the brushless motor and battery. (2) To serve as the main control center that operates the brushless motor.



Front Face Of Digital Controller

There are 3 PV module connections located on the front face of the digital controller. If the onshore power accessory was purchase, a connection will be located on the right side face. The onshore connection is used only in applications where onshore grid power is desired.



Left Side Face Of Digital Controller

The left side face of the digital controller contains the brushless motor connection, battery connection, and On/Off switch. The On/Off switch activates power to the motor. When the switch is turned to the Off position, the motor will not operate. The charging function of the controller will continue to charge the battery even when the switch is turned off.

SCADA outputs offering machine operation parameters reside within the digital controller. Please contact SolarBee if you are interested in receiving these parameters.

## Maintenance

# Maintenance and Field Adjustment

## SB / GF PW Series Mixers

The performance of the Machine has proven to increase tremendously when its operator understands the operation of the machine and knows how to carry out field adjustment procedures.

In most cases, the operator have can perform routine checkups and field adjustment procedures on the Machine, by pulling the Machine to the hatch. A large, expensive boat isn't necessary. When tank entry is required, an inflatable raft/boat (approximately 6 ft) is deployed inside the tank.

It is extremely important that safety comes first every time the Machine is inspected or having maintenance procedures performed. It is strongly encouraged that anyone working on or near the machine follow these rules:



⚠️ Wear a personal floatation device

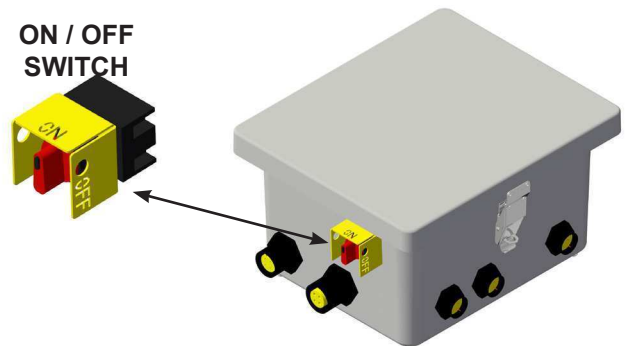
⚠️ Stay focused and alert

⚠️ Turn the Machine off before working on it

⚠️ Stay clear of parts while they are moving

To turn the Machine motor off, turn the On / Off switch to the off position. To completely power down the digital controller, remove all power sources in the proper sequence.

**SAFETY FIRST**



**DIGITAL  
CONTROLLER**



## Maintenance

# Large Frame Rigging Points

## SB/GF Series Large Frame Mixers

When deploying a Machine into the reservoir, it may need to be suspended. If suspending the Machine, it must be suspended from all three rigging points to ensure the support of the weight of the Machine and to keep the Machine balanced once suspended. A crane or hoist is often needed in order to suspend the Machine for deployment into the reservoir.

### TOOLS REQUIRED:

Crane or Hoist (if necessary)

Boat

**STEP 1:** Adjust all three turnbuckles to their full extension. This will raise the entire Machine to its maximum height and aid in towing.

**STEP 2:** Using a three point rigging system, connect to all three rigging points of the Machine. Hoist the Machine by the three rigging points and slowly lower into the reservoir.

**STEP 3:** Tie as much of the hose up as possible. This will reduce some drag when towing the Machine to its position in the reservoir.

**STEP 4:** Towing the Machine can be done one of two ways. The first way is to hook a chain, or towing line, around one of the float arms and pull the Machine with a boat. A second option, and in most cases is the best option, is to push the Machine using the front of the boat.

**IMPORTANT: DO NOT EXCEED 5 MPH (8KM/HR) WHEN TOWING OR PUSHING A MACHINE.**

**STEP 5:** Once in position, lower the hose into the water. If the hose and strainer are not completely submerged, push them both down until the air trapped inside is released. Once the air is released, the hose will lower down into place.

**MODEL MAY VARY**



Rigging Points



**CAUTION: DO NOT REMOVE ANY FLOAT ASSEMBLY PINS OR BOLTS WHILE THE MACHINE IS FLOATING IN THE WATER! THE MACHINE MUST BE RESTING ON THE GROUND OR SAFELY SUPPORTED TO RELIEVE THE FORCES ON THE FLOAT ASSEMBLY STRUCTURES PRIOR TO DISASSEMBLY! FAILURE TO FOLLOW THIS WARNING COULD LEAD TO SINKING THE MACHINE, OR CAUSE SERIOUS INJURY!**

# Maintenance

## Large Frame Dish Levels

### SB / GF Series Large Frame Mixers

#### Distribution Dish Level Setting

The machine distributor dish depth in the water is a key factor in maintaining the near-laminar flow of water coming off the machine.

The distribution dish level setting is measured from the top lip of the dish up to the water surface. For the Large Frame machine, set the depth level according to the following table:

Model	Depth - Inch	Depth - cm
2500	3/4 - 1	2.0 - 2.5
5000	1 - 1 1/2	2.5 - 3.8
7500	2.0 - 2 1/2	5.1 - 6.4
10000	2.0 - 2 1/2	5.1 - 6.4

#### Distribution Dish Level Adjustment

##### TOOLS RECOMMENDED:

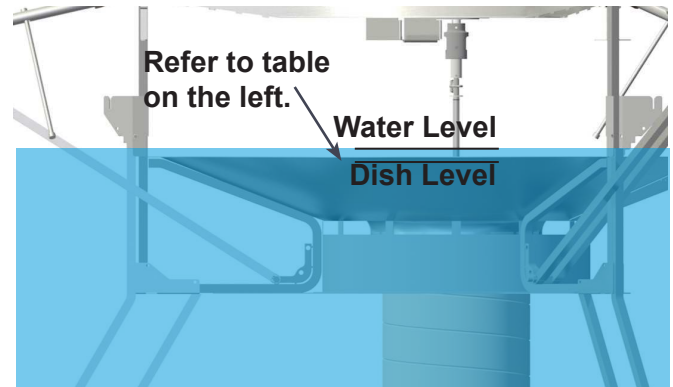
Tape Measure

**STEP 1:** If machine is not on, turn the On/Off switch to the On position.

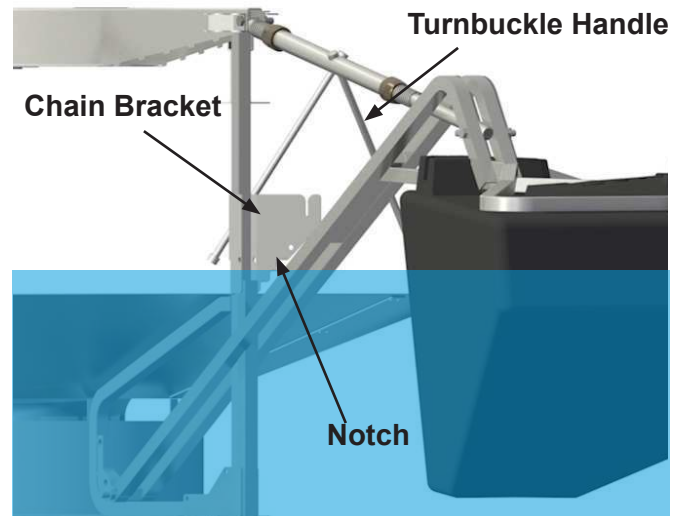
**STEP 2:** Observe if the dish level is too deep or not deep enough at the three locations where each float arm extends out from the machine. This can be done using a tape measure, by approximating the height of a nickel, or locating the notch on each chain bracket for machines having a hose. If using the notch on each chain bracket, the water level should be even with the appropriate notch (see picture).

**STEP 3:** Set the dish to the correct level in each of the three locations. To raise the dish level, rotate the turnbuckle around (clockwise) so that it is expanding. To lower the dish level, rotate the turnbuckle around (counter-clockwise) so that it is compressing.

**STEP 4:** Double check dish level at all three locations and fine tune as necessary.

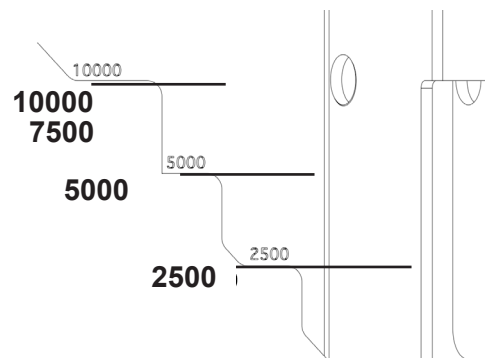


Distance Between Distributor Dish And Water Level



Water Level Even With Notch On Chain Bracket

#### WATER LEVEL NOTCH SETTING FOR:



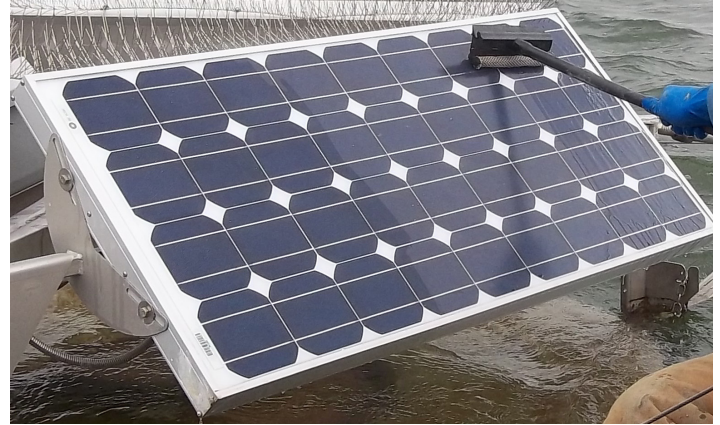
Dish Depths For Different Models of machines

## Maintenance

# PV Module Cleaning

## SB Series Mixers

The solar panels are the SolarBee's primary source of energy, so it is important that they be kept clean. Over time, dust collects on the PV modules or birds are not kept completely off by the bird deterrent resulting in the panel's effective surface area decreasing.



### (If Equipped the following applies)

The SolarBee controller and solar panel(s) are generally located on the roof of the tank or reservoir. If your tank is ground storage standpipe, hydropillar, pedesphere, or other style elevated tank, please follow the necessary OSHA regulations in regards to Fall Protection, Rescue, etc.



### TOOLS RECOMMENDED:

Squeegee  
Glass Cleaner  
Paper Towel or Wash Cloth

**STEP 1:** Rinse panel face off with water.

**STEP 2:** Use squeegee, towel, or wash cloth to clean surface of panel.

**STEP 3:** Remove any streaks or films using glass cleaner and paper towel/wash cloth.

**STEP 4:** Repeat Steps 1 through 3 for each solar panel.



# Maintenance

## RPM Check

### SB/GF Series

#### Impeller Rotational Speed Check

During clear skies and good sunlight weather conditions, the drive system of the unit should operate:

- 1) At a rotational speed between 55 and 85 revolutions per minute (rpm).
- 2) In a clockwise direction when looking down at the impeller.

#### Checking Rotational Speed

##### TOOLS RECOMMENDED:

Watch or Stopwatch

**STEP 1:** Locate the flag indicator on the impeller shaft.

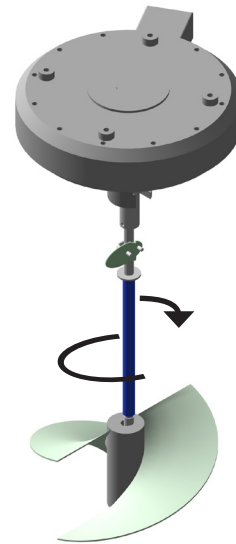
**STEP 2:** Start the stopwatch or mark a starting point on the watch. Immediately begin counting each full revolution of the flag indicator (starting with "ZERO", "ONE", "TWO", etc) for a time of less than or equal to 1 minute and at least 20 seconds. This step is easier with two people, one counting revolutions and the other keeping track of the time expired.

**STEP 3:** Quit counting revolutions and immediately observe how much time has expired in seconds.

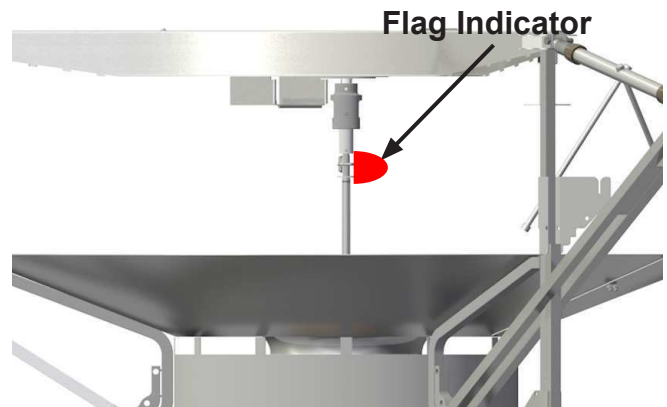
**STEP 4:** Use the following equation to calculate rotational speed in rpms:

$$\text{Revolutions Per Minute (RPM)} = \frac{(\# \text{ Revolutions Counted} \times 60)}{\# \text{ Seconds Expired}}$$

MODEL MAY VARY



Clockwise Rotation When Looking Down



Flag Indicator Section of Impeller Shaft

Example: 30 Revolutions were counted in a time period of 30 seconds.

$$\text{RPM} = (30 \text{ revolutions} \times 60) / (30 \text{ seconds}) = 60$$

Impeller Rotational Speed = 60 RPMs



# Maintenance

## Battery Replacement

### SB Series Potable Water

#### Battery Replacement

The SolarBee contains an onboard battery located in the electronic controller that will require infrequent replacement. Between 2 and 3 replacements are expected over the course of the machine life.

#### TOOLS RECOMMENDED:

NO TOOLS REQUIRED:

**STEP 1:** Open the solar panel stand access panel located opposite side of the solar panel.

**STEP 2:** Locate the electronic controller and the On/Off switch. Turn the switch to the "OFF" position.

**STEP 3:** Refer to proper Power Down Procedure located in the Electrical Section.

**STEP 4:** With the SolarBee off, unscrew the battery lead from the battery terminal.

**STEP 5:** Slide the battery out of the panel stand box.

**IMPORTANT NOTE:**  
**The battery weighs approximately 140 lbs and may require two people to handle.**

**STEP 5:** Install new battery into position and connect battery lead back up to the battery terminal.

**STEP 6:** Refer to the proper Power Up Procedure located in the Electrical Section.

**STEP 7:** Turn the On/Off switch back to the "ON" position.

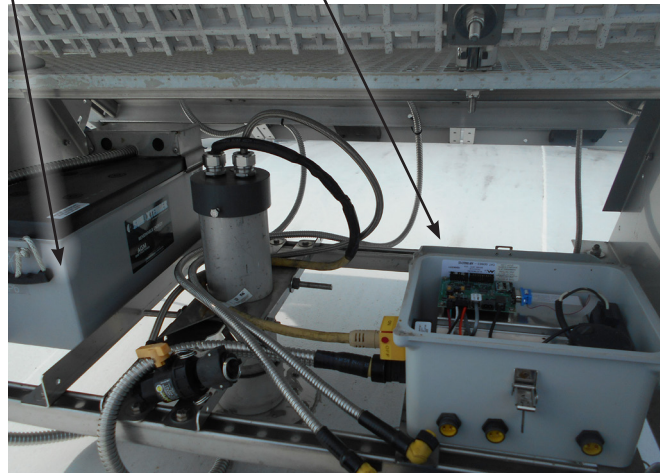
**STEP 8:** Be sure the SolarBee is operating correctly and close the access panel.

**\*\* Failure to follow these steps could result in component damage. \*\***



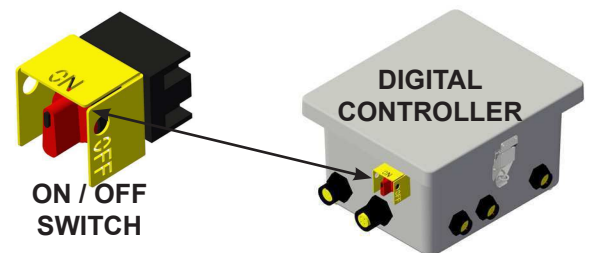
Battery

Electronic Controller



Solar Panel Stand Open With  
Controller And Battery

**Battery Disposal: Be sure to follow local law and regulations when disposing of the used up battery!**



## Maintenance

# Tank Maintenance

## SB / GF Series Mixers, Potable Water

### Tank Maintenance

The machine is designed to rest on the floor of the tank in an event when the tank is drained. If the machine is left undisturbed, the machine will naturally float and self adjust when the tank is refilled.

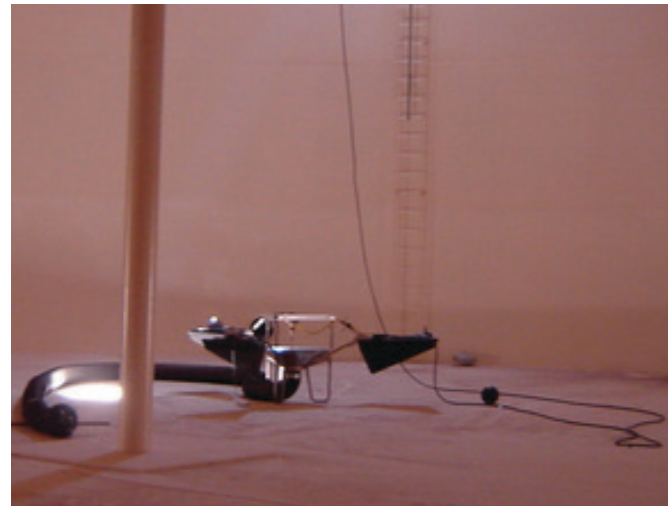
During the event that a potable water tank is taken off-line for maintenance for re-coating, sandblasting, or cleaning, a few considerations need to be followed for the care of the machine. The best solution for the care of the machine is to remove the unit from the tank until the maintenance is complete. Often times there is an access hatch thru the side of a tank which the machine in most cases can easily be removed. Sometimes this is not an option and the following guidelines should be followed in the event of interior tank work.

**STEP 1:** Turn the machine circulation equipment "Off" if the tank is projected to be dry for more than a few days. The On/Off switch is located in the machine electronic controller mounted to the pv module stand.

**STEP 2:** Cover the entire machine, including the hose and intake assembly, using a heavy duty tarp. Be sure to tuck the tarp under the machine to avoid any sand being collected on the machine in the case of sandblasting.

**STEP 3:** The electrical cord and chemical injection cord will be suspended from the ceiling so extreme care needs to be taken to prevent damage to the cord and hose from any abrasions from blasting. Both injection and electrical may be disconnected and coiled up under the tarp if desired.

**STEP 4:** Once the maintenance is complete, remove the tarp and reconnect the electrical cord and chemical injection hose (if applicable). The machine may need to be cleaned from any dust or sand that may have made it's way thru the tarp. A key component that should be checked and cleaned is the impeller bushing and impeller tip. Please follow the proper procedure earlier in this section.



Machine power cord laying tangle free.



Machine resting on floor ready for water.

## Maintenance

# Tank Maintenance

SB / GF Series Mixers, Potable Water

### Tank Maintenance continued,

**STEP 5:** Decontaminate the machine by wiping all machine surfaces using a bleach/water solution and a towel or cloth. Remove all excess dust, sand, etc. **Do not use a pressure washer to clean the machine.** This may damage the on-board electronics which may result in improper operation of the machine.

**STEP 6:** The machine intake needs to be placed in its original position and the entire hose layed out across the floor. *The hose should not be coiled or draped over the machine!* Reposition the electrical cord and injection hose so they do not get tangled on any objects.

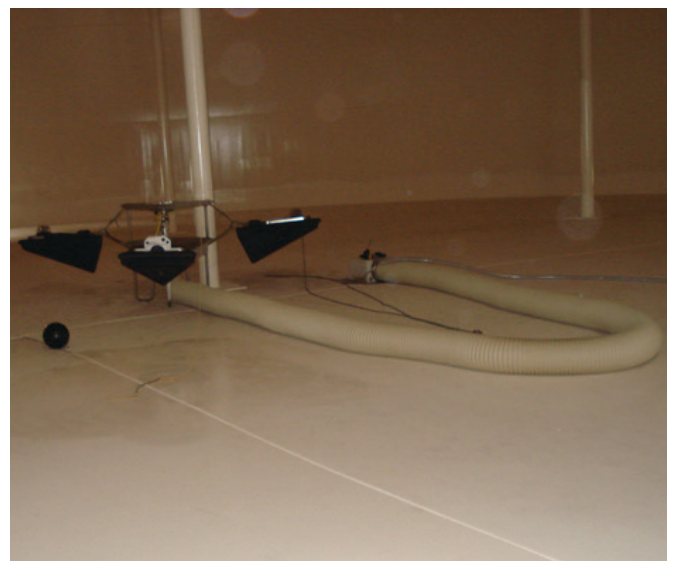
**STEP 7:** The machine is now ready for the tank to be filled with water and be turned "On".

Most customers feel that removing the machine circulation equipment is the best option for the safety of the equipment. Removing the equipment also allows for the contractors to perform their work freely and not have to maneuver around the machine.

**Please contact Ixom Customer Service:**  
**1-866-437-8076 (customerservice@ixom.com), for a quote for temporary removal of your machine.**



Machine resting in drained tank.

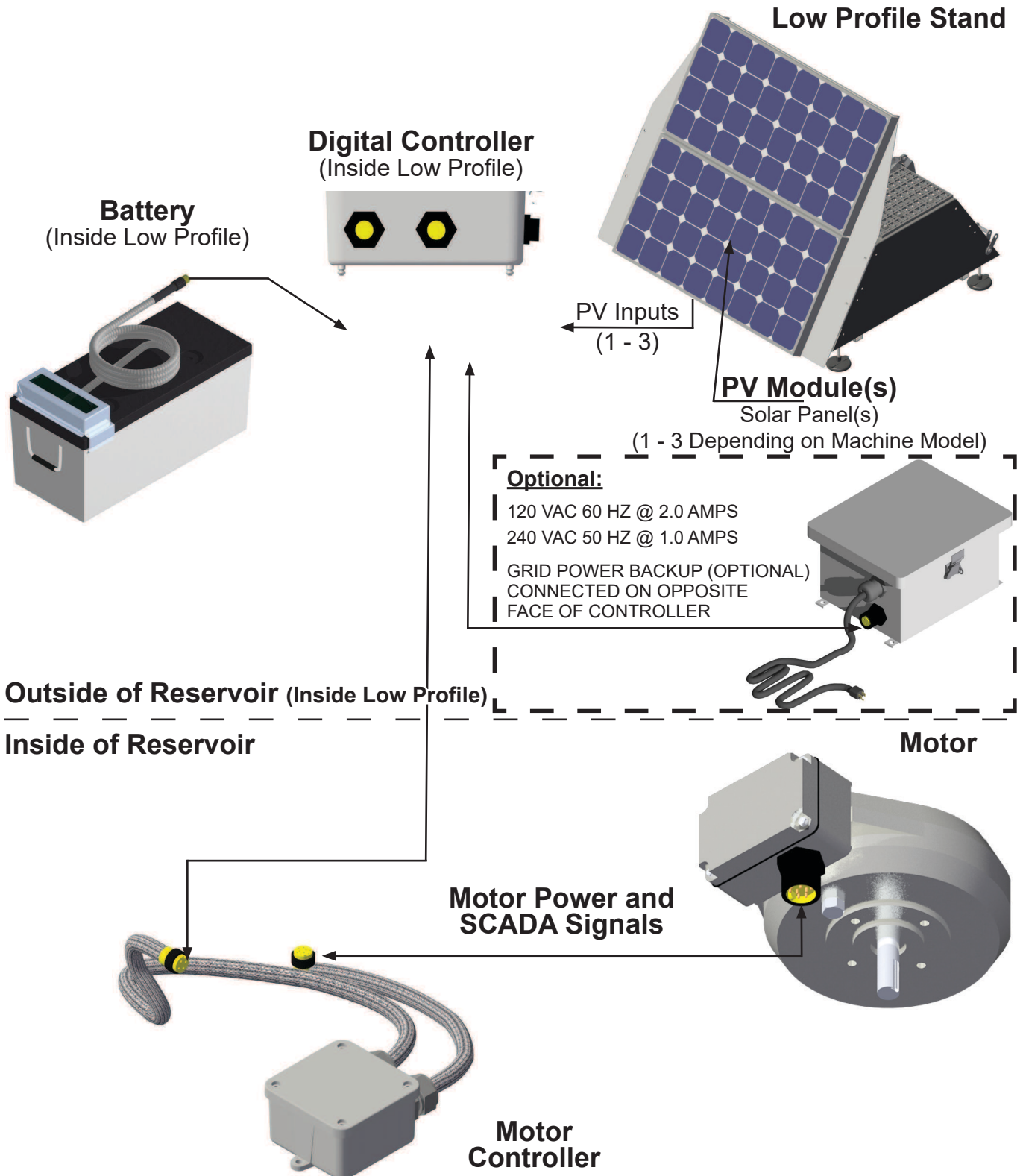


Hose properly layed out on tank floor.



# General Electric Overview for Potable Water SolarBee







(Low Profile)





# SolarBee/GridBee SD Card

## Update Instructions

Insert the SD card into the slot. The solid blue light beside the slot will come on.	 SD CARD INSERTED
Once the correct files have been found, the green light will begin to flash rapidly.	 FILE SEARCH AND DOWNLOAD
When it is time to remove the card, the green and yellow lights will flash rapidly and be alternating. <b>Remove the SD card from the slot.</b>	 DOWNLOAD COMPLETE REMOVE SD CARD
When the card is removed, the red light will flash rapidly. This is the beginning of the self programming with instructions received from the SD card. After the red light is finished, the yellow light will flash rapidly, followed by the green light.	 INITIALIZING PROGRAM
Upon completion the brainboard will restart and perform a system check. <b>Following a successful update</b> the red light blinking once followed by one yellow blink and one green. If you miss this or are unsure, you can repeat the previous steps	 SD CARD UPDATE SUCCESSFUL
If the update was not successful, the red, yellow, and green lights will blink together 10 times. The machine will revert to the default parameters. Insert the card to attempt the update again. If it still fails, contact Customer Service.	 UNSUCCESSFUL SD CARD UPDATE

*Please refer to the provided owners manual for normal operation led blink codes.*

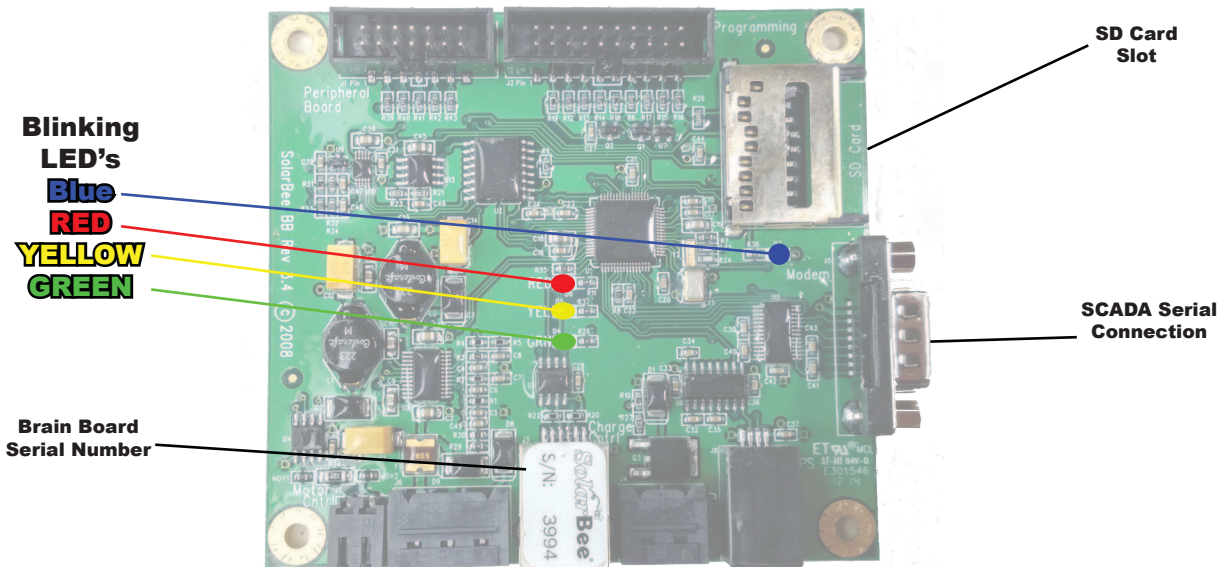


Figure 1: Brainboard

# Electrical

## Power Down / Power Up Procedure

### SB Series

#### Complete Power Down Procedure

NO TOOLS REQUIRED:

**STEP 1:** Turn the On/Off switch to Off position.

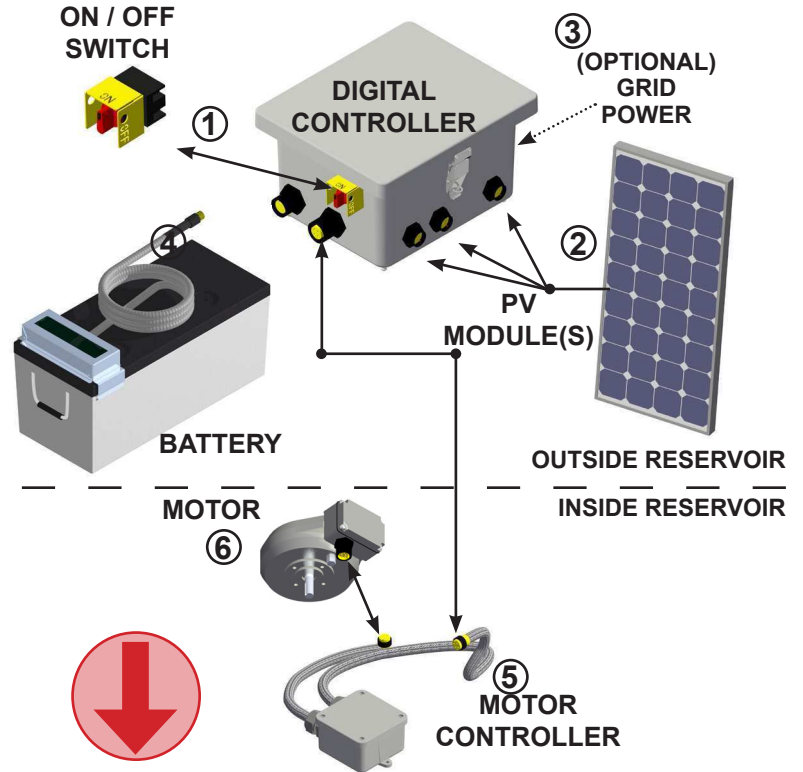
**STEP 2:** Unscrew all PV module leads on the front side of the digital controller.

**STEP 3:** Unscrew the on-shore (grid power) connection on the right face, if applicable.

**STEP 4:** Disconnect the battery lead on the left face. Now all power is taken away from the electrical system.

*Be certain steps 1-4 have been completed before continuing. If this order is not followed, component damage may occur.*

**STEP 5 & 6:** Disconnect the motor controller from the digital controller and from the motor if needed.



#### Complete Power Up Procedure

NO TOOLS REQUIRED:

**STEP 1 & 2:** Connect the motor controller to the motor and to the digital controller.

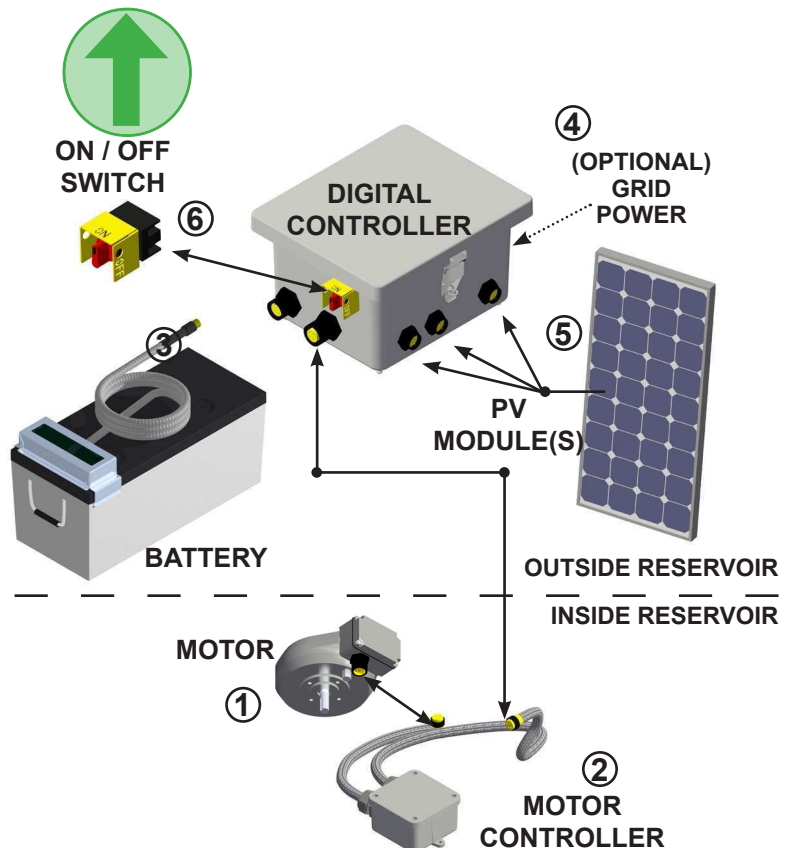
*Be certain steps 1-2 have been completed before continuing. If this order is not followed, component damage may occur.*

**STEP 3:** Now you are able to bring power to boot up the system by plugging in the 4P Male connector of the battery to the left face of the digital controller.

**STEP 4:** If applicable, connect the on-shore (grid power) 2P male connection to the right side of the digital controller.

**STEP 5:** Connect all available PV module leads into the front face of the digital controller.

**STEP 6:** Turn the On/Off switch to On position.



# Troubleshooting

## Troubleshooting

### SB Series

If you find that the SolarBee has quit operating, the following checks can be performed:

#### Connection Check -

- 1) Locate the digital controller and be sure that each PV module cord is properly connected.
- 2) Check that the battery is properly connected.
- 3) Follow each cord from the electronic controller to its originating component and be sure it is not damaged.

**Visual Digital Controller Check -** The SolarBee contains an LED (Light Emitting Diode) blink sequence that indicates the machine operation status. The blinking LEDs are found on the Brain-board located inside the digital controller. A solid green LED is also located on the Zahn board. To observe the LEDs,

- 1) Open the door of the digital controller and locate the laminated LED label on the inside of the door.
- 2) Using the LED label, locate the Brain-board and the Zahn board. Observe and record the blinking LEDs (color and # of blinks in succession) and solid green LED (off or on).
- 3) Using the LED label, match your blink observations to the corresponding indication. Use the information on the next two pages to proceed.

#### DC Voltage Check -

If a DC voltmeter is available, the battery voltage can be measured off of the brainboard at the 3-pin connection (white, black, and orange leads).

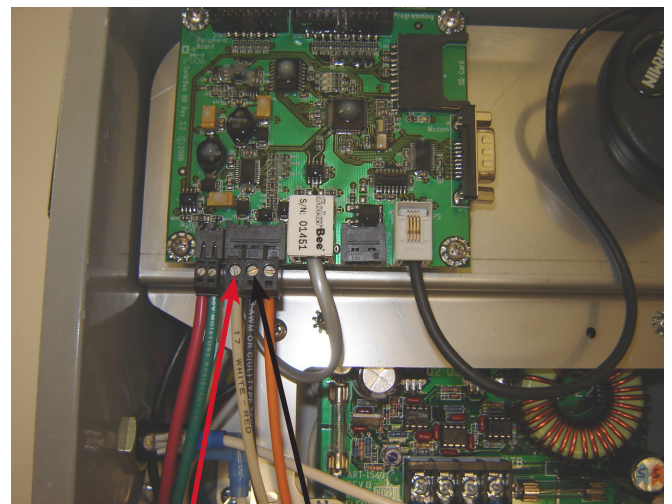
- 1) Using the voltmeter positive lead on the white screw terminal and voltmeter negative lead on the black screw terminal, the voltage can be measured.
- 2) Record the measurement.

**SCADA Information -** SolarBee operation status information can be transmitted from the machine to a nearby monitoring station by using one of SolarBee's various SCADA kits. Contact Ixom Watercare, Inc. Customer Service for more information.

**Ixom Watercare, Inc. is committed to serving our customers. Feel free to contact a SolarBee Customer Service Representative if you experience any problems with your SolarBee. At SolarBee, we will get you technical support, parts, or a service visit to make sure that your SolarBee is back online in short time. (866) 437-8076 or customerservice@ixom.com**



SolarBee Installation / Service Crew



12 VDC+

12 VDC-



# Troubleshooting

## Troubleshooting

### SB Series

#### Blink Indication Follow-up Procedures

Blinking Green - System healthy, machine should be operating on programmed run schedule. If not operating on programmed run schedule, contact SolarBee Customer Service.

1X Blinking Yellow - High motor current, check the machine for plugging at impeller and/or strainer-intake.

2X Blinking Yellow - Low battery voltage, machine may be operating at reduced speed or temporarily shut down due to cloudy weather period. Re-check machine after sunlight conditions improve.

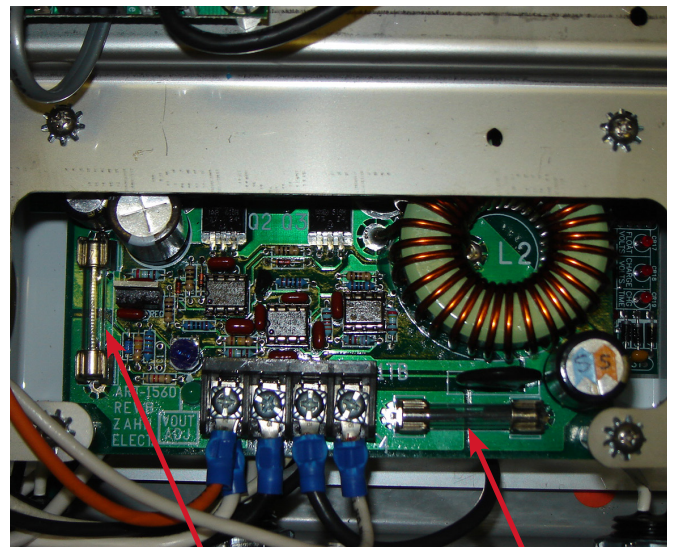
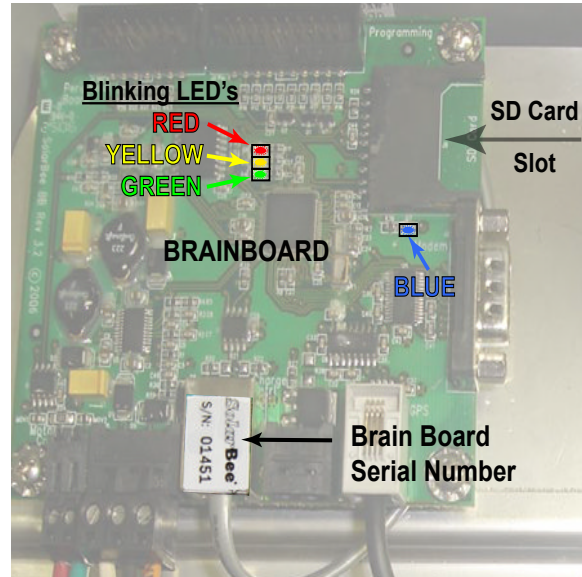
5X Blinking Yellow - Check GPS connection at Brain-Board (lower right corner). If properly connected and blink code persists, contact SolarBee Customer Service.

1X Blinking Red - Anti-Jam Routine, machine is operating on a jam removal sequence triggered by high current. Check for plugging only after disconnecting power. If power is not removed first, machine may begin to operate

2X Blinking Red - 36 VDC out of range, machine may be shut down due to blown fuse (glass cylindrical) on the Zahn Board. Left side of Zahn board takes a 5 Amp Fuse, Right side of Zahn board takes a 20 Amp Fuse. Disconnect power before changing fuses. Blown fuses may be difficult to observe, so a continuity tester or new fuse should be used to confirm that the problem is not a blown fuse. If your SolarBee has a fuse switch (20 Amp), check that fuse also.

5X Blinking Red - Battery out of range, machine battery is too low. Check and record battery voltage if possible, then contact SolarBee Customer Service.

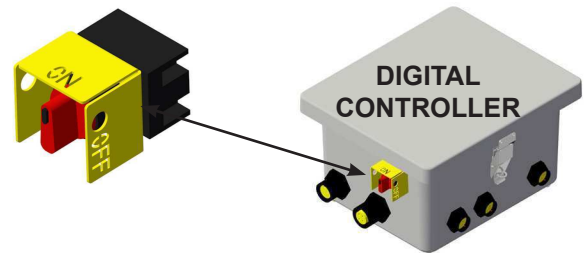
For all other blink codes, please contact SolarBee Customer Service.



5 Amp Fuse

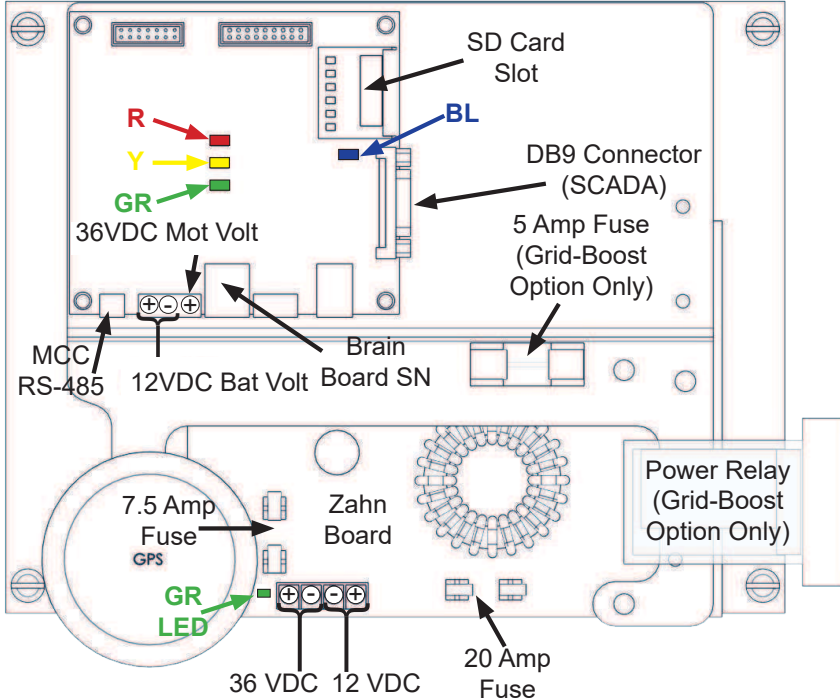
20 Amp Fuse

ON / OFF SWITCH



## SB Series Status Codes

### SB Series: Control Box Lid Label

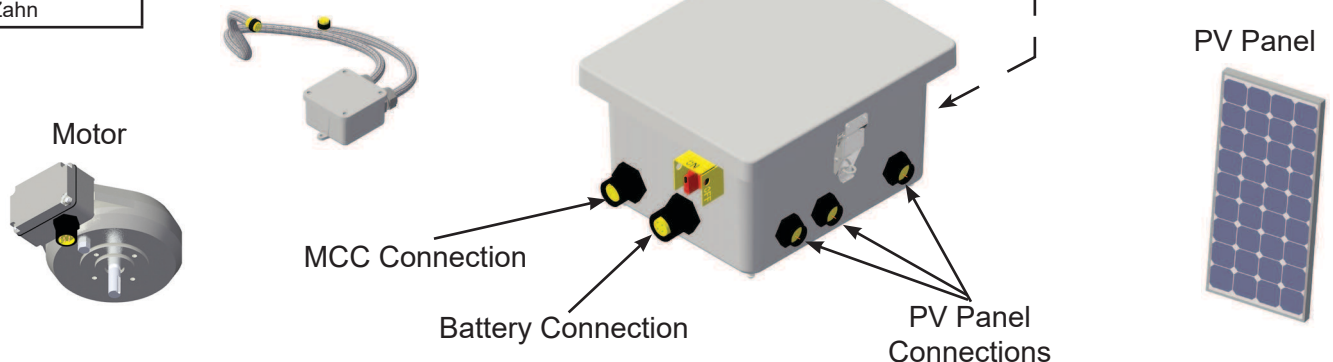


BEHAVIOR	VISUAL	INDICATION
BLINK GR		HEALTHY SYSTEM
SOLID R, Y, GR		HARDWARE ERROR
R, Y, GR OFF		HARDWARE ERROR
SOLID BL		SD CARD INSERTED
1X R, Y, GR		CUSTOM SYSTEM BOOT UP
1X R		ANTI-JAM ROUTINE
2X R		36 VDC OUT OF RANGE
3X R		MOTOR COMM ERROR
4X R		CHARGE COMM ERROR
5X R		BATT OUT OF RANGE
1X Y		HIGH MOTOR CURRENT
2X Y		LOW BATT VOLTAGE
3X Y		TEMP OUT OF RANGE
4X Y		5 VDC OUT OF RANGE
5X Y		GPS COMM ERROR
10X R, Y, GR		INCOMPLETE SD CARD UPDATE
1X Y, GR		GPS SATELLITE LOCK ERROR

### Power Up and Power Down Sequence

Power Down	Component	Power Up
1	On/Off Switch	6
2	PV Panels	5
3	Grid Power (Grid-Boost)	4
4	Battery	3
5	Motor Control Cord (MCC)	2
6	Motor	1

Zahn Board Green LED	
On	12 VDC to Zahn
Off	No Power to Zahn





# Troubleshooting

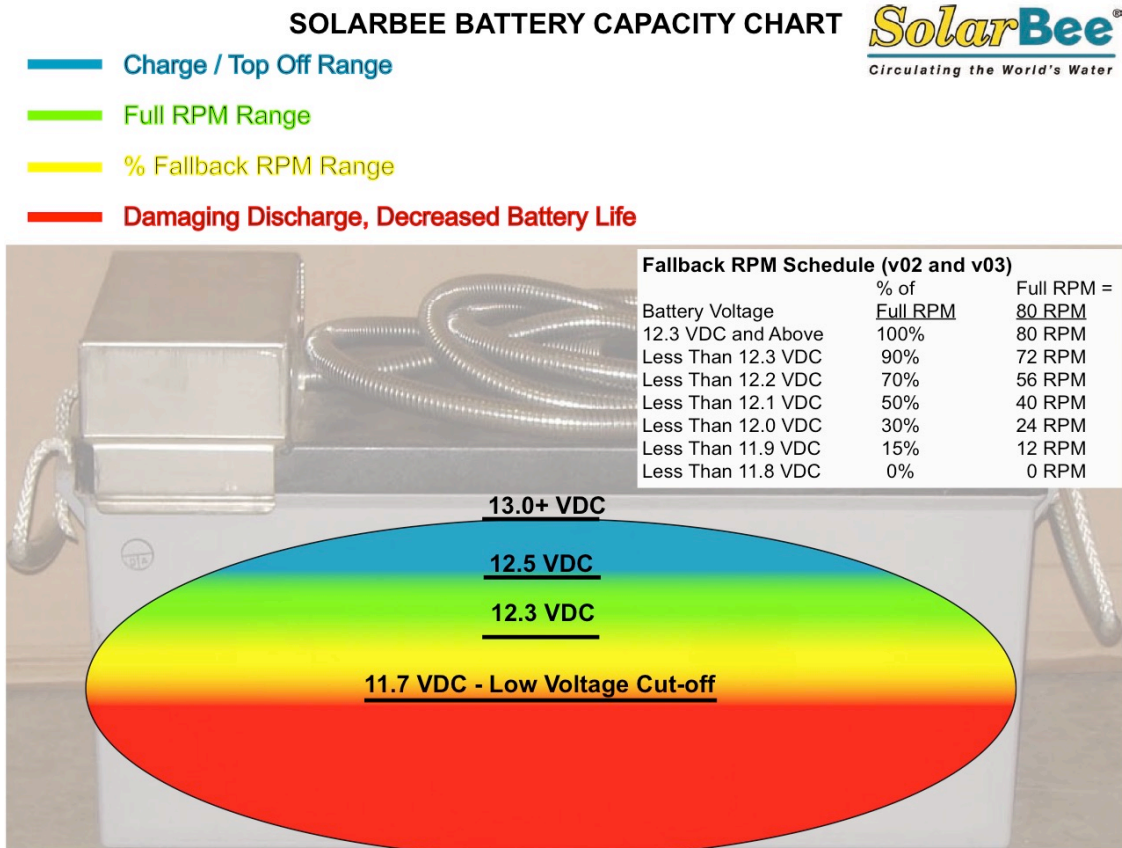
## Fallback RPM Schedule

### For Solar-Powered Floating Mixers

The below design calculations are in regards to the power conservation & continued operation mode of Ixom Watercare, Inc.'s solar-powered mixing control systems.

The SolarBee control system includes a brain board component with pre-programmed algorithms for reducing motor load and continuing operation by incremental speed reduction, thus incrementally reducing motor load and load being drawn from the battery. This feature is automatically enabled when extended low sunlight conditions occur or battery reserve power is reduced. This feature is commonly referred to as Fallback RPM.

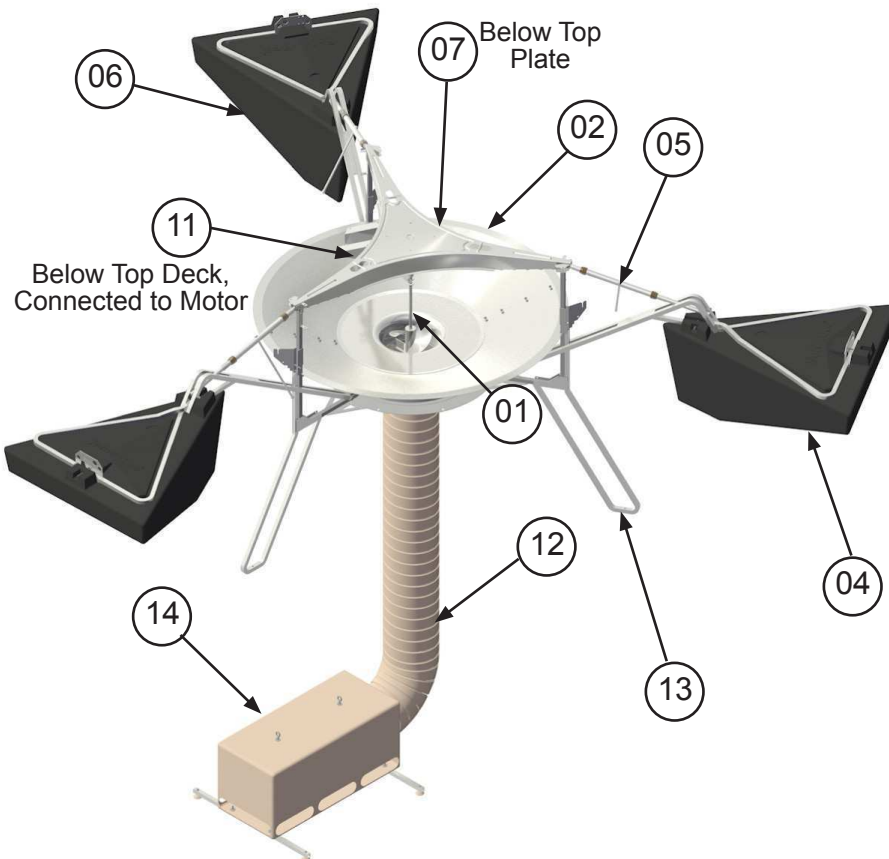
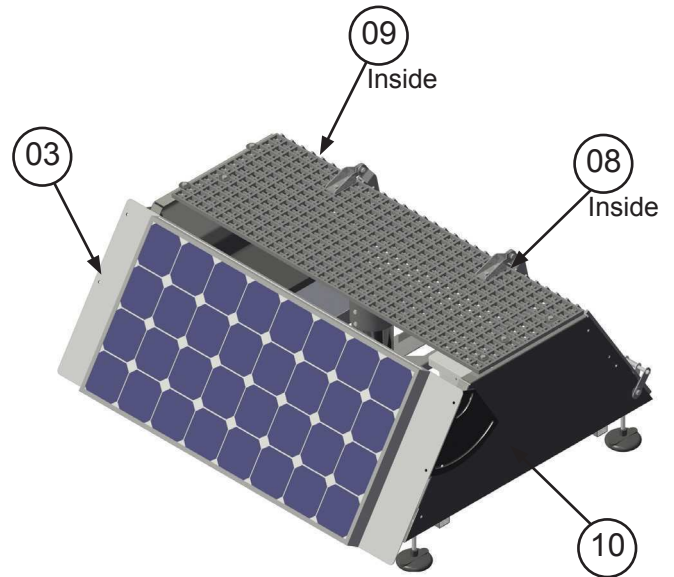
Below is the detailed Fallback RPM chart, based on battery voltage and percentage of commanded or scheduled run speed, typically programmed for full speed of 80rpm.



# Parts Diagram

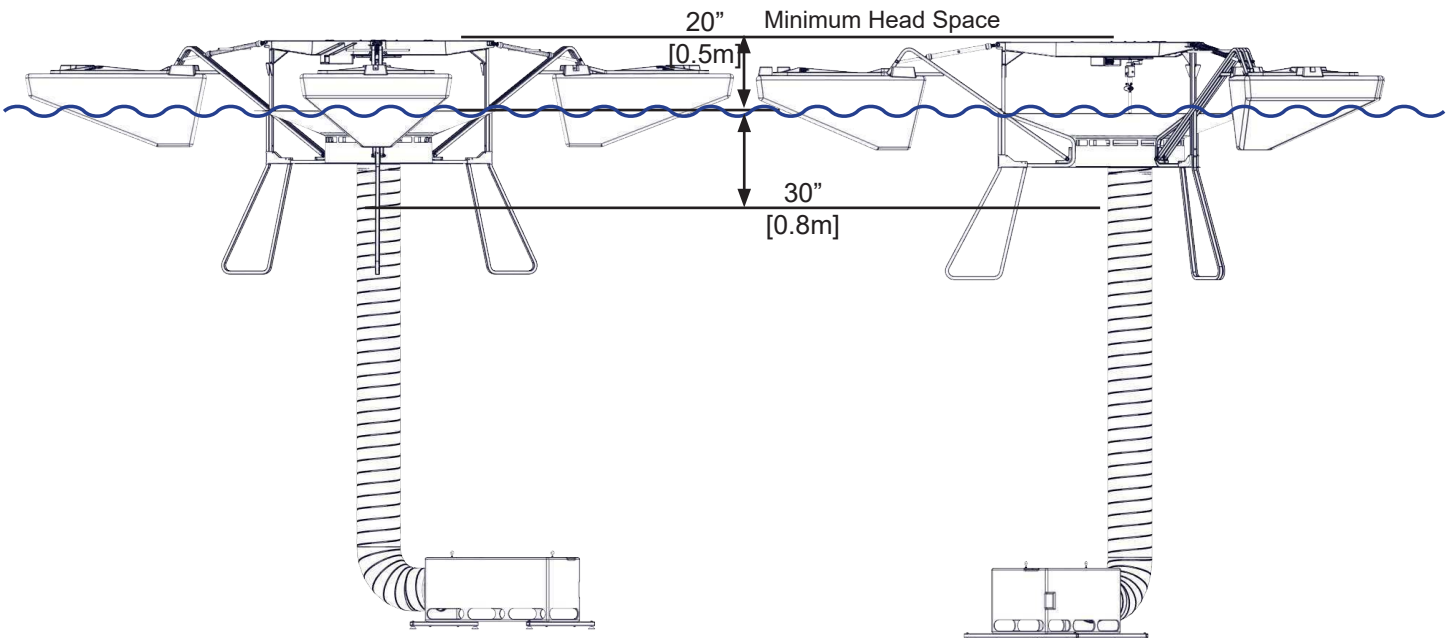
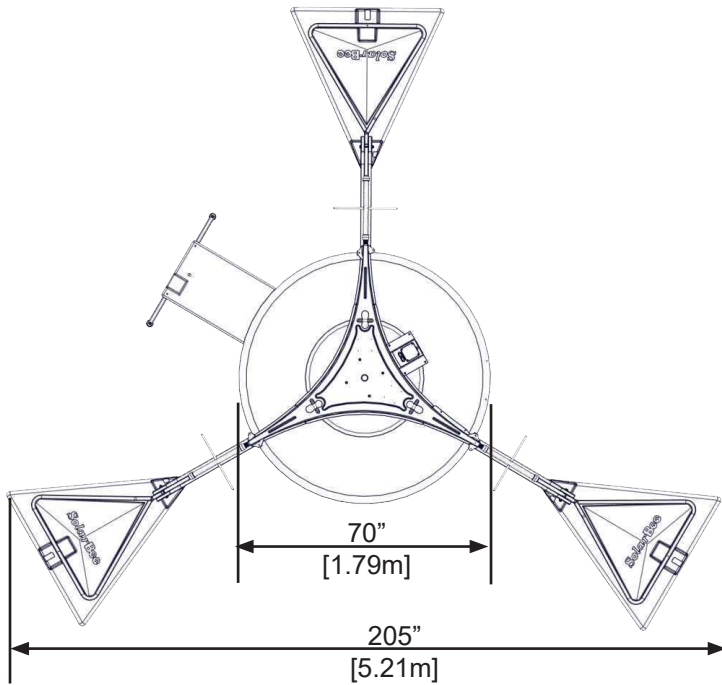
## SB2500PW Parts Diagram

NO.	PART#	DESCRIPTION
01	PN: 22281025	Impeller Assembly
02	PN: 18120002	Distributor Dish
03	PN: 100091	Solar Panel Assembly
04	PN: 18260225	Float Arm Assembly
05	PN: 18265000	Turnbuckle Assembly
06	PN: 24010100	Float
07	PN: 20504500	14" Brushless Motor
08	PN: 14285212	Battery
09	PN: 14300000	Control Box
10	PN: 18264150	Low Profile Stand
11	PN: 14013022	Motor Control Cord
12	PN: 26061220	12" x 20' NSF Hose
13	PN: 18140025	Legs, Large Frame
14	PN: 26283012	Intake Box Assembly



# Dimension Drawing

## SB2500PW Dimension Drawing



**Appendices**



**Appendix**

Additional Component Information

# Technical Data Sheets

# Technical Data Sheet

## SB2500PW

**Technology Description**- Floating, solar powered, circulation equipment for potable water reservoirs. Day/night operation on solar only by utilizing a battery to store excess daytime power for nighttime operation.

**Materials of Construction - NSF/ANSI Standard 61**- T316 stainless steel construction. Foam-filled high-density polyethylene (HDPE) floats. Thermoplastic rubber intake hose. HDPE strainer. **The SB2500PW is NSF / ANSI Standard 61 Certified, includes NSF/ANSI 61, Annex G.**



**Minimum Access Opening / Machine Size / Weight -**

Machine can be assembled through 3 feet by 3 feet (92 cm by 92 cm) clear opening. Assembled machine is 16 feet (5 m) in diameter and weighs 850 pounds (380 kg).

**Drive System** - High torque, direct drive (no gearbox), low voltage brushless D.C. motor.

**Minimum Operating Depth** - At depths below 5 feet (1.5 m), the impeller will be out of the water and the machine will stop circulating water. No damage to machine when run dry in shallow water.

**Minimum Head Space** - 30 inch (0.8 meter) headspace is required.

**Flotation System** - Three floats in triangular pattern each with an adjustable float arm for proper vertical positioning, total float buoyancy of 1,400 lbs (660 kg).

**Rotating Assembly** - Removable assembly with easy access to impeller and impeller shaft.

**Power Supply/Control System** - *Photovoltaic (PV) Solar Panels, Battery and Electronic Controller are mounted on rack outside.*

**PV Solar Panels:** 3 X 80-watt photovoltaic solar panels. Battery storage for day/night operation.

**Electronic Controller:** Digital solid-state controller, mounted in weather-tight (NEMA 4X) enclosure with externally fused disconnect. SCADA output through RS-232 serial communication (Modbus RTU), DB9 male connection point inside enclosure. Wireless options available, not included.

**Wiring:** Corrosion-resistant industrial cord with molded watertight connectors that are indexed to prevent improper wiring. Low DC voltage in reservoir, less than 36 VDC.

**Fluid Intake Assembly** - *Intake hose bolted to bottom of structural assembly.*

**Intake Hose :** 20 to 60 feet (6 to 18 m) available in 12-inch (30 cm) diameter X 20 feet (6 m) sections.

**Intake Assembly at Bottom of Hose:** Rectangular intake with openings around perimeter.

**Intake Depth Adjustment:** No depth adjustment is necessary for fluctuations in water level. Intake draws water in a horizontal layer within 1 inch (2.5 cm) of the tank or reservoir floor.

**Chlorine Boosting** - Chlorine boost hose, accessible at top of reservoir spans down and connects to intake for fast chlorine dispersion during in-reservoir boosting.

**Accessories Available** - (1) Portable Chlorine Boost System, (2) LED RPM Indicator, (3) Supplemental Power Kit, and (4) Wireless SCADA Kit.

**Shipping Size / Weight -**

- **Crate** - 87 inch W X 87 inch L X 65 inch H (2.2 m x 2.2 m x 1.7 m) / 1,500 pounds (680 kg)

*Exact weight and dimensions varies dependent on machine configuration.*

**Maintenance / Warranty** - Minimal maintenance. Limited 2-year parts and labor warranty.

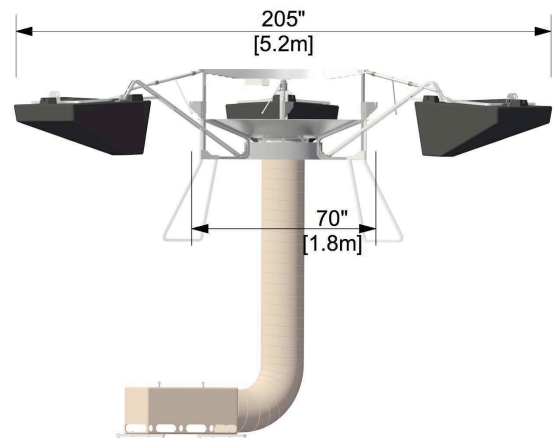


Figure 1: SB2500PW



## SB A-Series Control Panel

**Part Number: 14300000**

### Description

The SB A-Series Control Panel enables the solar powered SB units to charge a deep cycle 12VDC battery and allow continuous operation. Contains control board for autonomous control, data logging and SCADA monitoring. Also takes advantage of MPPT charging technology to ensure maximum solar power is utilized. Robust DC-DC converter to power the impeller motor.

### Power Source Required

1 to 3 - 90 W, 36 Cell Monocrystalline Solar Panels  
1 - 212 Ah, 12VDC Deep Cycle Battery

### SCADA

A SCADA output is available as a standard in RS-232 DB9 male connection and follows Modbus RTU protocol. Accessory SCADA options for other output formats may be available upon request.

### SCADA Monitoring Accessories

Additional SCADA monitoring accessories are available upon request. These include, but are not limited too, RS232-RS485 converter, wireless radios, and Modbus Master converter.

### Enclosure

10 inch X 8 inch X 6 inch, NEMA 4X Fiberglass  
Mounting Feet Hole Pattern: 7.01" W X 11.19" H  
Back Plate Hole Pattern: 6.25 inch W X 8.25 inch H

### Shipping Size/Weight

16 inch X 13 inch X 11 inch, 16 lbs

### Warranty

Reference SB Limited Replacement Warranty.

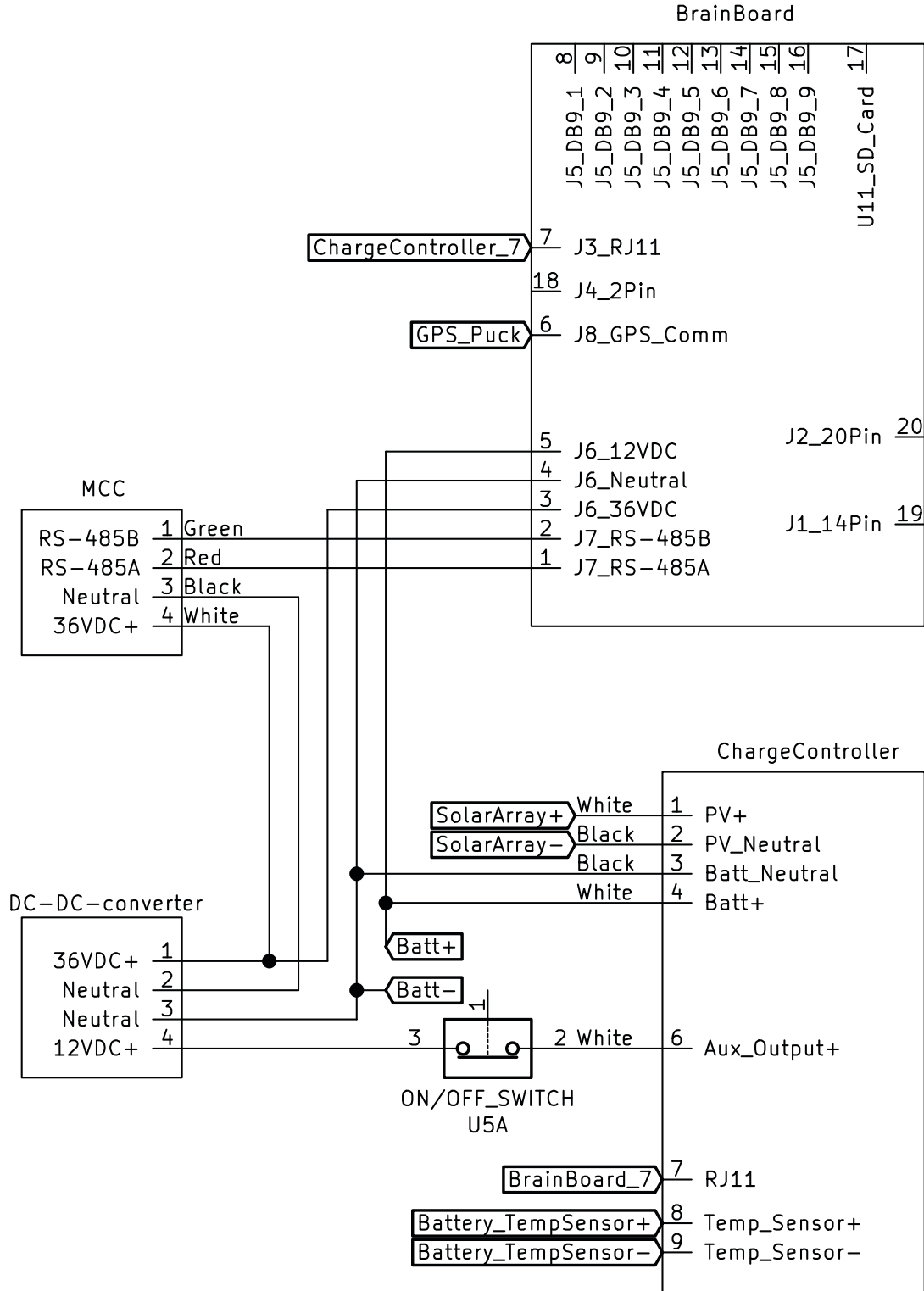


*Figure 1: SB A-Series Control Panel, External*



*Figure 2: SB A-Series Control Panel, Internal*

# SB Series A-Box Wiring Schematic

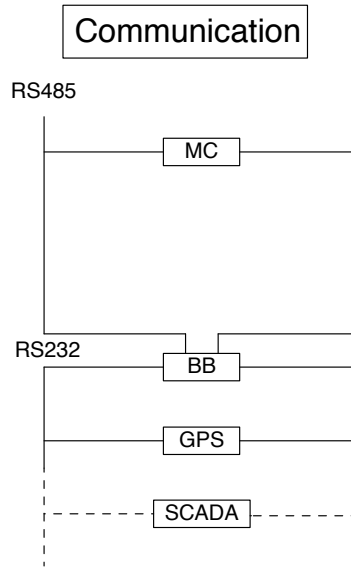
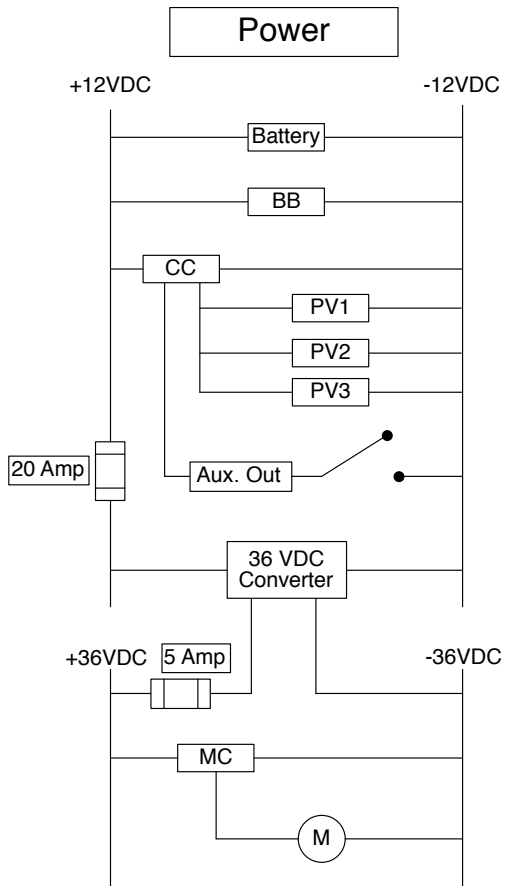


# Electrical

## Electrical Schematic

SB Series - A Box

Key	
MC	Motor Controller
BB	Brain Board
M	Motor
PV	Photovoltaic Panel



## SB B-Series Control Panel

**Part Number: 14300005**

### Description

The SB B-Series Control Panel enables the solar powered SB units to charge a deep cycle 12VDC battery and allow continuous operation. Also utilizes supplemental grid power from the shore. Contains control board for autonomous control, data logging and SCADA monitoring. Also takes advantage of MPPT charging technology to ensure maximum solar power is utilized. Robust DC-DC converter to power the impeller motor.

### Power Source Required

- 1 to 3 - 90 W, 36 Cell Monocrystalline Solar Panels
- 1 - 212 Ah, 12VDC Deep Cycle Battery
- 1 - Supplemental 36VDC Shore Power (Additional Shore Power Box Needed)

### SCADA

A SCADA output is available as a standard in RS-232 DB9 male connection and follows Modbus RTU protocol. Accessory SCADA options for other output formats may be available upon request.

### SCADA Monitoring Accessories

Additional SCADA monitoring accessories are available upon request. These include, but are not limited too, RS232-RS485 converter, wireless radios, and Modbus Master converter.

### Enclosure

10 inch X 8 inch X 6 inch, NEMA 4X Fiberglass  
Mounting Feet Hole Pattern: 7.01" W X 11.19" H  
Back Plate Hole Pattern: 6.25 inch W X 8.25 inch H

### Shipping Size/Weight

16 inch X 13 inch X 11 inch, 16 lbs

### Warranty

Reference SB Limited Replacement Warranty.



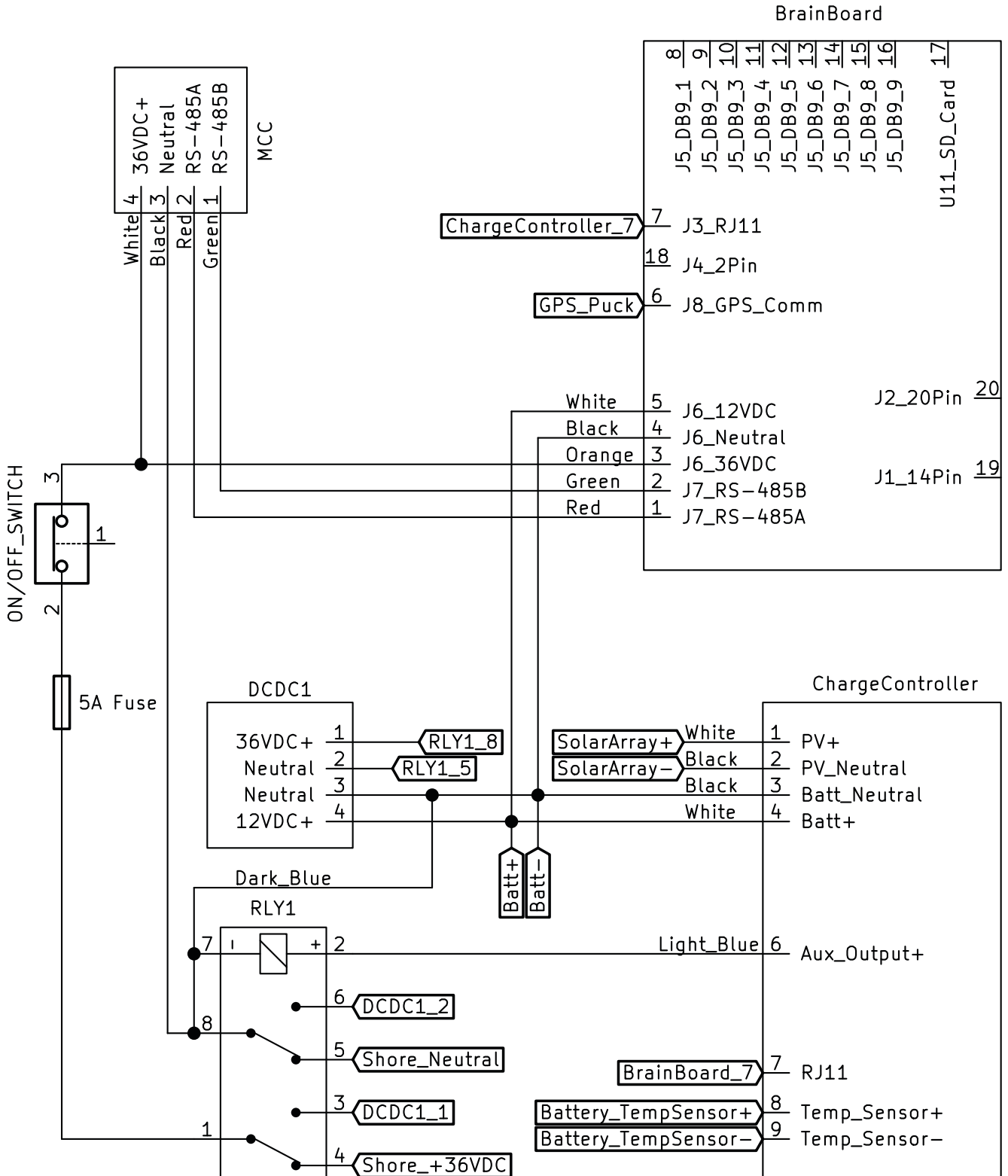
*Figure 1: SB B-Series Control Panel, External*



*Figure 2: SB B-Series Control Panel, Internal*

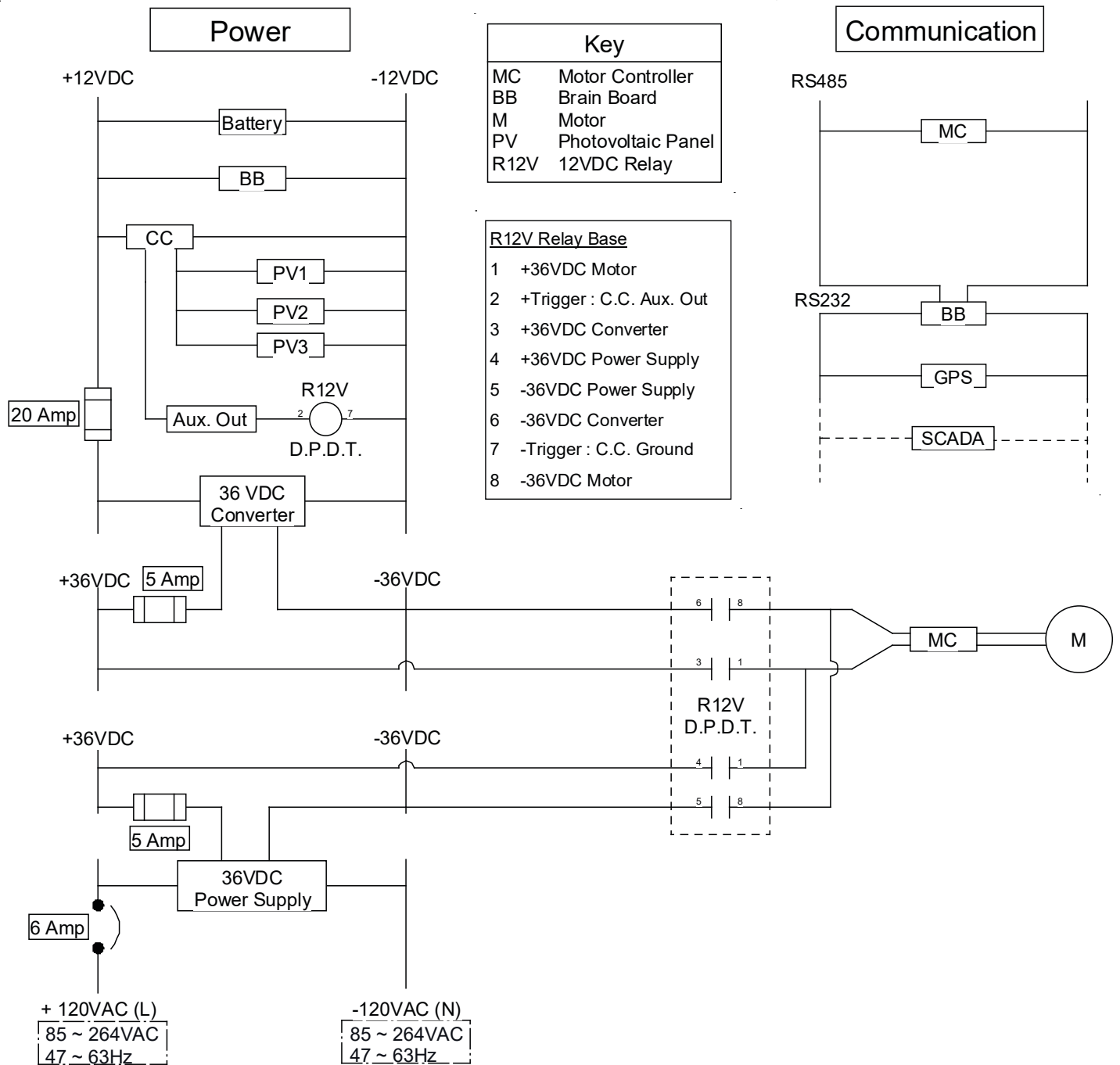


# SB Series B-Box Wiring Schematic



## Electrical Schematic

SB Series - B Box - Grid Boost



## SolarBee Standard SCADA Output

The SolarBee digital controller comes standard with the following SCADA output capabilities: Controller shall have RS-232 serial communication (Modbus RTU), DB9 male connection point.

Parameters available for monitoring:

- 1) System Status (OK or Fault)
- 2) Visual Status Indicator
- 3) Motor RPM & Direction
- 4) Motor Current
- 5) Battery Voltage
- 6) Input Charge Current

### SCADA Accessory Packages:

- Wireless Radio
- Analog Output
- RS-232 to RS-485 Converter
- LED RPM Indicator

---

## SolarBee Monitoring Setup Information

The SolarBee is a modbus RTU slave device with a factory programmable slave ID. The ID can be changed in the field with a properly programmed SD card. Contact Ixom Watercare, Inc. Customer Service for assistance.

### Serial Interface

Type: RS-232

Connector: 9 pin male D-Sub

Pin assignments:

- |   |   |
|---|---|
| 1 | n/c   |
| 2 | RXD      Receive Data Input                                     |
| 3 | TXD      Transmit Data Output                                   |
| 4 | n/c   |
| 5 | Signal Ground   |
| 6 | n/c   |
| 7 | n/c   |
| 8 | n/c   |
| 9 | +12VDC, 1 Amp max<br>(Can be used to power some serial devices) |

### Serial/modbus Communication Parameters

Rate: 19200 Baud

Bits/byte: 8

Stop bits: 1

Parity: N (none)

Handshake: None

Time between bytes sent to SolarBee controller:  
No greater than 20 milliseconds

Time between commands sent to SolarBee controller:  
At least 50 milliseconds

### Read Holding Register

The SolarBee supports modbus Function 3 - Read Holding Register.

A properly formatted "Read Holding Register" modbus message will be replied to with holding register data. The "Read Holding Register" message consists of the SolarBee slave address, the function (3), two bytes of register address, two bytes of number of points, and the CRC. The address of the holding registers can be found in the table on the next page.

The format of the reply consists of the SolarBee slave address, the function (3), a byte count (number of data bytes), two bytes of data for each of the requested points, and the CRC.

When monitoring several SolarBees on the same modbus network, query them sequentially. That is, query one SolarBee and wait for its response, query the next SolarBee and wait for its response, etc. Querying the SolarBees in a manner such that the query/response messages can overlap or collide will cause inconsistent communication.

## SolarBee Standard SCADA Output

### Description of Holding Registers in Order of Importance

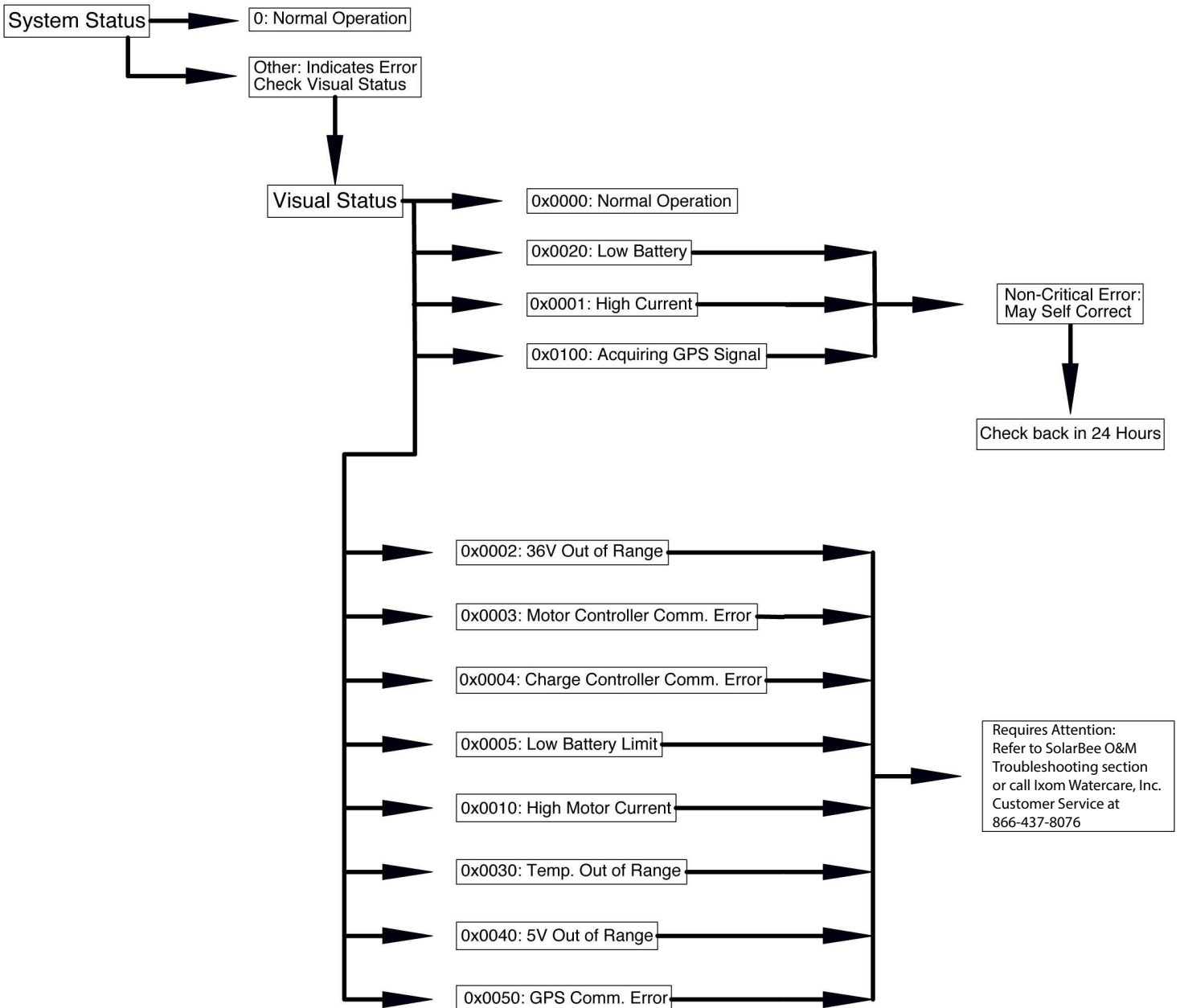
(Memory Table starts at zero, 0)

Register Address (Base 10)	Status Item	Description
4	Current Epoch High	This is the date and time data for the SolarBee. The format is the same as that of the “Unix epoch”, (Epoch High * 65536 + Epoch Low), where the value is the number of seconds since 00:00:00 UTC on January 1, 1970. This value is set by the GPS hardware in the SolarBee controller.  Querying register 5 and testing the response against the previous value is a good way to monitor the communication link between the modbus master and the slave SolarBee controller.
5	Current Epoch Low	
7	System Status	During normal operation this value is 0 (Zero). Any other number indicates an error. It is important to monitor this register since the SolarBee controller reports last known values it received from subsystem modules. For example, if the SolarBee controller loses communication with the motor control module, it will indicate this in this system status register but continue to report the last known motor RPM and current values.
9	Visual Status Indicator	This value gives an indication of the SolarBee controller health blink indicator. During normal operation the following values will appear: 0 = (1 Blink Green = Healthy System) 32 = (2 Blink Yellow = Low Battery, Healthy System) 1 = (1 Blink Red = AntiJam Sequence), high current may self correct 256 = (1 Blink Green & 1 Blink Yellow = Acquiring GPS Satellite Signal)  Any other indication requires attention: 2 = (2 Blink Red = 36V Out Of Range) 3 = (3 Blink Red = Motor Controller Communication Error) 4 = (4 Blink Red = Charge Controller Communication Error) 5 = (5 Blink Red = Low Battery Limit) 16 = (1 Blink Yellow = High Motor Current) 48 = (3 Blink Yellow = Temperature Out Of Range) 64 = (4 Blink Yellow = 5V Out Of Range) 80 = (5 Blink Yellow = GPS Communication Error)
10	Motor Speed	The unit for this value is RPM in hundredths. To obtain RPM, divide the value by 100.
11	Motor Direction	The value of 0 indicates that the motor will be stopped, the value of 1 represents movement in the forward direction, whereas the value of 3 indicates reverse movement. Viewed from behind or above the motor clockwise motion is “forward”.
12	Motor Current	The unit for this value is milliamps.
13	Battery Voltage	The unit for this value is Volts. The value is scaled using this formula: value / 10.
14	Input Current	The current that is input to the controller via the solar array or shore power connections. The unit for this value is Amps. The value is scaled using this formula: value / 10.



# SolarBee Standard SCADA Output

## Logic Diagram



# System Status for SolarBee SCADA Integration

## Register Address 7 (Base 10)

Value of Zero indicates normal, healthy operation. Any other value indicates a subsystem or multiple subsystem errors. See below.

Binary Designation(s)	Decimal Value	Error Meaning
Bit 0 = 1	1	GPS Communication (Comm) Error
Bit 1 = 1	2	Charge Controller Comm Error
Bits 0 and 1 = 1	3	GPS Comm and Charge Controller Comm Error
Bit 2 = 1	4	Motor Comm Error
Bits 0 and 2 = 1	5	GPS Comm and Motor Comm Error
Bits 1 and 2 = 1	6	Charge Controller Comm and Motor Comm Error
Bits 0, 1, and 2 = 1	7	GPS Comm, Charge Controller Comm, and Motor Comm Error
Bit 3 = 1	8	Analog Out of Range (OOR) Error
Bits 0 and 3 = 1	9	GPS Comm and Analog OOR Error
Bits 1 and 3 = 1	10	Charge Controller Comm and Analog OOR Error
Bits 0, 1, and 3 = 1	11	GPS Comm, Charge Controller Comm, and Analog OOR Error
Bits 2 and 3 = 1	12	Motor Comm and Analog OOR Error
Bits 0, 2, and 3 = 1	13	GPS Comm, Motor Comm, and Analog OOR Error
Bits 1, 2, and 3 = 1	14	Charge Controller Comm, Motor Comm, and Analog OOR Error
Bits 0, 1, 2, and 3 = 1	15	GPS Comm, Charge Controller Comm, Motor Comm, and Analog OOR Error

For Customer Service, contact Ixom Watercare, Inc. Main Office and Service Center at 866-437-8076.

# Visual Status Indicator Priority Levels

Register Address 9 (Base 10)

Table 4 - Status Indicator Priority Levels		
Priority Level	LED Behavior	Indication / Cause
Priority 1	5x Red	Battery Voltage is Out of Range: Vbat < <b>Analog Battery Monitor Lower Limit</b> (11.4V) or Vbat > <b>Analog Battery Monitor Upper Limit</b> (17.5V)
Priority 2	1X Red	AntiJam Mode has been activated: Motor Current > <b>AntiJam A Trigger Current</b> (4.5A) or Motor Controller Error has been received.
Priority 3	2X Red	36V Supply is Out of Range: 36V supply < <b>Analog 36V Monitor Lower Limit</b> (33.0V) or 36V supply > <b>Analog 36V Monitor Upper Limit</b> (39.0V). If the Charge Controller has the Auxiliary Output turned off, this error is not displayed.
Priority 4	3X Red	Motor Controller not communicating properly. If the Charge Controller has the Auxiliary Output turned off, this error is not displayed.
Priority 5	4X Red	Charge Controller not communication properly.
Priority 6	1X Yellow	Motor Current > <b>Visual Motor Current Threshold</b> (3.5A)
Priority 7	2X Yellow	Vbat < <b>Visual Low Battery Threshold</b> (12.1V)
Priority 8	3X Yellow	Temperature Reading is Out of Range: Temp < <b>Analog Temperature Monitor Lower Limit</b> (0°F) or Temp > <b>Analog Temperature Monitor Upper Limit</b> (176°F)
Priority 9	4X Yellow	5V Supply is Out of Range: 5V supply < <b>Analog 5V Monitor Lower Limit</b> (4.5V) or 5V supply < <b>Analog 5V Monitor Upper Limit</b> (5.5V)
Priority 10	5X Yellow	GPS Unit not communicating properly

## Large 14" Brushless Motor

### Motor Features

**Technology Description-** Designed for Solarbee and Gridbee circulation equipment. The brushless direct drive motor provides high torque, eliminates costly gearboxes, and provides high reliability. The motor requires no brush replacement, no lubrication, and no routine maintenance. An iron free stator eliminates iron saturation to provide long life. It also provides a smooth, vibration free operation. Quite operation at low speeds. Operational power requirements utilize low voltage DC power. Using hall effects for electronic communication. Provides effective use of solar and DC energy.

14" Motor Specifications		
Size	14-inch (36cm) diameter X 6-inch (15cm) height	
Weight	75 lb (34 kg)	
Housing	Sealed 356-T6 Cast Aluminum	
Shaft	Stainless Steel: V-ring seal	
Thrust Bearing	L10: 100,000 hrs. Stainless Steel	
Motor Control	Anti-Corrosive coating on flux returns and magnets Encapsulated stator Conformal coating on commutation circuit board Hall Effect Commutation	
Receptacle	#16-9, 7A, 600V AC/DC, IP68, NEMA 6P, UL/CSA	
	<b>Normal Operation</b>	<b>Maximum Motor Ratings</b>
Current	<b>Less Than 1.0 Amp</b>	7.0 Amps
Voltage	<b>36 VDC</b>	36 VDC
Torque	<b>3ft-lb (0.4 N-m)</b>	30 ft-lb (40 N-m)
Power	<b>1/20 HP (36 W)</b>	1/3 HP (250 W)
Environment	<b>-40 to 140°F, freeze resistant, 100% humidity, splash and condensation resistant</b>	



#### Shipping Size/Weight

- 16" x 16" x 9", 80lbs.

**Maintenance / Warranty** - No routine maintenance. Limited 2-year parts and labor warranty.



# Technical Data Sheet



## Sun Xtender Submersible Solar Battery

**PART NUMBER:** 14285212

**DESCRIPTION:**

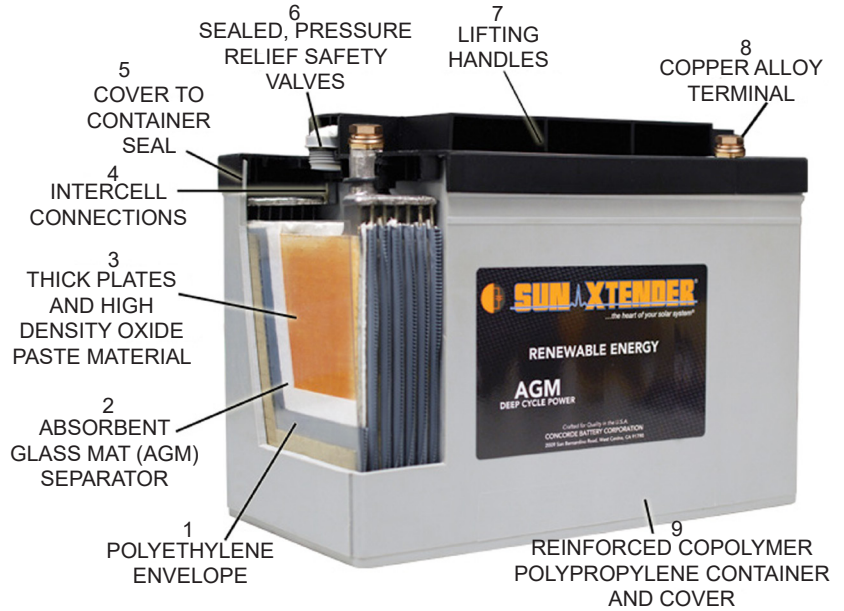
Core Manufacturer: Concord Corp.  
Sun Xtender Solar Battery, VRLA-AGM Deep Cycle Battery for Off Grid and Grid Tied Systems

**CONSTRUCTION:**

Thick walled polypropylene copolymer container and sealed cover. PolyGuard protection used around the positive plate and AGM prevents shorting from shock and vibration. Sun Xtender is the only battery offering this added layer of protection. Recombinant gas Sun Xtender® Series solar batteries are valve regulated lead acid (VRLA) batteries, providing explosion resistance.

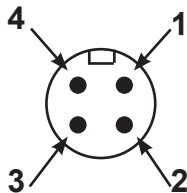
**APPROVALS:**

UL 1989 (Standby Battery), File Number MH-17983. Sun Xtender® Series batteries ship Hazmat EXEMPT. Complies with 49 CFR 173.159a, DOT HMR49, ICAO and IATA, Special Provisions S.P.A67 & A48.



1. Eliminates internal shorts caused by shock, vibration & dendrite growth.
2. Custom designed and manufactured to provide superior wicking characteristics for electrolyte retention.
3. Insures long life, excellent cycling capability.
4. Massive "over-the-partition" weld increases the weld strength & provides low resistance connection path.
5. Strong, epoxied tongue & groove cover/container seal will not separate even under extreme temperature & pressure changes or vibration.
6. Operates in any orientation without leaking. Maintenance-free: never requires water additions.
7. Easier handling, carrying & installation.
8. Provides low resistance electrical connection (copper-to-copper), non-corrosive, increased environmental protection & personal safety- no exposed lead.
9. High impact resistance and resists bulging even under severe overcharge and temperature. Shock proof and freeze tolerant.

**4 PIN MALE FACE VIEW**

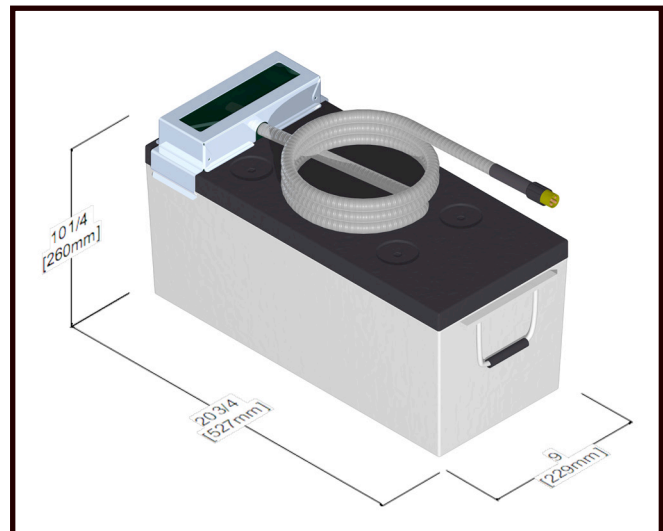


- |            |       |                    |
|------------|-------|--------------------|
| 1 - 12 AWG | Black | -12VDC Power       |
| 2 - 12 AWG | Green | Temperature Sensor |
| 3 - 12 AWG | Red   | Temperature Sensor |
| 4 - 12 AWG | White | +12VDC Power       |

**Electrical and Physical Properties:**

**Voltage:** 12V  
**Weight:** 145 lb (65.77 kg)  
**Battery Series:** 12 Volt Sun Xtender Series  
**Cord Length:** 7 ft T316 SS Sheathed  
**Self Discharge Rate:** 1-3%/month - remains stable over life.  
**IP Rating:** IP68  
**Nominal Capacity Ampere Hours:**  
 @ 25° C (77° F) to 1.75 Volts per cell

24 Hr Rate: 212Ah  
 48 Hr Rate: 235Ah  
 72 Hr Rate: 244Ah



## Warranty



### Solar SB Mixers

#### Limited Replacement Warranty

**SolarBee SB Mixers.** All new and factory-refurbished SolarBee SB mixers and circulators are warranted to be free of defective parts, materials, and workmanship for a period of two years from the date of installation. SolarBee SCADA and any optional accessories are considered “buyout” items for Ixom, and as such include a warranty against defects in material and workmanship for two years from the date of purchase. Parts that are determined by Ixom to be defective in material or workmanship under normal use during the two year warranty period will be repaired or replaced. Any shipping charges that may apply are the responsibility of the customer. This warranty is valid only for SolarBee equipment used in accordance with the owner’s manual, and consistent with any initial and ongoing factory recommendations. This warranty is limited to the repair or replacement of defective components only and does not apply to normal wear and tear. If the factory’s service crews performed the original on-site placement and startup, then this warranty also includes labor. Where labor is included, in lieu of sending a factory service crew to the site for minor repairs, Ixom may choose to send the replacement parts to the owner postage-paid and may pay the owner a reasonable labor allowance, as determined solely by Ixom, to install the parts. There is no liability for consequential damages of any type. The warranty that is submitted and provided with the purchased equipment is the valid warranty.

**Terms applicable to all equipment.** This Limited Replacement Warranty is subject to the terms of Ixom’s General Terms and Conditions of Sale. In the event of any inconsistency between the terms of this Limited Replacement Warranty and Ixom’s General Terms and Conditions of Sale, the terms of this Limited Replacement Warranty shall prevail to the extent of that inconsistency.

# Protect Your Investment With The Ixom Service Program

## Comprehensive Damage Repair

Damage which occurs to your Ixom manufactured equipment in the normal course of operation will be repaired or replaced including supply and installation of structural repairs and replacement parts in accordance with Ixom's standard terms & conditions.

## Trained & Experienced Service Technicians

The Ixom Service Program allows our customers to take advantage of our highly trained service technicians. We have the equipment, experience and training to ensure the machines are well maintained while following OSHA regulations. Our dedication to safety and high level of training has earned us the prestigious SHARP recognition award time and time again. We have the means to safely service the equipment whether in municipal water tanks, lakes, reservoirs, or wastewater ponds & basins.



## Guaranteed Annual Onsite Maintenance

Ixom service personnel will perform a minimum of one (1) onsite equipment inspection & maintenance per yearly term of the service contract including mechanical, structural, and electronic components of Ixom manufactured equipment.

## On-Site Crew Response for Critical Application and Operational Service Issues

If service issues arise, the customer may be asked to perform a basic machine inspection and discuss results with Ixom's Customer Service Department. In some cases, the customer may be asked to perform minor tasks (i.e., cleaning, basic troubleshooting, and replacing minor parts). If replacement parts are needed, the factory will ship them out at no cost. For more serious application and service issues, Ixom will dispatch service personnel to resolve the issues onsite.



## Removal, Storage, and Redeployment of Equipment

For situations when Ixom equipment needs to be removed, stored, and redeployed, services can be offered at a discounted rate.

## Access to On-Staff Water Quality Experts

Ixom employs many experts in the water quality field including specialized areas such as limnology, hydrology, wastewater, biology, and engineering. Our water quality personnel are available for data analysis and troubleshooting when you need it.



**Contact us for a quote!**

Call +1 866-437-8076 or email us at [watercare@ixom.com](mailto:watercare@ixom.com)



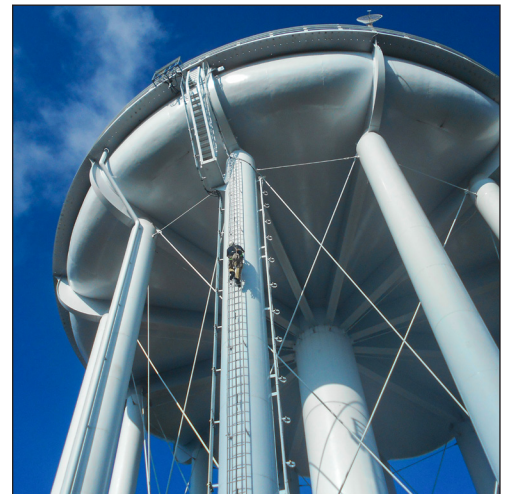
# IXOM

## WATERCARE

## Nationwide Installation & Service

### EVERYONE DESERVES GREAT CUSTOMER SUPPORT

Ixom Watercare earns customer trust with unparalleled service start to finish. Every department in Ixom is dedicated to the support of our Customers and the improvement of water quality. Complete life cycle support is much, much more than a returned phone call or an email. It centers around direct access and communication to those who can help when help is needed from the beginning of a project throughout the life of the equipment.



### ABOUT IXOM

Ixom combines innovative water quality solutions with top notch manufacturing and nationwide in-field service capabilities to create trusted, full circle support our Customers depend on.

We design and manufacture many trusted brands including GridBee®, SolarBee®, MIEX®, and ResidualHQ® for use across the water quality spectrum. This includes solutions for Water Treatment, Distribution Treatment, Wastewater Treatment and Lakes & Source Water Reservoirs.

Ixom has thousands of installations and is an industry-leader solving water quality problems across the United States, Canada and the world.

**Contact us today to discuss your water quality and service needs.**

[ixomwatercare.com](http://ixomwatercare.com)

866-437-8076 • [watercare@ixom.com](mailto:watercare@ixom.com)