

F8 Ventilation Blower

Owner's Manual

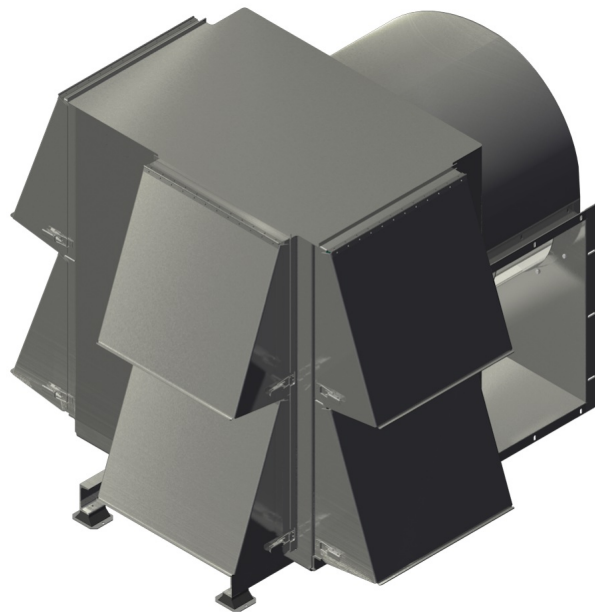

F8 Ventilation Blower

Owner's Manual

Safety	1
Technical Specifications	4
Performance Curves	5
Exploded Parts Diagram	6
Integration	7
Blower Ducting	9
Startup and Operation	10
Maintenance	12
Warranty	13
Customer Service	14

Safety

IMPORTANT

**YOU MUST COMPLETELY
READ AND FULLY
UNDERSTAND THESE
INSTRUCTIONS BEFORE
INSTALLING, OPERATING,
OR SERVICING THIS UNIT.**

Be sure you have read all installation, operation, maintenance and safety instructions before you install, service or begin to operate this unit.

Accidents occur every year because of careless use of industrial equipment. You can avoid hazards by following these safety instructions, and applying some ordinary common sense when operating or servicing this unit.

Keep in mind that **full operator attention and alertness** are required when operating or servicing this unit.

USE COMMON SENSE!! Most accidents can be avoided by using **common sense and concentration** on the job being done.



Carefully read safety information when you see any safety symbols.



Safety

IMPORTANT

YOU MUST COMPLETELY READ AND FULLY UNDERSTAND THESE INSTRUCTIONS BEFORE INSTALLING, OPERATING, OR SERVICING THIS UNIT.

Identify all possible hazards. Determine what safeguards are needed and implement them. **Only you, the user,** understand your product and system characteristics fully. *The ultimate responsibility for safety is with you. Your safety ultimately rests in your hands.* Do your part and you will enjoy safe, trouble free operation for years to come. This instruction manual is not intended to include a comprehensive listing of all details for all procedures required for placement, operation and maintenance. If you have a question about a procedure or are uncertain about any detail, **Do Not Proceed.** Please contact Ixom Watercare Customer Service at **866-437-8076** to speak to a representative.



IMPORTANT!!!

Follow all federal and state laws in regards to safety regulations of working at heights, confined spaces, rescue, etc. as required by the U.S. Department of Labor, Occupational Safety and Health Administration. Use necessary PPE when placing and servicing this unit.



Thin Ice Hazard

WARNING: ICE SURROUNDING MACHINE MAY NOT SUPPORT WEIGHT, KEEP CLEAR OF THIN ICE.



ELECTRICAL HAZARD

WARNING: THIS EQUIPMENT CONTAINS HIGH VOLTAGE! ELECTRICAL SHOCK CAN CAUSE SERIOUS OR FATAL INJURY. ONLY QUALIFIED PERSONNEL SHOULD ATTEMPT PLACEMENT, OPERATION AND MAINTENANCE OF ELECTRICAL EQUIPMENT. REMOVE ALL SOURCES OF ELECTRICAL POWER BEFORE PERFORMING ANY SERVICE WORK TO THE MACHINE. USE PROPER LOCKOUT TAGOUT (LOTO) PROCEDURES TO ENSURE A SAFE WORK ENVIRONMENT.



Crush Hazard

WARNING: DO NOT REMOVE ANY FLOAT ASSEMBLY BOLTS OR PINS WHILE EQUIPMENT IS FLOATING IN WATER. EQUIPMENT MUST BE SECURELY SUPPORTED BEFORE PERFORMING SERVICE.



Rotating Hazard

CAUTION: KEEP BODY APPENANDAGES OR LOOSE CLOTHING AWAY FROM EQUIPMENT WHILE OPERATING. ENSURE EQUIPMENT IS OFF BEFORE ATTEMPTING SERVICE.



Entanglement Hazard

WARNING: ENSURE THAT PERSONNEL ARE CLEAR OF THE ELECTRIC CORD AND CHAIN TO AVOID ENTANGLEMENT.



Laceration Hazard

CAUTION: EDGES MAY BE SHARP AND CAUSE LACERATION IF PROPER CARE IS NOT USED.

Safety

Protect Yourself

It is important that you comply with all relative OSHA and local regulations while installing and performing any maintenance to the mixer circulation equipment.

Key OSHA Compliance Standards that must be followed (and not limited to) are:

- **1910.146 Permit-required confined spaces**
- **1910.147 Lockout/Tagout**
- **1926.500 Fall Protection**

Fall Protection Tips

- Identify all potential tripping and fall hazards before work starts.
- Look for fall hazards such as unprotected floor openings/edges, shafts, open hatches, stairwells, and roof openings/edges.
- Inspect fall protection and rescue equipment for defects before use.
- Select, wear, and use fall protection and rescue equipment appropriate for the task.
- Secure and stabilize all ladders before climbing.
- Never stand on the top rung/step of a ladder.
- Use handrails when you go up or down stairs.
- Practice good housekeeping. Keep cords, welding leads and air hoses out of walkways or adjacent work areas.

Refer to 29 CFR 1926.500 for complete regulations set by OSHA. Refer to your state's regulations if your state established and operates their own safety and health programs approved by OSHA.

Lockout Tagout

When the On/Off switch is in the "ON" position, the mixer may start up at any time if not already operating. The mixer's On/Off switch can be locked out by placing a pad lock thru the door latch of the controller after the switch has been turned to the "OFF" position. The On/Off switch is to be used as the emergency stop.



Permit-Required Confined Spaces

A confined space has limited openings for entry or exit, is large enough for entering and working, and is not designed for continuous worker occupancy. Confined spaces include underground reservoirs, ground storage tanks, elevated tanks, silos, manholes, and pipelines.

Confined Space Tips

- Do not enter permit-required confined spaces without being trained and without having a permit to enter.
- Review, understand and follow employer's procedures before entering permit-required confined spaces and know how and when to exit.
- Before entry, identify any physical hazards.
- Before and during entry, test and monitor for oxygen content, flammability, toxicity or explosive hazards as necessary.
- Use fall protection, rescue, air monitoring, ventilation, lighting and communication equipment according to entry procedures.
- Maintain contact at all times with a trained attendant either visually, via phone, or by two-way radio. This monitoring system enables the attendant and entry supervisor to order you to evacuate and to alert appropriately trained rescue personnel to rescue entrants when needed.

Refer to 29 CFR 1910.146 for complete regulations set by OSHA. Refer to your state's regulations if your state established and operates their own safety and health programs approved by OSHA.

F8 Ventilation Blower

Technology Description- Centrifugal blower and filter housing assembly with electric motor. Filtered air intake, distributes air inside tank for ventilation of tank head space, designed to evacuate volatilized THM's, gases and other contaminants from the head space.

Part Number - 100716

Materials of Construction - T316 stainless steel, with gray epoxy or powder coating.

Duct Sizing Requirement - Ø 18" minimum or equivalent open space. (Ø 24" recommended.)

Air Filters - Six Filter Elements, 98%+ removal efficiency to 10 micron, synthetic felt air filter. Each rated for 3000 CFM (85 m³/min), 30ft² surface area, washable, galvanized steel reinforcement frame. Dimensions: 24" X 24" X 2"
Replacement Filters PN: 20012066

Air Flow Rate - Tank gravity vents must allow for 250 square inch (after screens and mesh) minimum open surface area per blower.



Figure 1: F8 Blower

Blower Performance (SCFM) at varying Static Pressures (Inches of Water)				
0"	1"	2"	3"	4"
5250	4500	3800	3400	3000

Vibration Isolation - Secured to T316SS skid, separated by rubber isolation pads properly sized for blower weight and operation.

Mounting - Vibration isolation pads anchor to flat concrete surface via concrete wedge anchors. Minimum 8ft x 8ft x 6in concrete pad or footprint required.

Electrical Requirements - Requires 240VAC single-phase or 240VAC or 480VAC three-phase, 60Hz power. 600VAC three-phase 60Hz power requires special motor. Ixom recommends secondary disconnect to be located near blower equipment. Three-phase motor protection is recommended. *All conduit, conductors, switches, breakers, emergency stop buttons, control panels and other controls shall be installed in accordance to all NEC, State, and local regulations. (Not supplied by Ixom.)*

Motor - 3HP Baldor TEFC, 1770rpm induction motor, designed for continuous operation, low power requirement, direct drive, no gearbox and no lubrication schedule required. No heater. Estimated Decibel - 80dB @ 5ft, 70dB @ 25ft, 55dB @ 100ft. Max Amps: 3.40 A @ 575 VAC/3PH ***Special Motor**, 4.20 A @ 460 VAC/3PH, 8.40 A @ 230 VAC/3PH, 9.00 A @ 208 VAC/3PH, 15.5 A @ 230 VAC/1PH.

Coupling and Bearings - Double supported fan wheel using quality Baldor Dodge pillow block bearings and coupling.

Wiring - 4-conductors required (L1, L2, L3, Gnd). Electrical TEFC motor wiring box for conduit connection and electrical splicing. Multiple locations available for conduit entry through air filter housing.

Shipping Size / Weight

• **Crate** - 86in x 86in x 64in (2.2 m x 2.2 m x 1.6 m) / 1500 lbs (680 kg). *Exact weight and dimensions may vary dependent on blower and roof mount configuration.*

Maintenance / Warranty - Limited maintenance. Limited 2-year warranty. See GridBee THM Removal Systems Limited Replacement Warranty for more details.

Subject to change without notice.

F-SERIES BLOWER PERFORMANCE CURVES

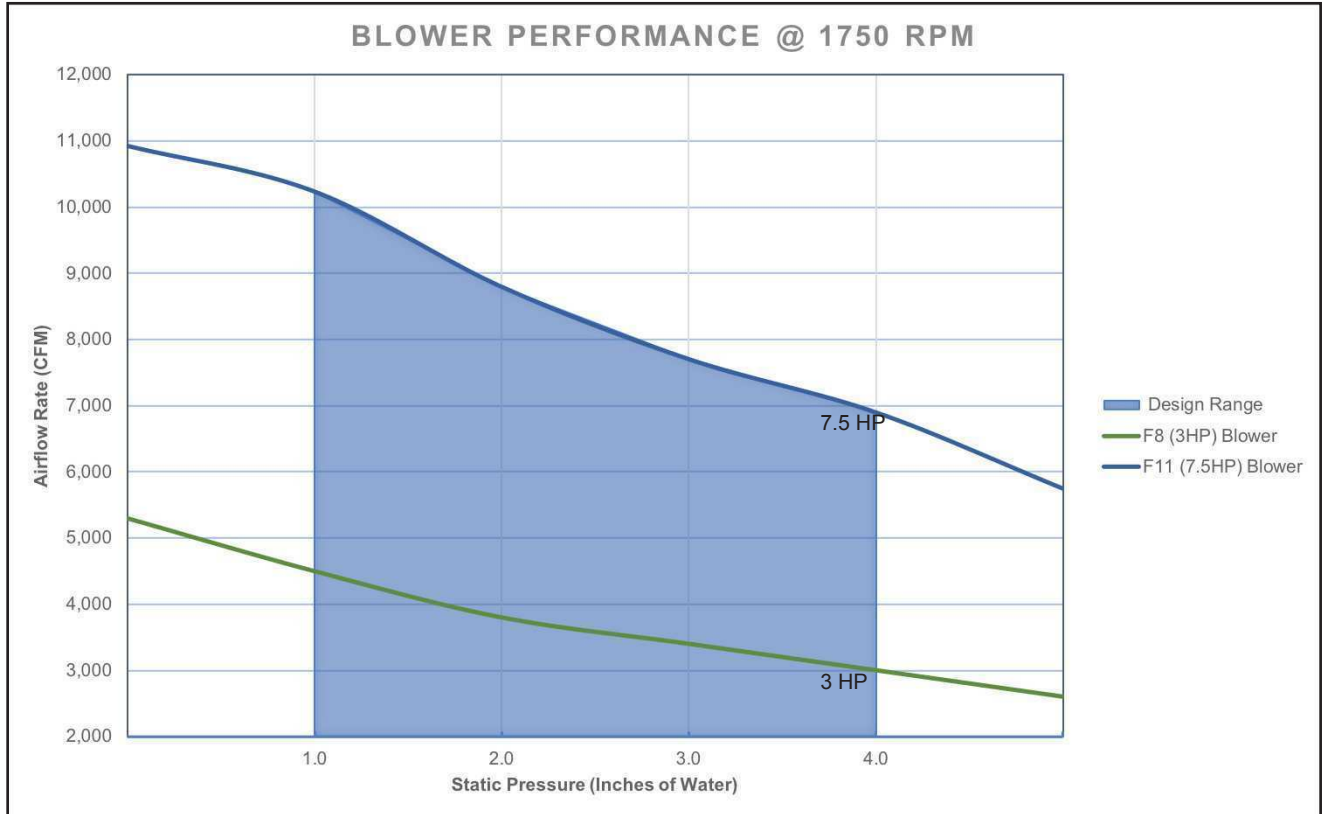

Exploded Parts Diagram

F8 BLOWER

General Notes:

ITEM	QTY	PART #	DESCRIPTION
1	1	100631	Motor, 3 HP TEFC, Wash Down Duty , Blower Fan
2	1	100632	Coupling Bushing, 1.125", Fan to 3 HP Motor Connection
3	2	100588	Coupling Flange, Fan to 7.5 HP Motor (With Bolts)
4	1	100587	Coupling Element, Fan to 7.5 HP Motor Connection
5	1	100590	Coupling Bushing, 1.5", Fan to 7.5 HP Motor Connection
6	1	100592	Bearing, 1.5", Pillow Block, Fan
7	1	100604	Shaft Blower Fan
8	1	100635	Fan Wheel Assembly, Blower
9	1	100603	Fan Wheel Hub, Blower
10	1	100615	Panel, Fan Access
11	1	100591	Bearing, 1.5", Four Bolt Flange, Fan
12	6	20012066	Filter Element
13	6	100610	Filter Intake Covers
14	4	100159	Anti-Vibration Pads
15	4	-----	Bearing Grease Spots - See Maintenance Page

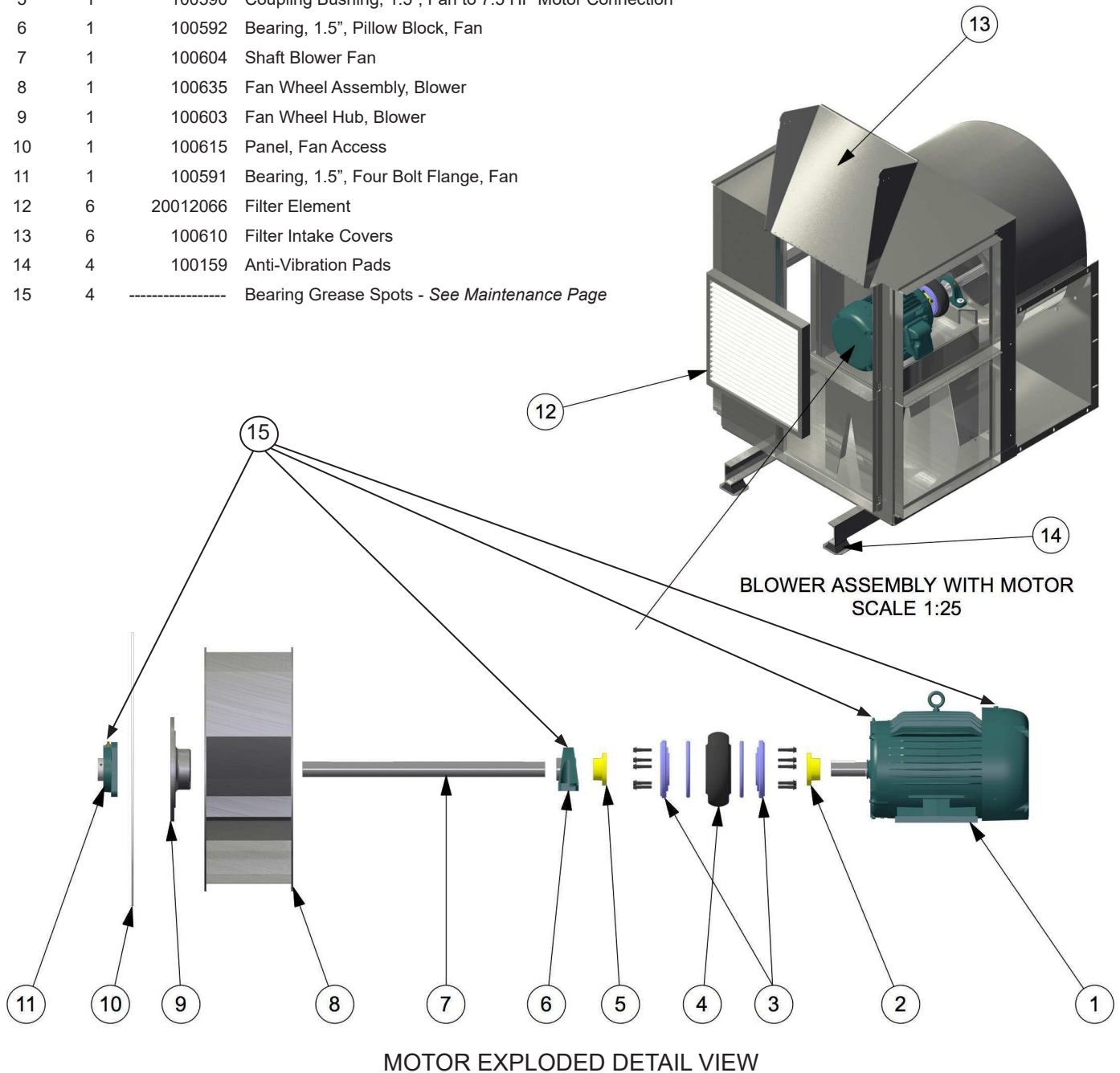

Integration



F8 and F11 BLOWER INTEGRATION

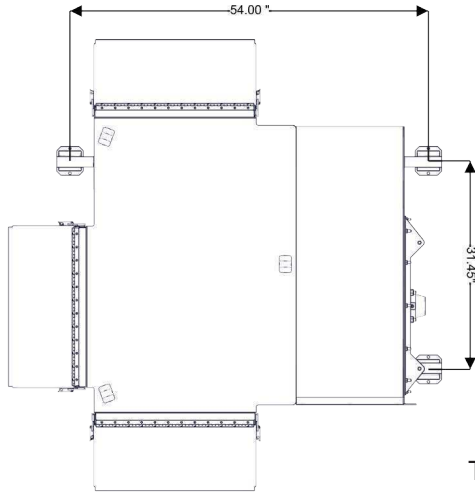

TOP VIEW

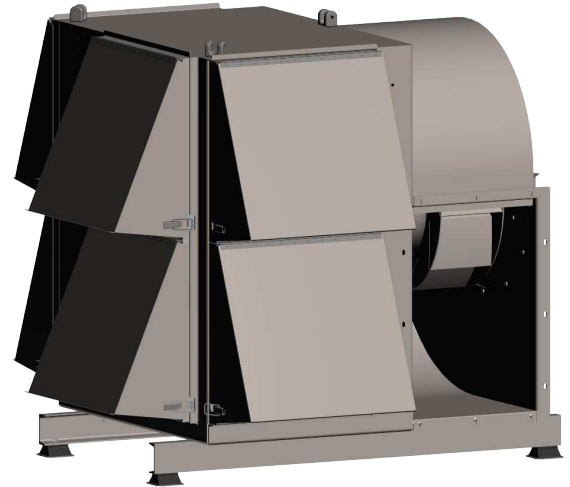

UNIT WEIGHT
1400 LBS APPROX.

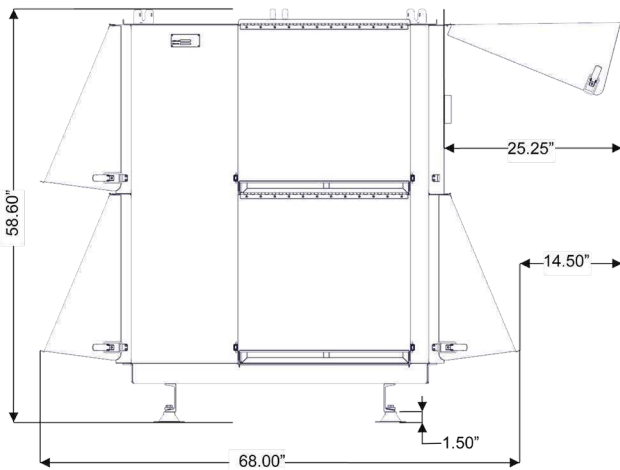

SIDE VIEW

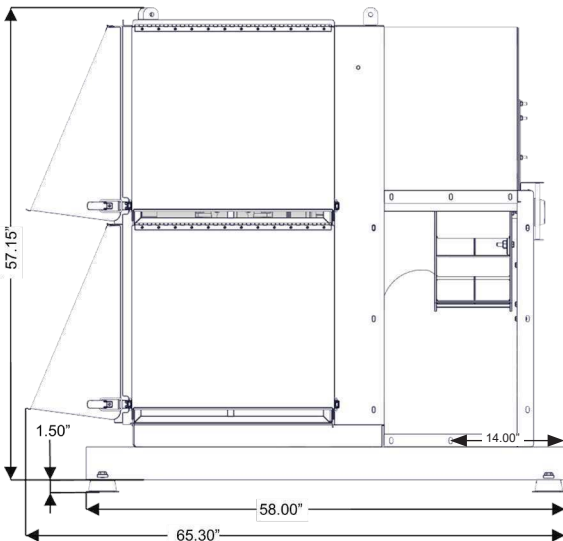

FRONT VIEW

MINIMUM EIGHT (8) ANCHORS USED

3/8" THREADED ROD WITH SIMPSON STRONG-TIE SET IN HIGH STRENGTH EPOXY AT 3" EMBEDMENT DEPTH

OR

3/8" REDHEAD CONCRETE WEDGE ANCHOR BOLTS AT 3" OR GREATER EMBEDMENT DEPTH

NOTE: 8' L x 8' W x 6" OR GREATER PAD IS GENERALLY USED.

F8 and F11 BLOWER INTEGRATION

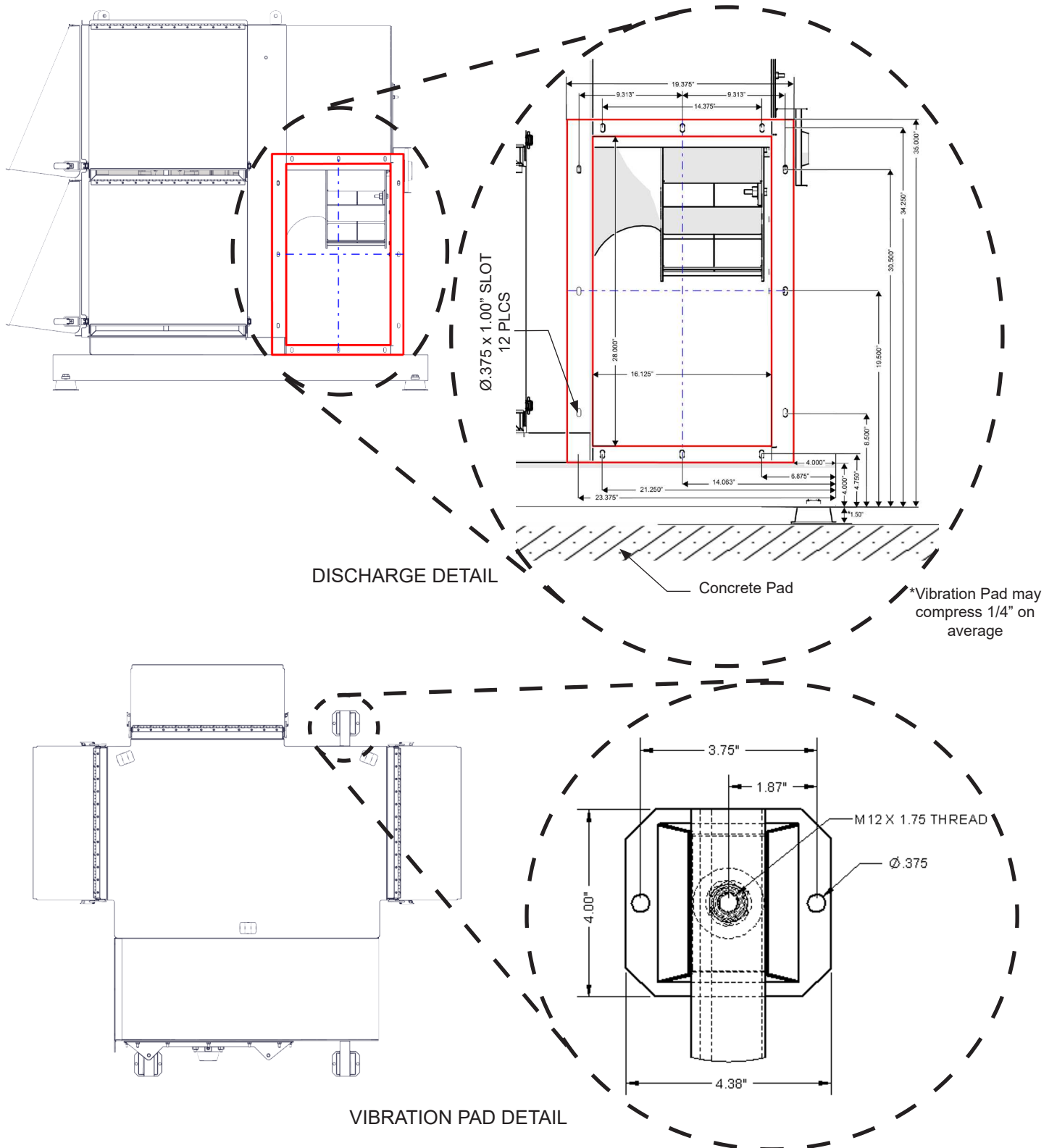

Blower Ducting

BLOWER DUCTING

F8 AND F11 BLOWER

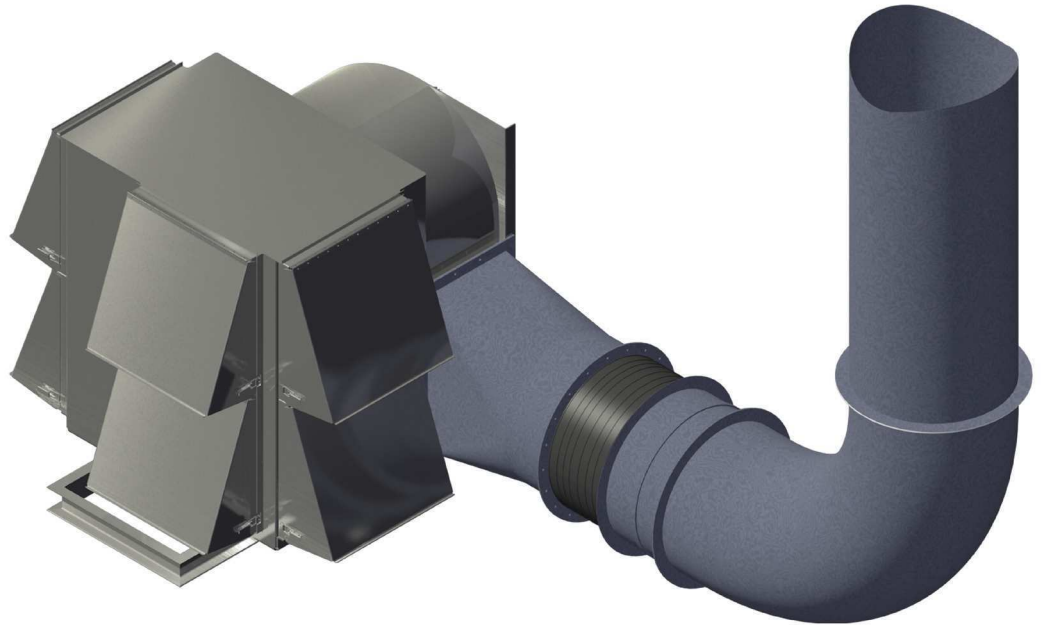

EXAMPLE OF CUSTOMER DUCTING FOR GROUND MOUNT

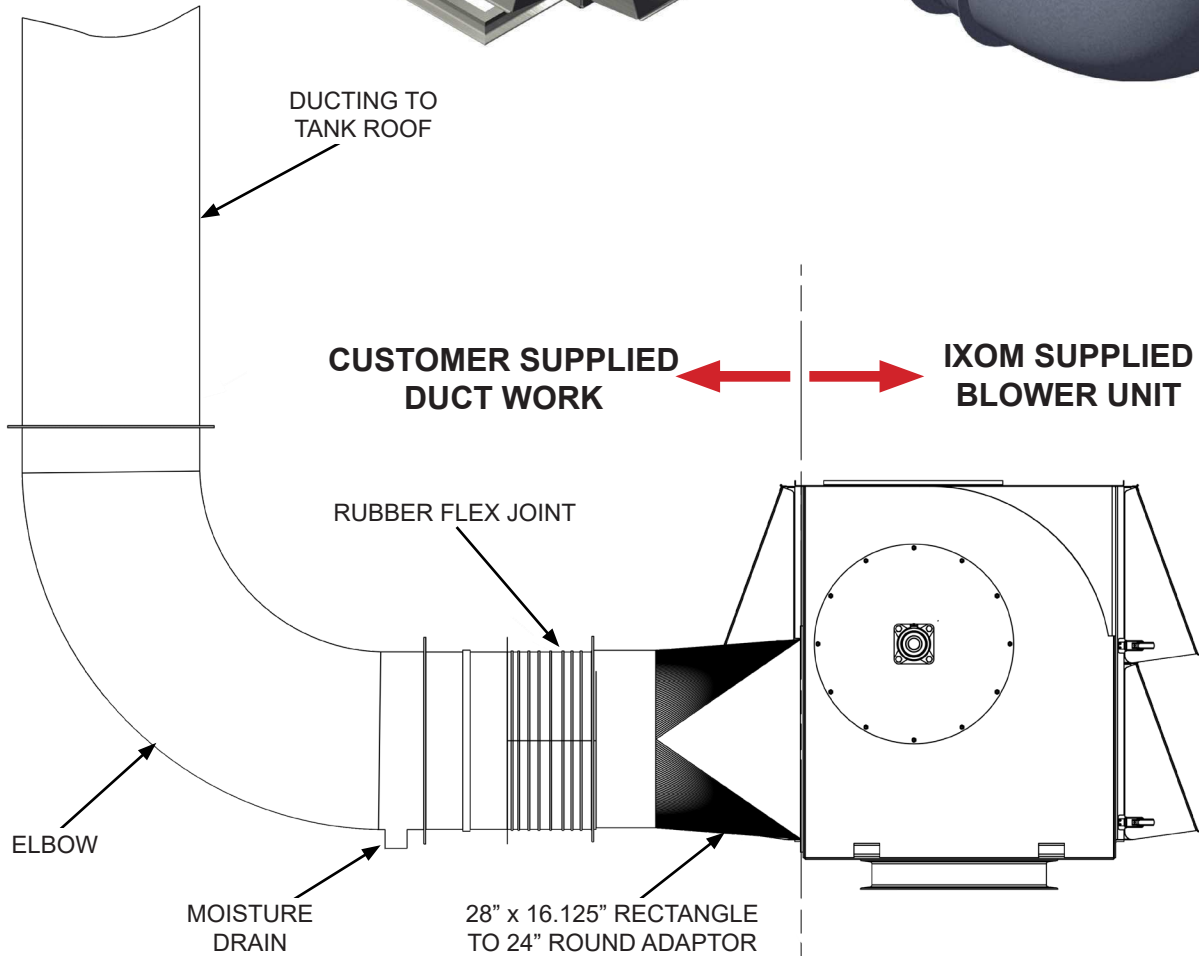

Large Ventilation Blower Startup and Operation

Wiring

Placement Checks

Before starting the Blower Unit a few checks need to be done to confirm the placement is correct.

Placement Check	Check
Is the blower properly secured to the isolation pads?	
Is the motor wired properly to match the source voltage? Follow the motor wiring diagram on the motor decals.	
Does the blower have a local disconnect capable of being locked and tagged out for proper safety precautions for blower maintenance and electrical adjustments? (i.e. checking bearings)	
Is the control panel wired correctly? (Control Panel Diagram)	
Is the blower ducting properly supported and airtight at all joints and connections?	
Is the Motor rotating the correct direction? (See Rotation Check below)	

Final Checks

Now that the install checks have been completed. Now to confirm the continuity and discontinuity and then start the Blower Unit.

Check	Reading			
	Single Phase	Three Phase		
Continuity Check (Motor Windings + Splice + Wire) Reference Wiring for Line to Line Ohms	L1:L2	L1:L2	L2:L3	L1:L3
Discontinuity Check (Power to Ground) Should be Open to Ground	L1: GND	L1: GND	L2:GND	L3:GND
Source Voltage Reading (while unit is running)	L1:2	L1:2	L2:L3	L1:L3
Amperage Reading (while unit is running) Reference Wiring Full Load / Max Load	L1	L1	L2	L3
Motor Rotational Check				
Air Flow Check				

Rotation Check

Before finalizing the placement, the motor rotation needs to be checked. With someone observing the Blower Unit, briefly turn the unit on for several seconds and observe the motor rotation, observing the motor cooling fan or blower fan wheel. As the blower slows down, observe that the drive assembly is rotating the same direction as indicated on the blower motor. If the motor direction needs to be reversed; for three-phase motors, switch L1 and L2 at the motor or blower disconnect; for single-phase motors, follow the instructions on the motor wiring decal.

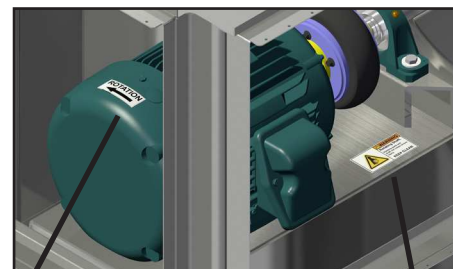

Safety and rotation labels on motor



Wiring for Ixom Blower Unit

WARNING

MOTOR MUST BE GROUNDED IN ACCORDANCE WITH THE NATIONAL ELECTRICAL CODE AND LOCAL CODE BY TRAINED PERSONNEL TO PREVENT SERIOUS ELECTRICAL SHOCKS.

TO SERVICE MOTOR, DISCONNECT POWER SOURCE FROM MOTOR AND ANY ACCESSORY DEVICES AND ALLOW MOTOR TO COME TO A COMPLETE STAND STILL.

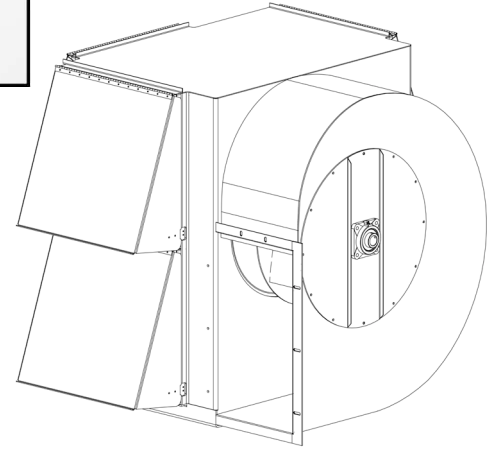
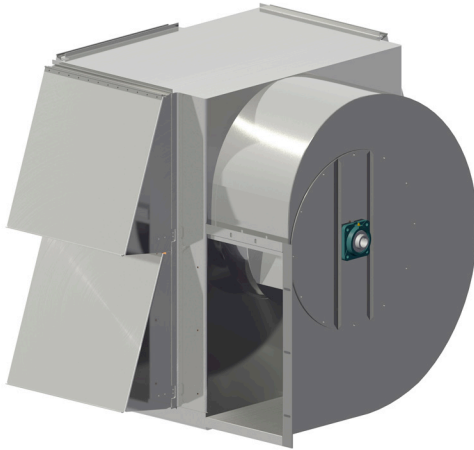

F8 BLOWER

LOW
VOLTAGE

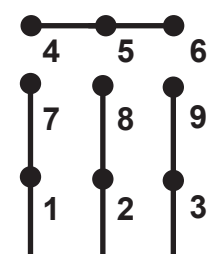

LINE

HIGH
VOLTAGE

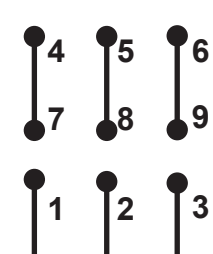

LINE

INTERCHANGE ANY TWO LINE LEADS (1-3)
TO REVERSE ROTATION.

F11 BLOWER

LOW
VOLTAGE

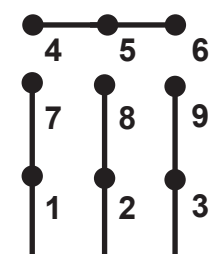

LINE

HIGH
VOLTAGE

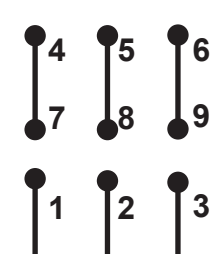

LINE

INTERCHANGE ANY TWO LINE LEADS (1-3)
TO REVERSE ROTATION.

8.4 Amps @ 208VAC / 60HZ / 3-Phase

Motor Resistance: 1.06 Ω

7.8 Amps @ 230VAC / 60HZ / 3-Phase

Motor Resistance: 1.06 Ω

3.9 Amps @ 460VAC / 60HZ / 3-Phase

Motor Resistance: 4.05 Ω

Service Factor: 1.15

19.0 Amps @ 230VAC / 60HZ / 3-Phase

Motor Resistance: 0.42 Ω

9.5 Amps @ 460VAC / 60HZ / 3-Phase

Motor Resistance: 1.52 Ω

Service Factor: 1.15

Maintenance

Large Ventilation Blower

Maintenance

Caution: Never attempt maintenance on a blower unless the electrical supply has been completely disconnected, and lockout/tagout procedures are followed. The rotating assembly may also need to be secured to eliminate the potential for wheel rotation due to other means such as wind milling or back feeding from other blowers.

General Maintenance:

Blowers must be regularly inspected, the frequency being determined by the severity of the application. Routine inspections should include the following checklist:

1. Check for wear, corrosion, and material build up on the blower wheel and/or housing and clean or replace as required.
2. Check the drive for proper alignment and lubrication.
3. Lubricate the bearings of the blower and motor. (*1/2 pump once per year*). **NEVER OVER LUBRICATE.**
4. Check for worn shaft seals and repair or replace as necessary.
5. Check all setscrews and bolts for tightness. Check isolation bases for freedom of movement, looking for broken or deteriorated rubber elements.

Bearing Maintenance:

DODGE IP and ISAF bearings are pre-packed with NLGI #2 Lithium Complex grease. For re-lubrication select a grease that is compatible with a #2 Lithium Complex grease.

High Speed Operation - in the higher speed ranges, too much grease will cause over-heating. The amount of grease that the bearing will take for a particular high speed application can only be determined by experience. **NEVER OVER LUBRICATE** The bearing has been greased at the factory and is ready to run. When establishing a relubrication schedule, note that a small amount of grease is preferable and at infrequent intervals (i.e. annually, semi-annually).

Ixom strongly cautions against over-greasing. Only personnel that understand using a very little amount of grease per application should be responsible for lubrication of the bearings on the equipment we supply. Ixom recommends only 1/2 pump grease per year.

Air Filters:

The use of any type of filter requires that it **be kept clean** to prevent excessive pressure drop in the lines.

The dry element of the filter may be cleaned with soap & water and reused.

A total of six pleated filters occupy the filter housing. It is recommended the filters be cleaned periodically, and especially leading into seasons of critical application.

Filter elements should be replaced when showing signs of wear which may be typical after several washes.

Filter element replacements should comply with the below requirements.

24" x 24" x 2" : 3,000cfm : 10 Micron : Pleated polyester.

Model: IFM P295 or Dollinger AI-187

Alternative: Graver Tech. GT-23106

Warranty



GridBee THM Removal Systems

Limited Replacement Warranty

GridBee SN Spray Units. GridBee SN Spray Units and blowers are warranted to be free of defective parts, materials, and workmanship for a period of two years from the date of purchase. The optional control panels, by other manufactures, are covered by a manufacturer's warranty of one year from date of purchase. This warranty is valid only for use of the GridBee THM Removal System in accordance with the owner's manual and any initial and ongoing factory recommendations. This warranty is limited to the repair or replacement of defective components only and does not apply to normal wear and tear. If the factory's service crews performed the original on-site placement and startup, then this warranty also includes labor. Where labor is included, in lieu of sending a factory service crew to the site for minor repairs, Ixom may choose to send the replacement parts to the owner postage-paid and may pay the owner a reasonable labor allowance, as determined solely by Ixom, to install the parts. There is no liability for consequential damages of any type. The warranty that is submitted and provided with the purchased equipment is the valid warranty.

GridBee control panels, and any optional accessories. These items are considered "buyout" items for Ixom, and as such include a warranty against defects in material and workmanship for one year from the date of purchase. This warranty covers parts only, not labor. Parts that are determined by Ixom to be defective in material or workmanship under normal use during the one year warranty period will be repaired or replaced. Shipping charges are the responsibility of the customer.

Terms applicable to all equipment. This Limited Replacement Warranty is subject to the terms of Ixom's General Terms and Conditions of Sale. In the event of any inconsistency between the terms of this Limited Replacement Warranty and Ixom's General Terms and Conditions of Sale, the terms of this Limited Replacement Warranty shall prevail to the extent of that inconsistency.

IXOM

WATERCARE

Nationwide Installation & Service

EVERYONE DESERVES GREAT CUSTOMER SUPPORT

Ixom Watercare earns customer trust with unparalleled service start to finish. Every department in Ixom is dedicated to the support of our Customers and the improvement of water quality. Complete life cycle support is much, much more than a returned phone call or an email. It centers around direct access and communication to those who can help when help is needed from the beginning of a project throughout the life of the equipment.

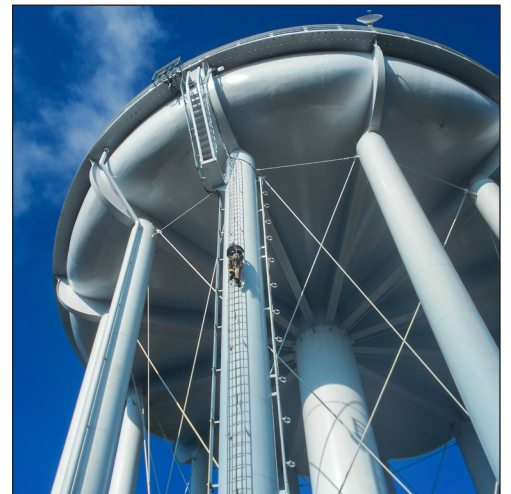

ABOUT IXOM

Ixom combines innovative water quality solutions with top notch manufacturing and nationwide in-field service capabilities to create trusted, full circle support our Customers depend on.

We design and manufacture many trusted brands including GridBee®, SolarBee®, MIEX®, and ResidualHQ® for use across the water quality spectrum. This includes solutions for Water Treatment, Distribution Treatment, Wastewater Treatment and Lakes & Source Water Reservoirs.

Ixom has thousands of installations and is an industry-leader solving water quality problems across the United States, Canada and the world.

Contact us today to discuss your water quality and service needs.

ixomwatercare.com
866-437-8076 • watercare@ixom.com