

GridBee GF1250PwC

Owner's Manual



Table of Contents



GridBee GF1250PWc Owner's Manual

Safety	1
Operation	4
Features	8
Maintenance	14
Electrical	21
Troubleshooting	23
Parts Diagram	26
Dimension Drawing	27
Appendix	28
Technical Specifications	29
Warranty	34
Service Program	35
Customer Service	36

Safety

IMPORTANT

**YOU MUST COMPLETELY
READ AND FULLY
UNDERSTAND THESE
INSTRUCTIONS BEFORE
INSTALLING, OPERATING,
OR SERVICING THIS UNIT.**

Be sure you have read all installation, operation, maintenance and safety instructions before you install, service or begin to operate this unit.

Accidents occur every year because of careless use of industrial equipment. You can avoid hazards by following these safety instructions, and applying some ordinary common sense when operating or servicing this unit.

Keep in mind that **full operator attention and alertness** are required when operating or servicing this unit.

USE COMMON SENSE!! Most accidents can be avoided by using **common sense and concentration** on the job being done.



Carefully read safety information when you see any safety symbols.



Safety

IMPORTANT

YOU MUST COMPLETELY READ AND FULLY UNDERSTAND THESE INSTRUCTIONS BEFORE INSTALLING, OPERATING, OR SERVICING THIS UNIT.

Identify all possible hazards. Determine what safeguards are needed and implement them. **Only you, the user,** understand your product and system characteristics fully. *The ultimate responsibility for safety is with you. Your safety ultimately rests in your hands.* Do your part and you will enjoy safe, trouble free operation for years to come. This instruction manual is not intended to include a comprehensive listing of all details for all procedures required for placement, operation and maintenance. If you have a question about a procedure or are uncertain about any detail, **Do Not Proceed.** Please contact Ixom Watercare Customer Service at **866-437-8076** to speak to a representative.



IMPORTANT!!!

Follow all federal and state laws in regards to safety regulations of working at heights, confined spaces, rescue, etc. as required by the U.S. Department of Labor, Occupational Safety and Health Administration. Use necessary PPE when placing and servicing this unit.



Thin Ice Hazard

WARNING: ICE SURROUNDING MACHINE MAY NOT SUPPORT WEIGHT, KEEP CLEAR OF THIN ICE.



ELECTRICAL HAZARD

WARNING: THIS EQUIPMENT CONTAINS HIGH VOLTAGE! ELECTRICAL SHOCK CAN CAUSE SERIOUS OR FATAL INJURY. ONLY QUALIFIED PERSONNEL SHOULD ATTEMPT PLACEMENT, OPERATION AND MAINTENANCE OF ELECTRICAL EQUIPMENT. REMOVE ALL SOURCES OF ELECTRICAL POWER BEFORE PERFORMING ANY SERVICE WORK TO THE MACHINE. USE PROPER LOCKOUT TAGOUT (LOTO) PROCEDURES TO ENSURE A SAFE WORK ENVIRONMENT.



Crush Hazard

WARNING: DO NOT REMOVE ANY FLOAT ASSEMBLY BOLTS OR PINS WHILE EQUIPMENT IS FLOATING IN WATER. EQUIPMENT MUST BE SECURELY SUPPORTED BEFORE PERFORMING SERVICE.



Rotating Hazard

CAUTION: KEEP BODY APPENANDAGES OR LOOSE CLOTHING AWAY FROM EQUIPMENT WHILE OPERATING. ENSURE EQUIPMENT IS OFF BEFORE ATTEMPTING SERVICE.



Entanglement Hazard

WARNING: ENSURE THAT PERSONNEL ARE CLEAR OF THE ELECTRIC CORD AND CHAIN TO AVOID ENTANGLEMENT.



Laceration Hazard

CAUTION: EDGES MAY BE SHARP AND CAUSE LACERATION IF PROPER CARE IS NOT USED.

Safety

Protect Yourself

It is important that you comply with all relative OSHA and local regulations while installing and performing any maintenance to the mixer circulation equipment.

Key OSHA Compliance Standards that must be followed (and not limited to) are:

- **1910.146 Permit-required confined spaces**
- **1910.147 Lockout/Tagout**
- **1926.500 Fall Protection**

Fall Protection Tips

- Identify all potential tripping and fall hazards before work starts.
- Look for fall hazards such as unprotected floor openings/edges, shafts, open hatches, stairwells, and roof openings/edges.
- Inspect fall protection and rescue equipment for defects before use.
- Select, wear, and use fall protection and rescue equipment appropriate for the task.
- Secure and stabilize all ladders before climbing.
- Never stand on the top rung/step of a ladder.
- Use handrails when you go up or down stairs.
- Practice good housekeeping. Keep cords, welding leads and air hoses out of walkways or adjacent work areas.

Refer to 29 CFR 1926.500 for complete regulations set by OSHA. Refer to your state's regulations if your state established and operates their own safety and health programs approved by OSHA.

Lockout Tagout

When the On/Off switch is in the "ON" position, the mixer may start up at any time if not already operating. The mixer's On/Off switch can be locked out by placing a pad lock thru the door latch of the controller after the switch has been turned to the "OFF" position. The On/Off switch is to be used as the emergency stop.



Permit-Required Confined Spaces

A confined space has limited openings for entry or exit, is large enough for entering and working, and is not designed for continuous worker occupancy. Confined spaces include underground reservoirs, ground storage tanks, elevated tanks, silos, manholes, and pipelines.

Confined Space Tips

- Do not enter permit-required confined spaces without being trained and without having a permit to enter.
- Review, understand and follow employer's procedures before entering permit-required confined spaces and know how and when to exit.
- Before entry, identify any physical hazards.
- Before and during entry, test and monitor for oxygen content, flammability, toxicity or explosive hazards as necessary.
- Use fall protection, rescue, air monitoring, ventilation, lighting and communication equipment according to entry procedures.
- Maintain contact at all times with a trained attendant either visually, via phone, or by two-way radio. This monitoring system enables the attendant and entry supervisor to order you to evacuate and to alert appropriately trained rescue personnel to rescue entrants when needed.

Refer to 29 CFR 1910.146 for complete regulations set by OSHA. Refer to your state's regulations if your state established and operates their own safety and health programs approved by OSHA.

Operation

Operation

GF Series

The GridBee is designed to circulate water by bringing water from below and sending it out across the top in a thin layer causing a mixing effect. The laminar layer flows outward radially, in diverging “stream lines” from the distribution dish. As it does, vertical flow is induced in between the water being drawn below and the water above. At the level of the flow intake, water is drawn from all corners of the pond. As this lower layer of fluid makes its way inward with converging streamlines to the GridBee, the water is forced upward, toward the surface, providing gentle mixing, de-stratification, and surface renewal.

The GF series GridBee requires a minimal amount of AC grid-power. The grid provides power to the onboard AC:DC power box and motor controller that drive the brushless motor. The GF Technology allows the GridBee to operate during day and night while drawing minimal amount of power from the grid.

During operation, a visible flow can be observed coming off the distribution dish and spreading outward. The motor and impeller is designed to operate at the same full speed as the solar-powered SolarBee models.

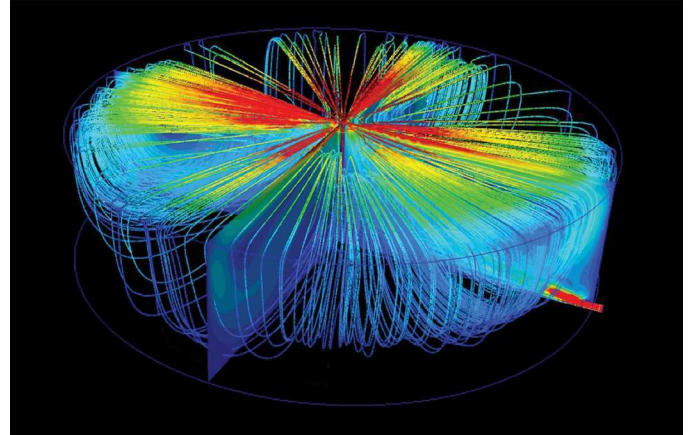

GridBee Flow Pattern



Flow Coming Off Distribution Dish

Small Frame Assembly

SB/GF1250PWc

SB/GF1250PWc Assembly

Assembly Diagram

IMPORTANT! The following pages give detailed instructions on how to assemble different portions of the machine; however, the order in which the components are assembled and entered into the reservoir may need to be altered based on the hatch size and whether the reservoir will be full or empty. For instance, the hose assembly to the base of the machine can be performed on the reservoir exterior prior to lowering the equipment inside if the hatch has a clear opening of **at least 24 inch diameter (60cm)**. A hatch this size or larger will allow the collapsible unit assembly to be installed without float disassembly required. For smaller hatches, the collapsible unit assembly will need to be broken down into multiple components and the hose assembly will need to be performed inside the reservoir. The following order of operations listed is based on a wet installation and small hatch opening.

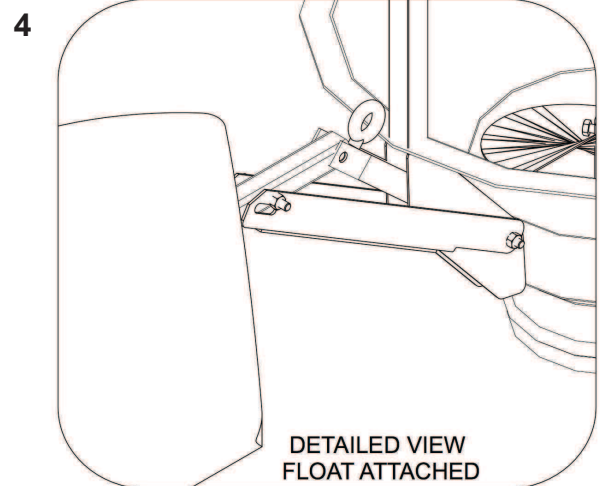
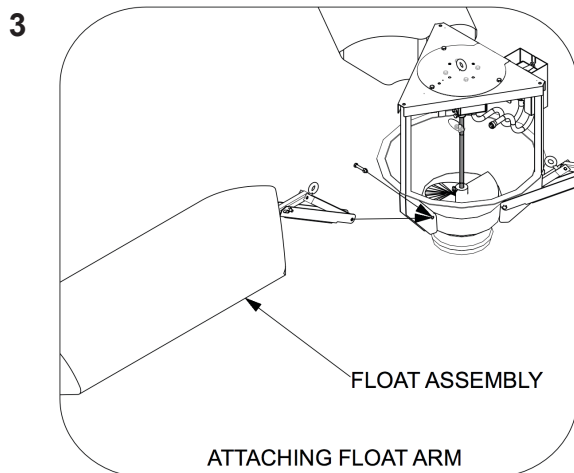
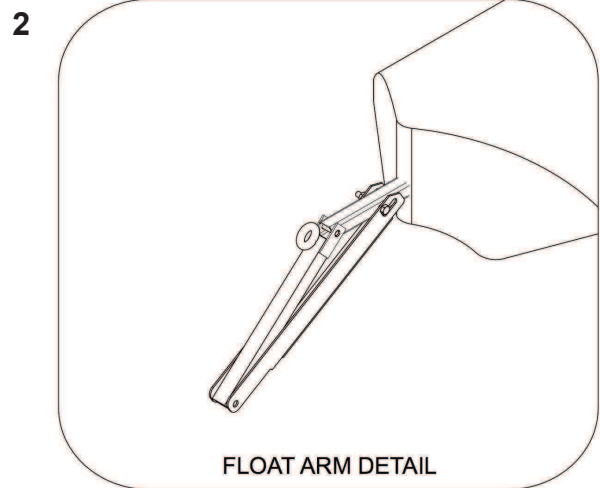
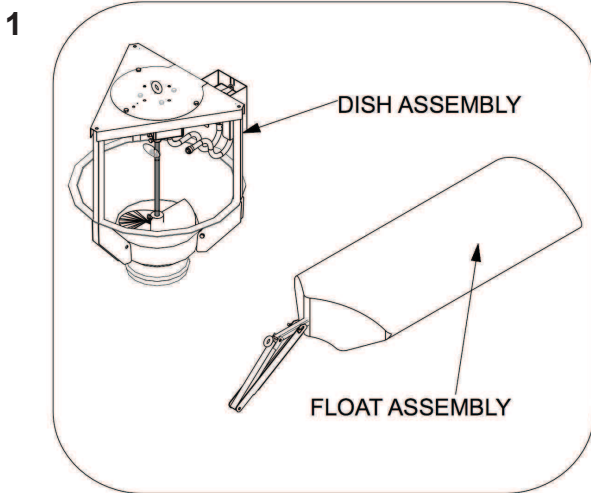

STEP 1: Locate the Dish Assembly and Float Arm Assembly. (See *Figure 1 & 2*)

STEP 2: Attach the Float Arm Assembly to the Dish Assembly with provided bolts and nylock nuts. (See *Figure 3 & 4*)

STEP 3: Repeat STEPS 1 and 2 for the other two floats.

Small Frame Assembly

SB/GF1250PWc

SB/GF1250PWc Assembly

Assembly Diagram

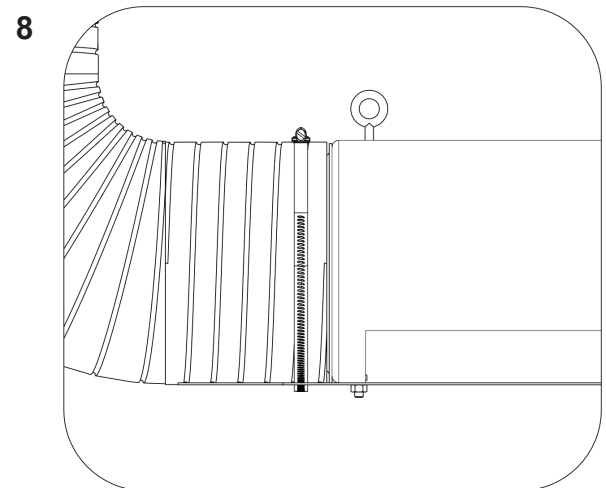
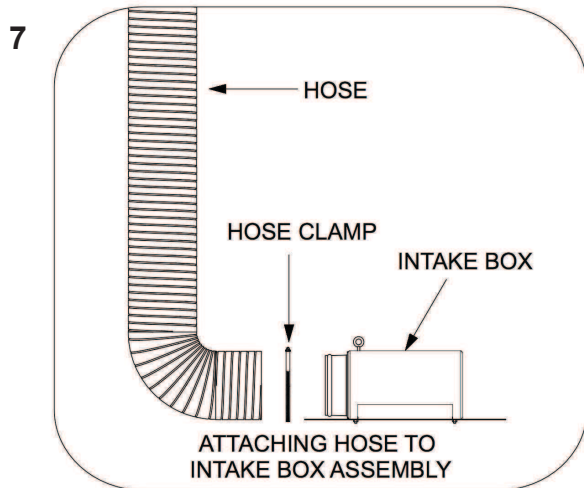
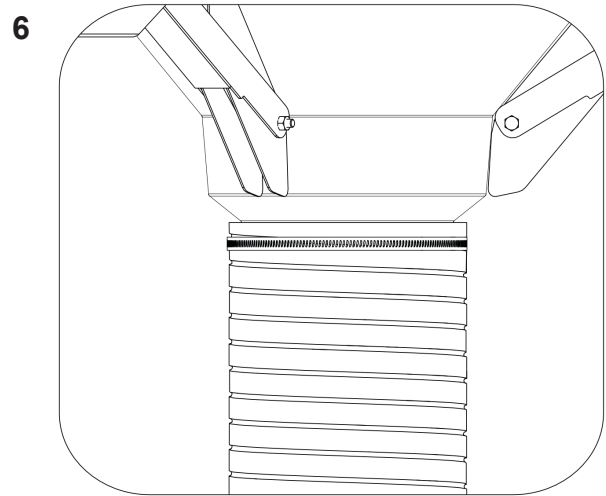
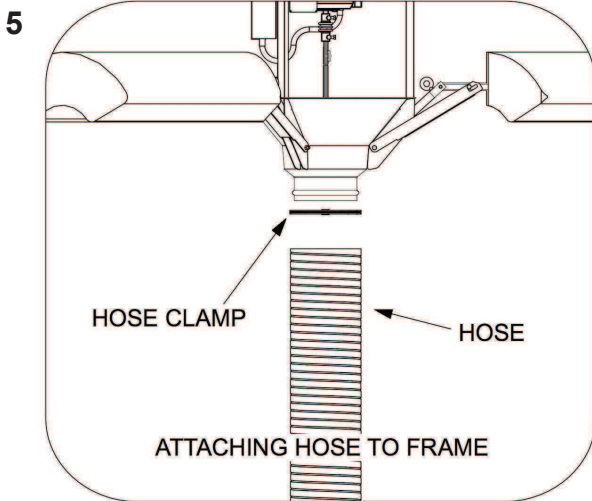

STEP 1: Locate one end of the hose section and place hose clamp over the end. Be sure that hose and clamp are installed above the metal rib of the flange and then tighten hose clamp as tight as possible to firmly secure hose. **(See Figure 5)**

STEP 2: Fasten Hose to bottom of machine by pushing hose up and all the way up above metal rib. **(See Figure 6)**

STEP 3: On the other end of the hose place the other hose clamp over the end. Fasten hose to the intake box past the metal rib of the flange and tighten hose clamp to firmly secure hose. **(See Figure 7 & 8)**

Small Frame Assembly

SB/GF1250PWc

SB/GF1250PWc Assembly

Assembly Diagram

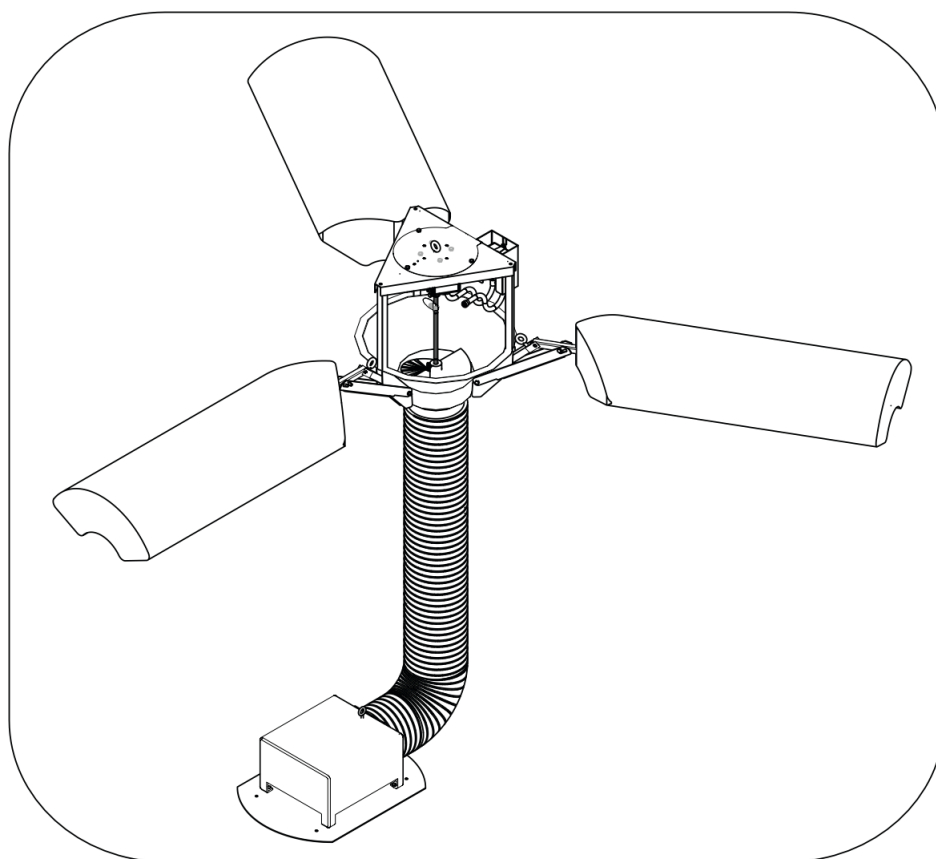

MACHINE FULLY ASSEMBLED

Features

Features

GF1250PWc

The GridBee utilizes high efficient brushless motor technology which enhance its performance through more efficient and durable components, as well as easy component access, and a more robust frame structure.

Electronics

Electrical Control Box - The electrical control box is located on the exterior of the tank / reservoir. The electrical control box converts 110VAC power to a clean 45VDC power source which then operates the motor controller. The control box also consists of a ground fault interrupter (GFI) switch to aid in protection of faulty circuits or shorting of circuits. A durable 316SS Cord Grip is used to handle all weather elements, protecting the penetration of the electrical cable to the motor controller on the inside of the tank.

Motor Controller - The motor controller is located near the motor just below the top plate of the GridBee. The motor controller is sealed in line with the electrical cord that runs to the brushless motor.

The motor controller on the GridBee receives power from the electronic control box located on the exterior of the tank. This power is delivered as 45VDC which is used to operate the brushless motor at the commanded speed.

Due to the high frequency of communication between the motor controller and brushless motor, the two components need to be located close to one another. This is the primary reason for having the motor controller located directly on the GridBee.



Electronic Control Box of an Underground Reservoir

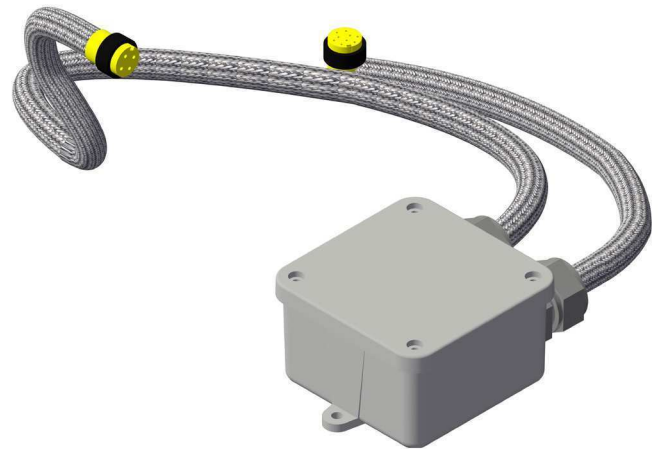

Motor Control Cord

Features

Features

GF1250PWc

All electronic connections on the GridBee equipment should only be used for the inputs or outputs that they are labeled and designed for. If any of the leads going into the electronic controller are disconnected, be sure when re-connecting to place them in the proper position.

Wiring - All electric wiring includes corrosion-resistant, industrial cords with molded, weather and watertight connectors. The connectors are indexed to prevent improper wiring. A general electrical schematic can be found in the Maintenance and Field Adjustment section.

Brushless Motor - The brushless motor is located directly below the Top Deck. 4 bolts run down through the Top Deck and into the housing of the brushless motor fastening it onto the machine.

The brushless motor is built to be very durable. The housing is constructed of casted aluminum. The brushless motor runs very quietly and smoothly. It does not require any maintenance. A drive shaft extends through the bottom center of the housing.

Shaft Coupling - The shaft coupling connects the brushless motor drive shaft to the impeller shaft. The shaft coupling is located directly below the brushless motor.

The rotating assembly (motor, shaft coupling, impeller shaft, impeller) can be removed from the machine without disconnecting the shaft coupling.

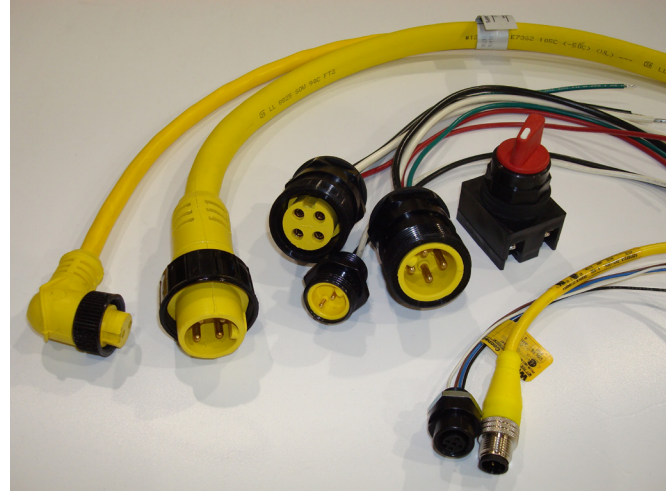

Durable Wiring And Connectors

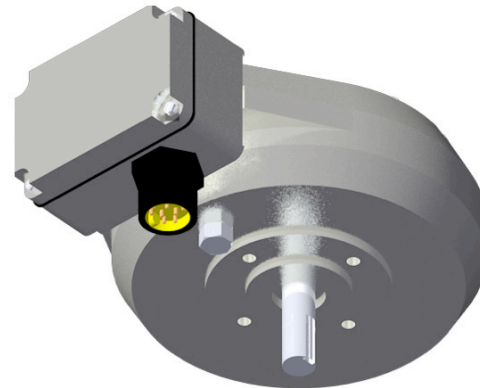

Brushless Motor

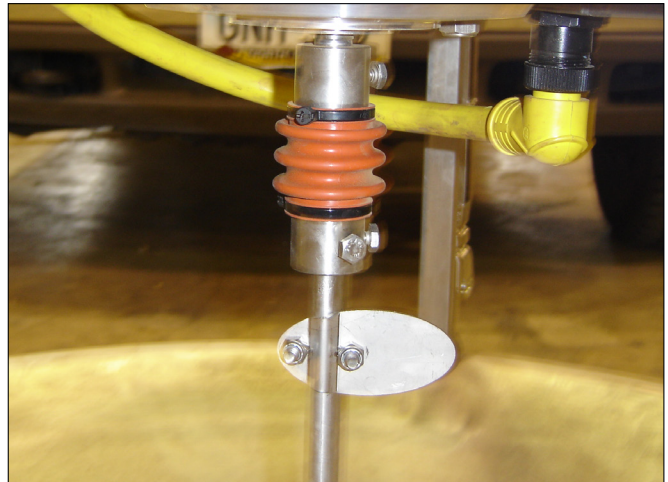

Brushless Motor With Shaft Coupling Attached

Features

Features

GF1250PWc

Impeller Assembly - The rotating assembly is made up of the stainless steel impeller shaft, stainless steel flag indicator, and stainless steel impeller blades. The impeller assembly can be removed by pulling 3 hair pins on the top plate.



CAUTION: KEEP BODY APPENDAGES OR LOOSE CLOTHING AWAY FROM THE IMPELLER ASSEMBLY WHILE THE MACHINE IS OPERATING! IF MAINTENANCE IS REQUIRED, BE SURE TO TURN THE GridBee OFF FIRST!

The flag indicator is fixed to the shaft and used as a visual indicator of the impeller shaft's rotational speed.

A food grade oil-filled, Teflon freeze sleeve secured with o-rings surrounds the impeller shaft. The freeze sleeve is free to rotate on the shaft. If the water should freeze around the machine, the freeze sleeve will stand still, frozen in by the ice, but inside the plastic sleeve, the impeller shaft will be turning.

The impeller blades are welded to a hub that is fastened to the impeller shaft. The impeller is designed to gently pump water from below and can handle up to (3-inch) 7.6cm spherical solids.

The impeller bushing is a smooth collar that the impeller shaft tip fits into. The impeller bushing aligns and centers the impeller shaft within the machine.



Turn GridBee Off Before Performing Maintenance

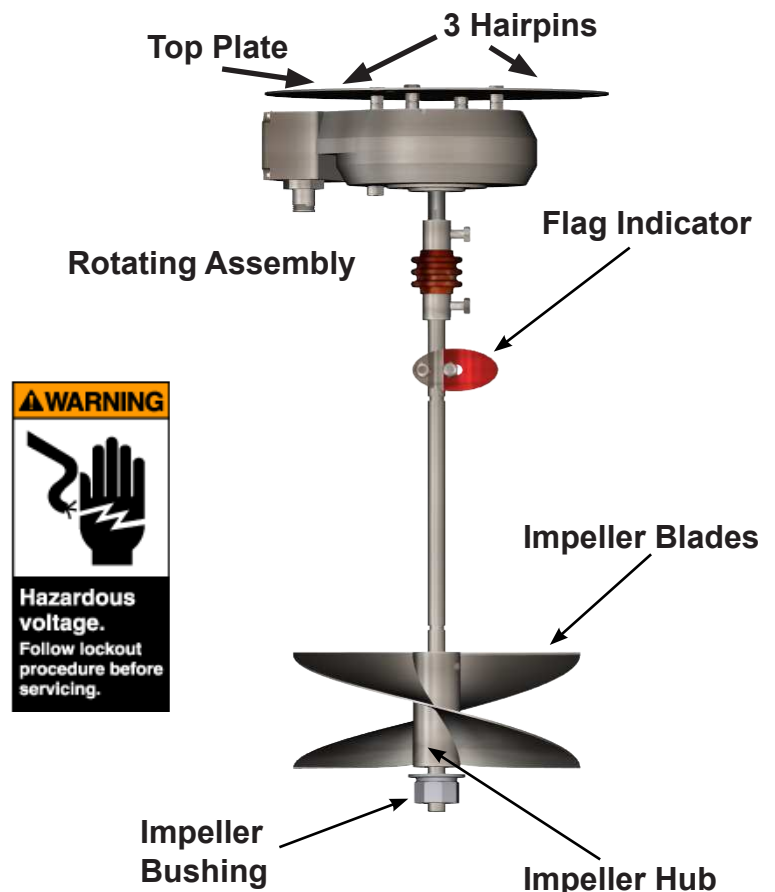

Features

Features

GF1250PWc

Distributor Dish / Hose / Intake Plate

The distributor dish, structural members, structural fasteners, and mounting brackets are constructed of stainless steel.

Distributor Dish - Near-laminar flow is achieved by the GridBee due to its uniquely designed distributor dish. The impeller rotates while sitting within the lower half of the distributor dish. The gentle water movement strengthens the induced flow effect (water movement occurring between the lower water layer entering the machine and the upper water layer leaving the dish).

The top lip of the distributor dish is set approximately 3/4- inch to 1-inch (2.0cm - 2.5 cm) below the surface of the water to achieve best flow results. The distributor dish depth is set at the factory and should not need adjustment after deployment.

Hose / Intake - The hose extends from below the dish down to the floor of the reservoir. The intake level is generally set just above the floor of the reservoir. As the water level fluctuates, the intake remains at a fixed level above the reservoir bottom as the extra hose lays on the bottom. The intake draws water horizontally into the hose.

The contact between the intake and the floor prevents the machine from rotating or moving out of place. The machine naturally has a very small torque due to impeller rotation.

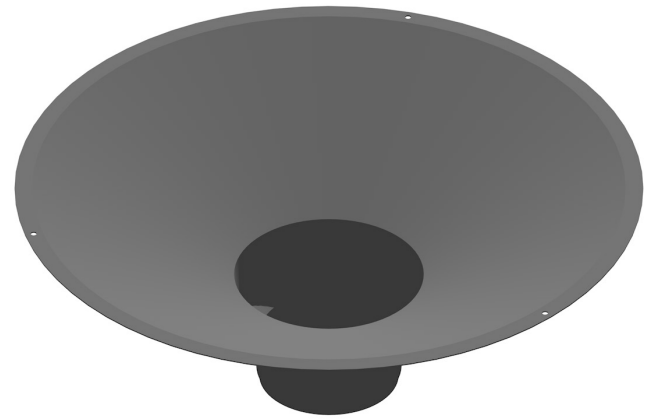

Distributor Dish

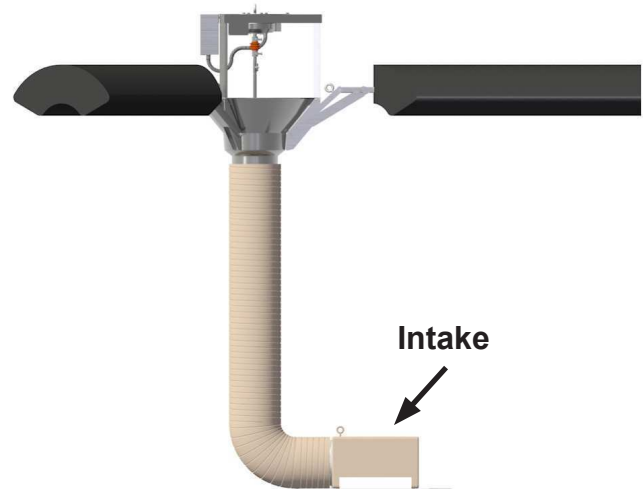

Hose With Bend Keeping Intake Stationary

Features

Features

GF1250PWc

Release Channel / Floats

The GridBee contains 3 release channels and 3 floats. The release channels allow vertical positioning of the machine and the floats provide buoyancy.

Floats - The float is made from high density Polyethylene. The floats are filled with a Polystyrene closed-cell foam for long term buoyancy. The stainless steel float tube is molded into the float. The float tube connects the float to the release channel and release tube. The float is shaped to hug the hose for installation purposes allowing the machine to be installed in a 24" square hatch. The floats have a uniquely designed shape to:

- Minimize space when collapsed around the hose.
- Minimize the interference with the water flow on the surface coming off the distributor dish.

Release Tube - The release tubes are constructed of stainless steel. They directly connect the floats to the central machine structure.



Float



Collapsed Float

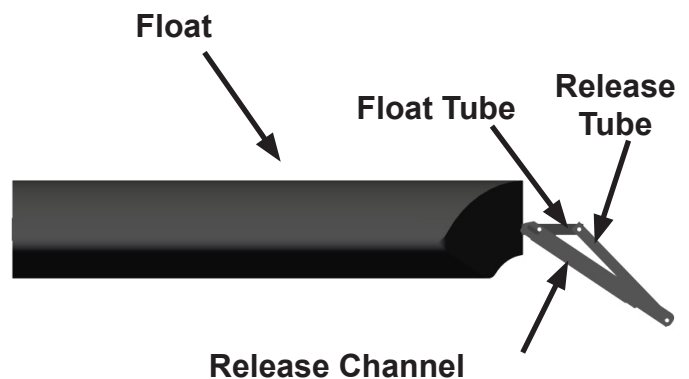

Features

Features

GF1250PWc

Float Assembly - The float assembly connects to the core unit in one location. There is no adjustment necessary for setting the dish depth.

The float assembly is bolted to the core unit of the GridBee to allow the distributor dish lip to be automatically set to the correct depth below the surface of the water. The depth may vary depending on hose length being supported by the machine and the amount of hose resting on the bottom of the reservoir due to fluctuations of the water.

Each float tube is connected to the central machine structure with 1 bolt. Each float is connected to the float tube by one pin. Each float assembly is constructed of the molded float and float tube. The end of the float tube contacts the core unit frame when the float is extended into place by means of buoyancy pressure when deployed into the water.

If the machine is resting in the bottom of an empty tank, the GridBee will be supported against the floats resting on the floor of the tank. Once water is brought back into the tank, the machine will self deploy and begin to float.

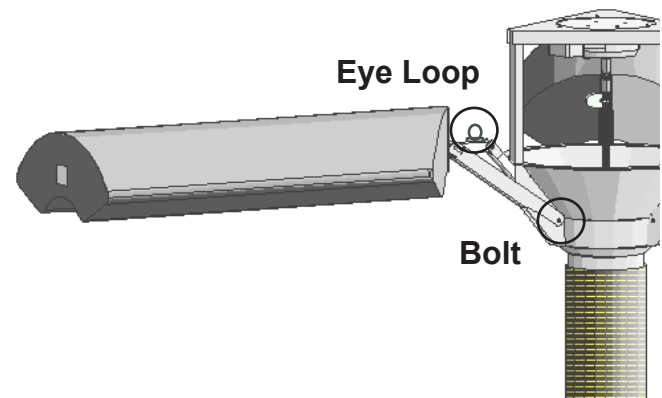
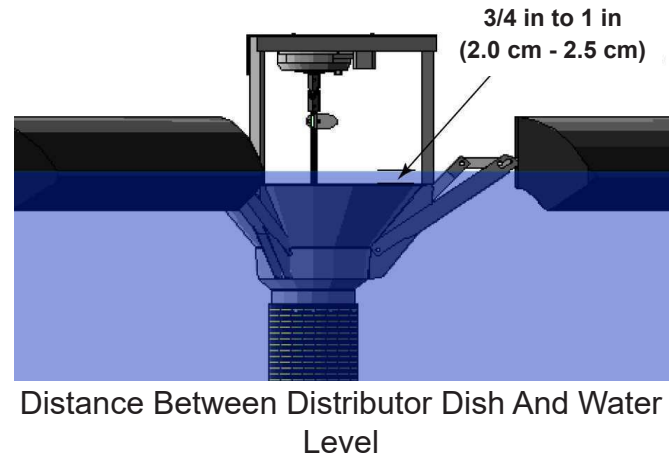

CAUTION: DO NOT REMOVE ANY FLOAT ASSEMBLY PINS OR BOLTS WHILE THE GridBee IS FLOATING IN THE WATER! THE GridBee MUST BE RESTING ON THE GROUND OR SAFELY SUPPORTED TO RELIEVE THE FORCES ON THE FLOAT ASSEMBLY STRUCTURES PRIOR TO DISASSEMBLY! FAILURE TO FOLLOW THIS WARNING COULD LEAD TO SINKING THE GridBee, SERIOUS INJURY!

Maintenance

Maintenance and Field Adjustment

SB / GF PW Series Mixers

The performance of the Machine has proven to increase tremendously when its operator understands the operation of the machine and knows how to carry out field adjustment procedures.

In most cases, the operator have can perform routine checkups and field adjustment procedures on the Machine, by pulling the Machine to the hatch. A large, expensive boat isn't necessary. When tank entry is required, an inflatable raft/boat (approximately 6 ft) is deployed inside the tank.

It is extremely important that safety comes first every time the Machine is inspected or having maintenance procedures performed. It is strongly encouraged that anyone working on or near the machine follow these rules:



⚠️ Wear a personal floatation device

⚠️ Stay focused and alert

⚠️ Turn the Machine off before working on it

⚠️ Stay clear of parts while they are moving

To turn the Machine motor off, turn the On / Off switch to the off position. To completely power down the digital controller, remove all power sources in the proper sequence.

SAFETY FIRST

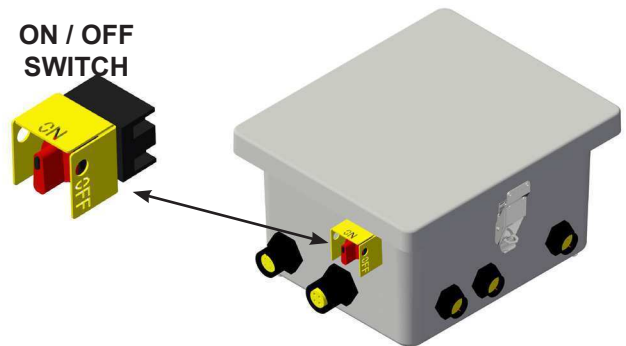

**DIGITAL
CONTROLLER**

Maintenance

Rigging Points

SB / GF Series Small Frame Mixers

Under some circumstances, it may be necessary for the customer to remove or transport the machine from the reservoir. For potable water applications, Ixom strongly encourages the customer to consult with our Customer Support Team before attempting to remove a potable water machine. The machine is designed to be suspended by three points that are reinforced.

Rigging may need to be made up to allow connection to all three rigging points. The design calls for all three points to be used in order to support the weight of the machine and keep it balanced once suspended.

MODEL MAY VARY

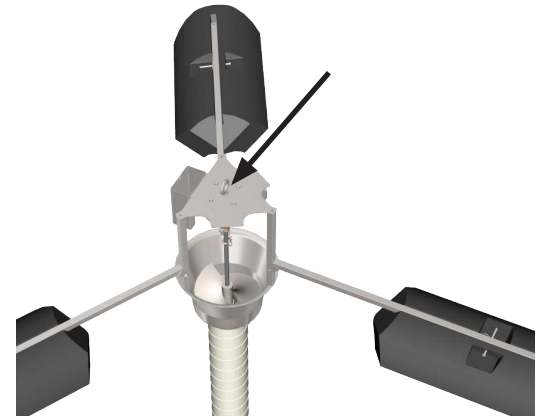

500PWc



1250PWc

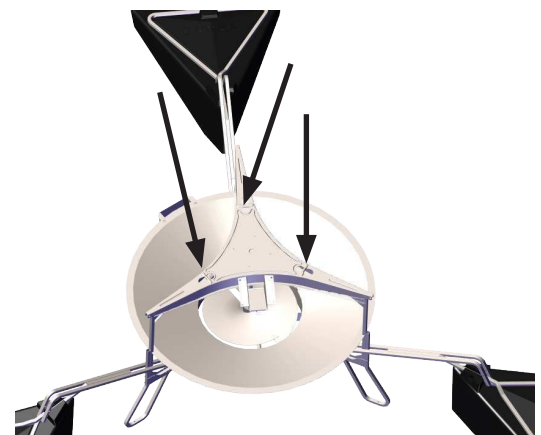

Large Frame Machines



CAUTION: DO NOT REMOVE ANY FLOAT ASSEMBLY PINS OR BOLTS WHILE THE MACHINE IS FLOATING IN THE WATER! THE MACHINE MUST BE RESTING ON THE GROUND OR SAFELY SUPPORTED TO RELIEVE THE FORCES ON THE FLOAT ASSEMBLY STRUCTURES PRIOR TO DISASSEMBLY! FAILURE TO FOLLOW THIS WARNING COULD LEAD TO SINKING THE MACHINE, OR CAUSE SERIOUS INJURY!



Maintenance

Small Frame Dish Levels

SB / GF Series Small Frame Mixers

Distribution Dish Level Setting

The machine distributor dish depth in the water is a key factor in maintaining the near-laminar flow of water coming off the machine.

The distribution dish level setting is measured from the top lip of the dish up to the water surface. For the Small Frame machine, set the depth level according to the following table:

Model	Depth - Inch	Depth - cm
500PWc	1 1/2 - 2	3.8 - 5.0
1250PWc	3/4 - 1	2.0 - 2.5

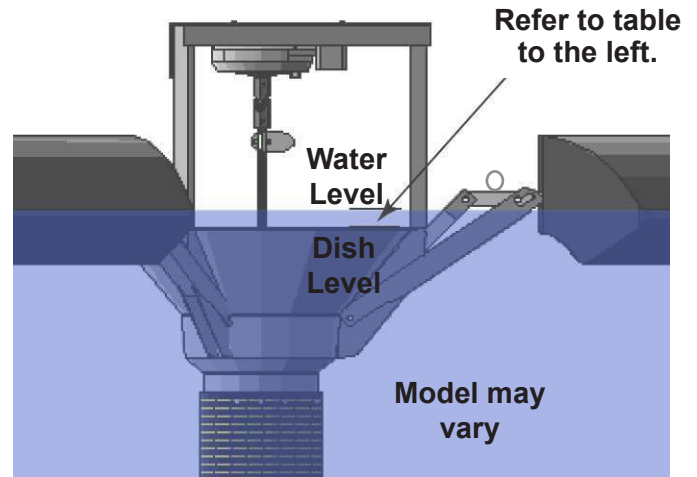

Distance Between Distributor Dish And Water Level

Distribution Dish Level Adjustment

TOOLS RECOMMENDED:

No tools are necessary.

The collapsible machine model was designed specially for potable tanks and reservoirs where the hatch size is too small for confined space entry. Therefore, the float assembly were designed to set the machine in the correct depth of water when the machine is deployed.

There are no adjustments that needed for setting the dish depth. After the reservoir has been drained and refilled, the machine will automatically redeploy itself. It is a good idea to visually check the machine to confirm that the machine had properly deployed itself in the case of the tank being drained and refilled.

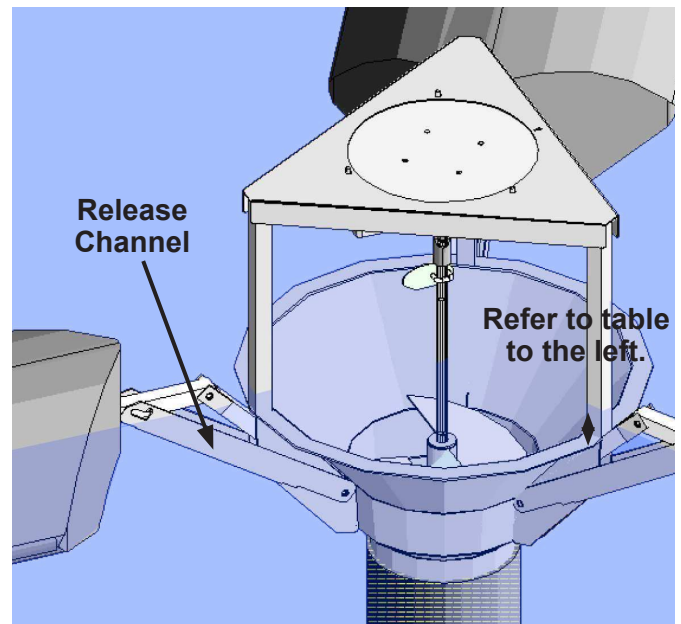

Water Level Refer to table upper left.

Maintenance

RPM Check

SB/GF Series

Impeller Rotational Speed Check

During clear skies and good sunlight weather conditions, the drive system of the unit should operate:

- 1) At a rotational speed between 55 and 85 revolutions per minute (rpm).
- 2) In a clockwise direction when looking down at the impeller.

Checking Rotational Speed

TOOLS RECOMMENDED:

Watch or Stopwatch

STEP 1: Locate the flag indicator on the impeller shaft.

STEP 2: Start the stopwatch or mark a starting point on the watch. Immediately begin counting each full revolution of the flag indicator (starting with "ZERO", "ONE", "TWO", etc) for a time of less than or equal to 1 minute and at least 20 seconds. This step is easier with two people, one counting revolutions and the other keeping track of the time expired.

STEP 3: Quit counting revolutions and immediately observe how much time has expired in seconds.

STEP 4: Use the following equation to calculate rotational speed in rpms:

$$\text{Revolutions Per Minute (RPM)} = \frac{(\# \text{ Revolutions Counted} \times 60)}{\# \text{ Seconds Expired}}$$

MODEL MAY VARY

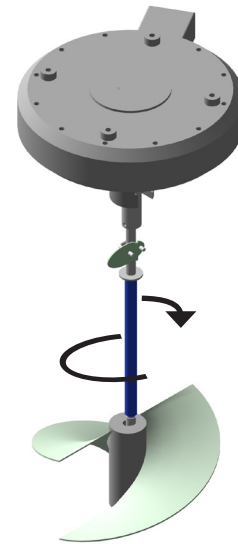

Clockwise Rotation When Looking Down

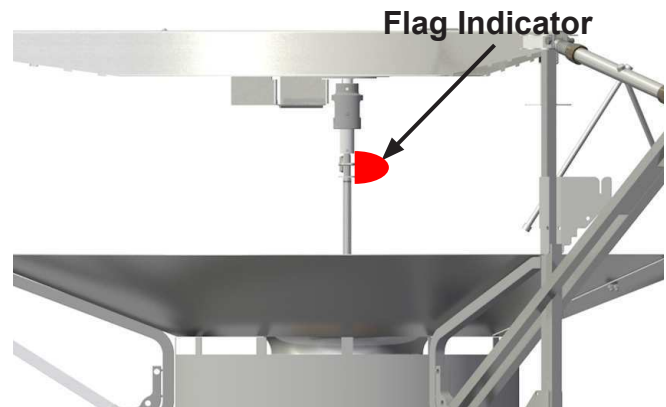

Flag Indicator Section of Impeller Shaft

Example: 30 Revolutions were counted in a time period of 30 seconds.

$$\text{RPM} = (30 \text{ revolutions} \times 60) / (30 \text{ seconds}) = 60$$

Impeller Rotational Speed = 60 RPMs

Maintenance

Impeller Assembly Removal

SB / GF Series Small Frame Mixers

Impeller Assembly Removal

In the case that there is buildup below the impeller that cannot be reached, the impeller assembly can easily be removed.

TOOLS RECOMMENDED:

Elbow High Rubber Gloves
Garbage Bag



STEP 1: With machine off locate the 3 fasteners on the top plate that attach it to the frame and remove them.

STEP 2: Firmly grasp the top plate and pull straight up on the impeller assembly.

STEP 3: Observe and clean any debris located on the bottom of the impeller.

STEP 4: Observe and clean any debris located down in the dish where the impeller rests. Place the debris into a garbage bag and remove from pond to prevent it from going through machine again. **Follow all local laws and regulations when disposing of any materials collected.**

STEP 5: Once clean, place impeller assembly back in place. Be sure bottom of impeller shaft fits into the bushing in the dish and that the 3 top plate holes are aligned with the top of the frame.

STEP 6: Replace the 3 fasteners that were removed in Step 1.

STEP 7: Turn machine back on.

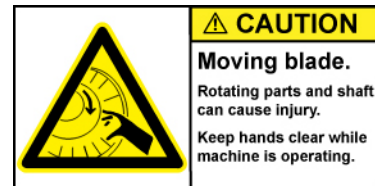

Turn Machine Off Before Performing Maintenance

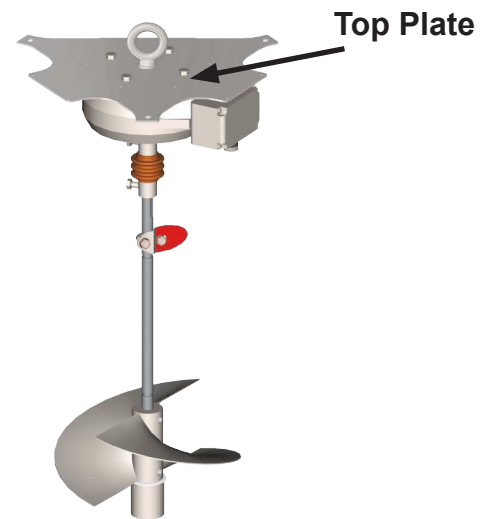

500PWc Impeller Assembly

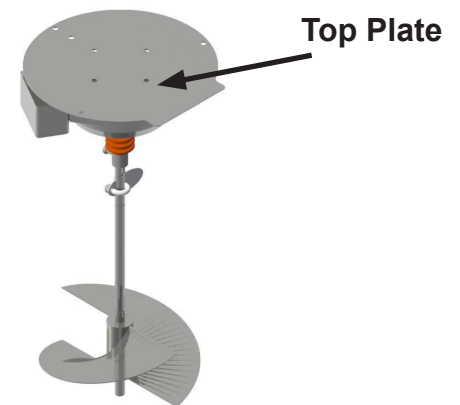

1250PWc Impeller Assembly



CAUTION: TURN MACHINE OFF BEFORE WORKING NEAR IMPELLER! WEAR PROTECTIVE GLOVES AND BE CAUTIOUS OF SHARP LEADING EDGES ON IMPELLER BLADES WHILE CLEANING! FAILURE TO FOLLOW THESE WARNINGS COULD LEAD TO INJURY!

Maintenance

Tank Maintenance

SB / GF Series Mixers, Potable Water

Tank Maintenance

The machine is designed to rest on the floor of the tank in an event when the tank is drained. If the machine is left undisturbed, the machine will naturally float and self adjust when the tank is refilled.

During the event that a potable water tank is taken off-line for maintenance for re-coating, sandblasting, or cleaning, a few considerations need to be followed for the care of the machine. The best solution for the care of the machine is to remove the unit from the tank until the maintenance is complete. Often times there is an access hatch thru the side of a tank which the machine in most cases can easily be removed. Sometimes this is not an option and the following guidelines should be followed in the event of interior tank work.

STEP 1: Turn the machine circulation equipment "Off" if the tank is projected to be dry for more than a few days. The On/Off switch is located in the machine electronic controller mounted to the pv module stand.

STEP 2: Cover the entire machine, including the hose and intake assembly, using a heavy duty tarp. Be sure to tuck the tarp under the machine to avoid any sand being collected on the machine in the case of sandblasting.

STEP 3: The electrical cord and chemical injection cord will be suspended from the ceiling so extreme care needs to be taken to prevent damage to the cord and hose from any abrasions from blasting. Both injection and electrical may be disconnected and coiled up under the tarp if desired.

STEP 4: Once the maintenance is complete, remove the tarp and reconnect the electrical cord and chemical injection hose (if applicable). The machine may need to be cleaned from any dust or sand that may have made it's way thru the tarp. A key component that should be checked and cleaned is the impeller bushing and impeller tip. Please follow the proper procedure earlier in this section.

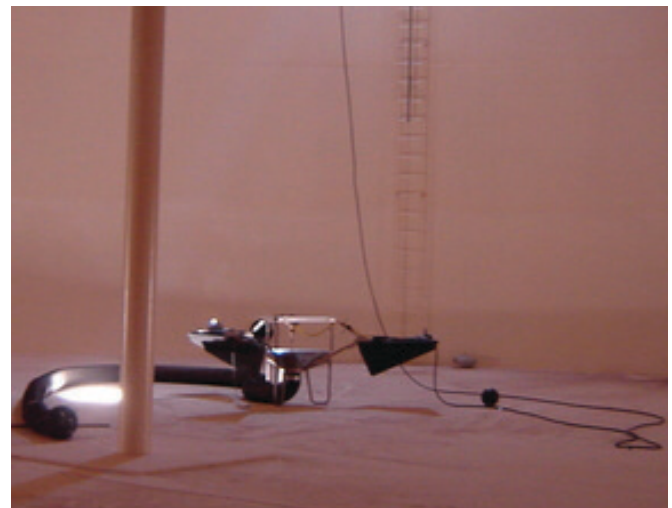

Machine power cord laying tangle free.



Machine resting on floor ready for water.

Maintenance

Tank Maintenance

SB / GF Series Mixers, Potable Water

Tank Maintenance continued,

STEP 5: Decontaminate the machine by wiping all machine surfaces using a bleach/water solution and a towel or cloth. Remove all excess dust, sand, etc. **Do not use a pressure washer to clean the machine.** This may damage the on-board electronics which may result in improper operation of the machine.

STEP 6: The machine intake needs to be placed in its original position and the entire hose layed out across the floor. *The hose should not be coiled or draped over the machine!* Reposition the electrical cord and injection hose so they do not get tangled on any objects.

STEP 7: The machine is now ready for the tank to be filled with water and be turned “On”.

Most customers feel that removing the machine circulation equipment is the best option for the safety of the equipment. Removing the equipment also allows for the contractors to perform their work freely and not have to maneuver around the machine.

Please contact Ixom Customer Service:
1-866-437-8076 (customerservice@ixom.com), for a quote for temporary removal of your machine.



Machine resting in drained tank.

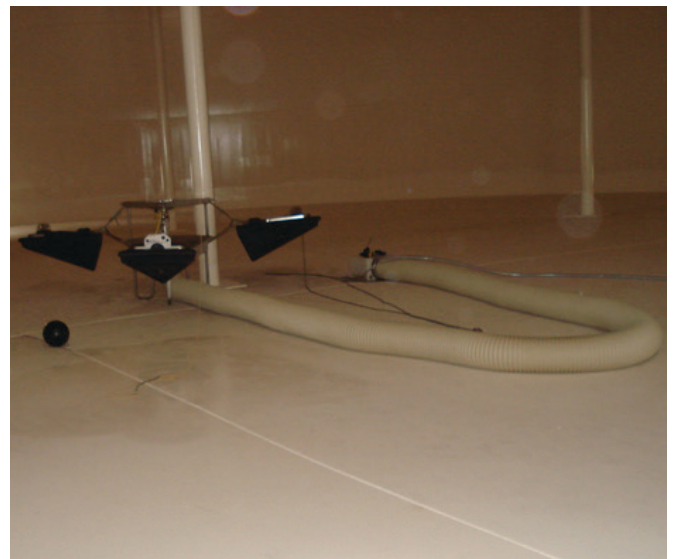

Hose properly layed out on tank floor.

Electrical

Electrical Overview

GF Series Large Frame Mixers

**GRID POWER ONLY
120VAC 60HZ @ 2.0 AMPS**







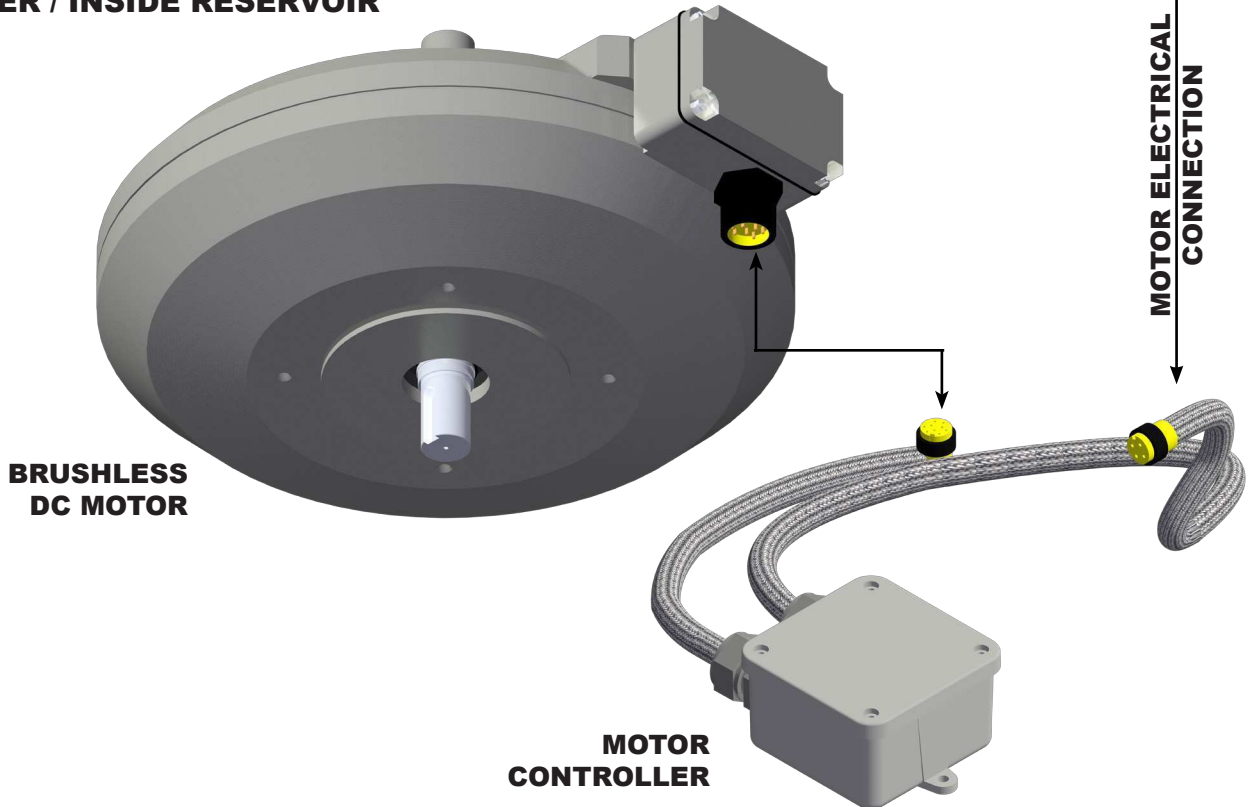







ON SHORE / OUTSIDE RESERVOIR

ON MIXER / INSIDE RESERVOIR



SolarBee/GridBee SD Card

Update Instructions

Insert the SD card into the slot. The solid blue light beside the slot will come on.	 SD CARD INSERTED
Once the correct files have been found, the green light will begin to flash rapidly.	 FILE SEARCH AND DOWNLOAD
When it is time to remove the card, the green and yellow lights will flash rapidly and be alternating. Remove the SD card from the slot.	 DOWNLOAD COMPLETE REMOVE SD CARD
When the card is removed, the red light will flash rapidly. This is the beginning of the self programming with instructions received from the SD card. After the red light is finished, the yellow light will flash rapidly, followed by the green light.	   INITIALIZING PROGRAM
Upon completion the brainboard will restart and perform a system check. Following a successful update the red light blinking once followed by one yellow blink and one green. If you miss this or are unsure, you can repeat the previous steps	   SD CARD UPDATE SUCCESSFUL
If the update was not successful, the red, yellow, and green lights will blink together 10 times. The machine will revert to the default parameters. Insert the card to attempt the update again. If it still fails, contact Customer Service.	   UNSUCCESSFUL SD CARD UPDATE

Please refer to the provided owners manual for normal operation led blink codes.

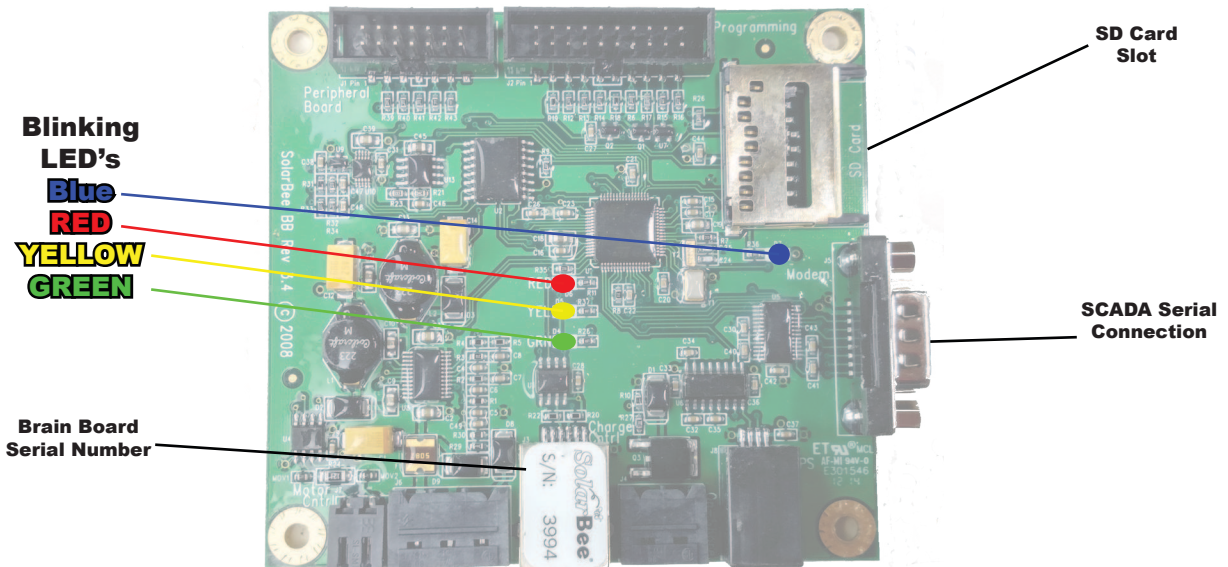

Figure 1: Brainboard

Troubleshooting

Troubleshooting

GF Series

Electrical Hazard

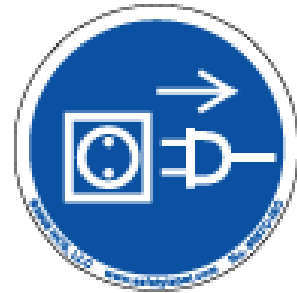

WARNING: LIVE 110VAC POWER IS PRESENT INSIDE THE ELECTRICAL BOX FOR THE MODEL GF1250PWc. DISCONNECT GRID SOURCE POWER BEFORE SERVICING THESE COMPONENTS. ONLY CONNECT GRID POWER (AC) SOURCE INTO THE PROPER LOCATION. FAILURE TO FOLLOW THIS WARNING CAN RESULT IN SERIOUS INJURY OR DEATH FROM ELECTROCUTION. TURN GRID (AC) POWER OFF BEFORE ENTERING ENCLOSURE.

IXOM WATERCARE, INC. STRONGLY RECOMMENDS THAT AN ELECTRICIAN INSTALL A BREAKER SWITCH OR OTHER TYPE OF SWITCH THAT WOULD DISCONNECT AC POWER GOING INTO THE ELECTRONIC CONTROL BOX. A SWITCH IS NECESSARY TO KILL ALL AC GRID POWER INTO THE ELECTRONIC CONTROL BOX IF THERE BECOMES A NEED TO PERFORM ANY TYPE OF SERVICE INSIDE THE ELECTRONIC CONTROL BOX.

Troubleshooting

Troubleshooting

GF Series

If you find that the GridBee has quit operating, the following checks can be performed by a qualified person such as an electrician:

Checks -

- 1) Verify that there is power available to the control box and the On/Off switch is in the On Position.
- 2) Confirm that the motor circuit fuse (4 Amps) is not blown.
- 3) Follow each cord from the external electronic controller to its originating component and be sure it is not damaged or compromised.

OPTIONAL Visual Electronic Controller Check

- The GridBee contains an LED (Light Emitting Diode) blink sequence that indicates the machine operation status. The blinking LEDs are found on the Brain-board located inside the control box. Normal GF10000PW operation will include a 4X Red Blink Code.

DC Voltage Check -

If a DC voltmeter is available, the motor circuit voltage can be measured off terminal blocks 1 and 2. The proper motor voltage should be approximately 45vDC

Brain Board voltage should be approximately 12vDC and can be measure as shown to the right.

Ixom Watercare, Inc. is committed to serving our customers. Feel free to contact a Ixom Watercare, Inc. Customer Service Representative if you experience any problems with your GridBee. At Ixom Watercare, Inc., we will get you technical support, parts, or a service visit to make sure that your GridBee is back online in short time. (866) 437-8076 or customerservice@ixom.com



12 VDC+ 12 VDC-

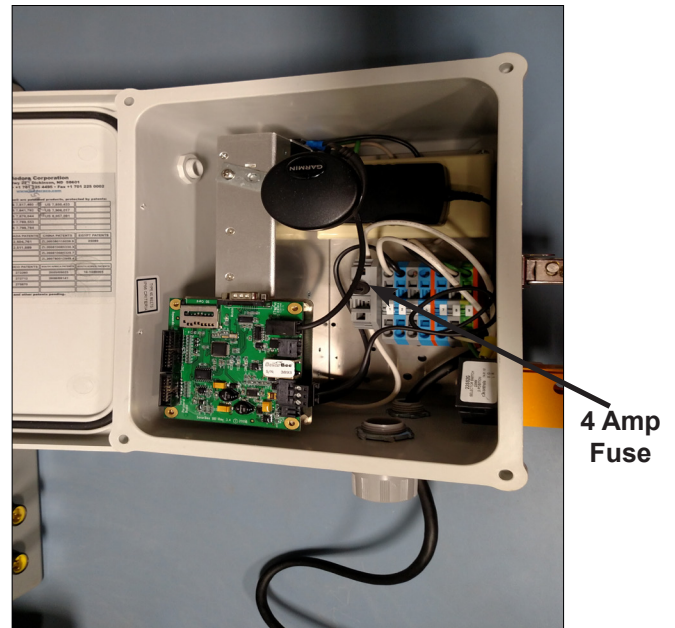

4 Amp Fuse

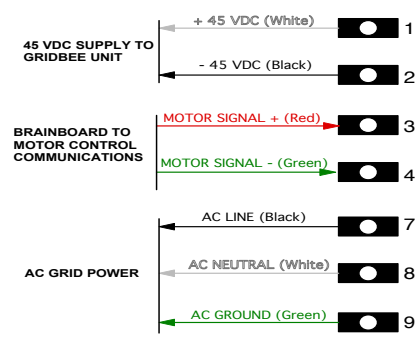

Parts Diagram

GF1250PWc Parts Diagram

NO.	PART#	DESCRIPTION
01	PN: 22281012	Impeller Assembly
02	PN: 24280114	Float Assembly
03	PN: 14013022	Motor Control Cord
04	PN: 20504700	Brushless Motor
05	PN: 100161	Control Box with Brainboard
06	PN: 26060840	8" x 40' Hose, NSF, White
07	PN: 18010015	Distributor Dish
08	PN: 26283008	Intake Box Assembly

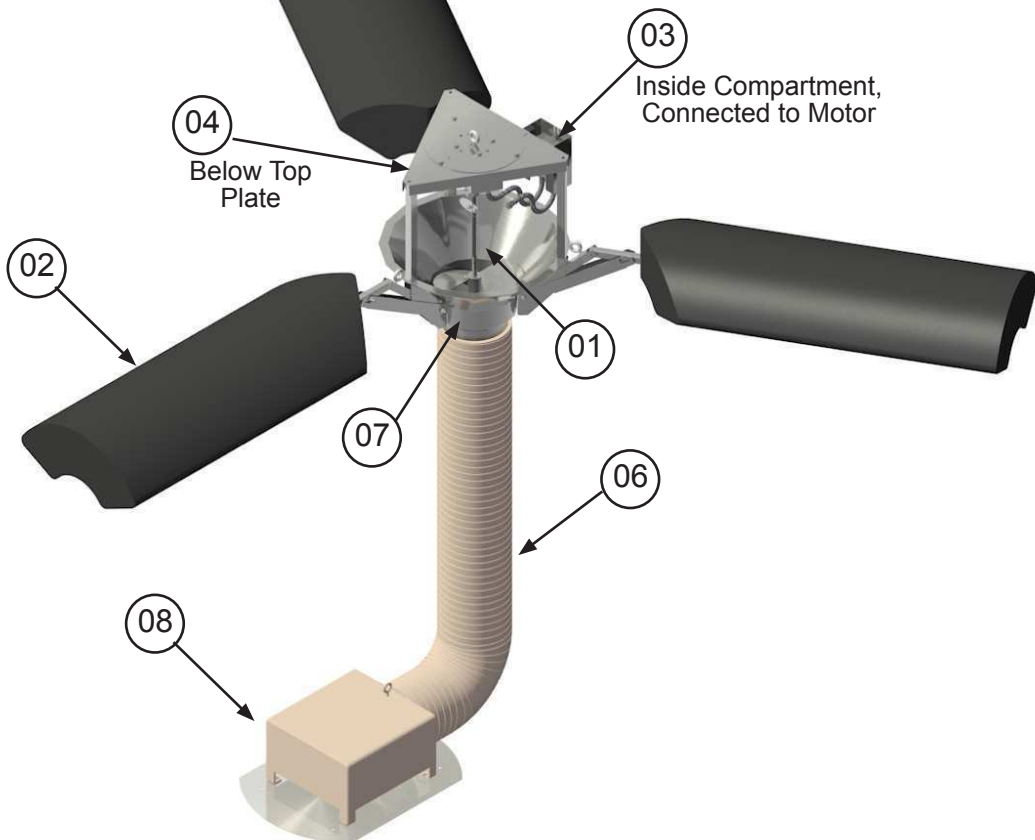

Dimension Drawing

1250PWc Dimension Drawing

SB / GF Series Small Frame Mixers

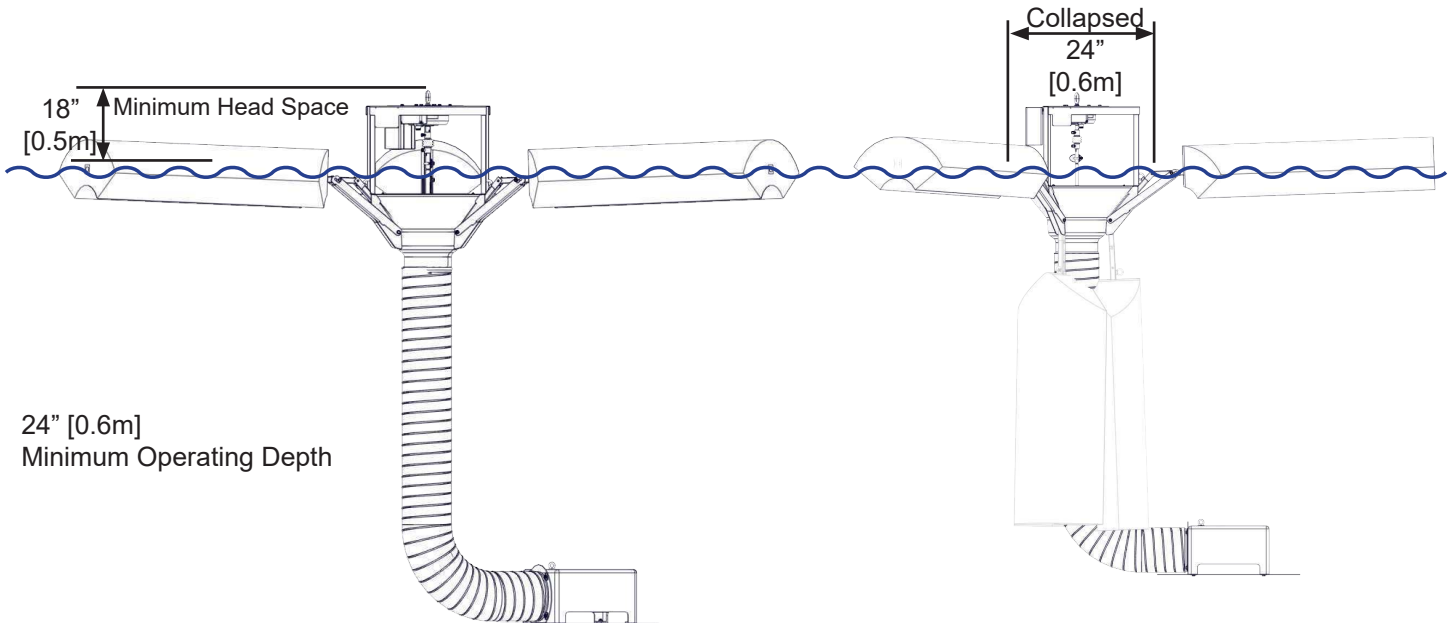
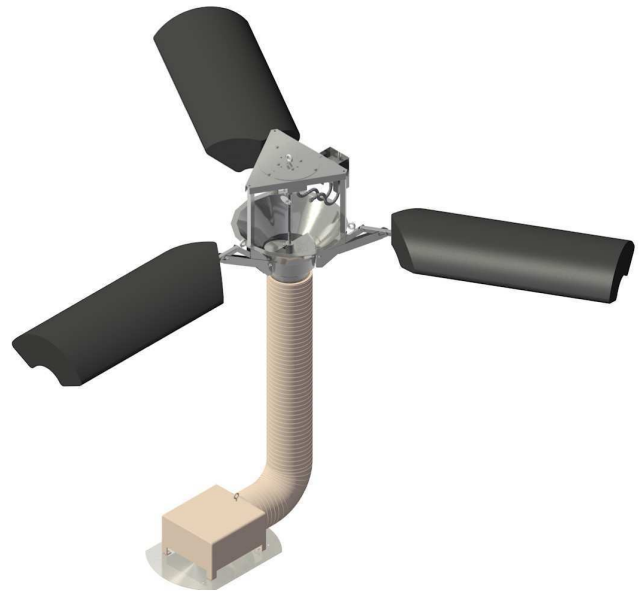
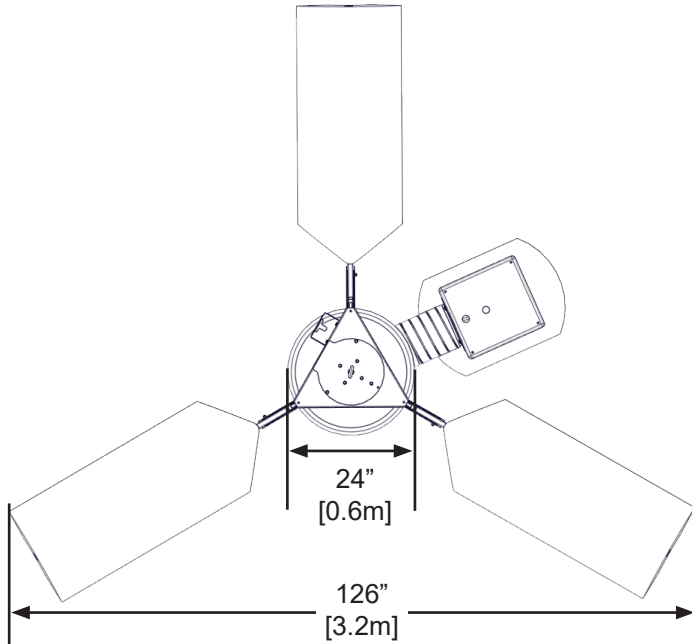

Appendices



Appendix

Additional Component Information

Technical Data Sheets

Technical Data Sheet

GF1250PWc

Technology Description- Floating, grid powered, circulation equipment for potable water reservoirs. Day/night operation.

Materials of Construction - T316 stainless steel constructions. Foam-filled high-density polyethylene (HDPE) floats. Thermoplastic rubber intake hose. HDPE Strainer.

The GF1250PWc is NSF/ANSI Standard 61 Listed, includes NSF/ANSI 61, Annex G.



Minimum Access Opening / Machine Size / Weight -

Machine can be installed through 24 inch (61 cm) diameter opening. Assembled machine is 10 feet (3.0 meter) in diameter in floating position and weighs 200 pounds (90 kg).

Drive System - High torque, direct drive (no gearbox), axial airgap Lorentz force brushless D.C. motor.

Minimum Operating Depth - At depths below 2 feet (0.6 meters), the impeller will be out of the water and the machine will stop circulating water. No damage to machine if ran dry in shallow water.

Minimum Head Space - 18 inch (0.5meter) headspace is required.

Flotation System - Three floats in triangular pattern each with an adjustable float arm, total float buoyancy of 600 lbs (270 kg).

Power Supply/Control System - Requires 120 VAC power source (15 Amp Service Adequate), nominal power consumption is 15 Watts. Power converter 120 VAC input, 45 VDC output.

Wiring: Corrosion-resistant industrial cord with molded watertight connectors that are indexed to prevent improper wiring. Low voltage in reservoir, less than 45 VDC.

Rotating Assembly - Removable assembly with easy access to impeller and impeller shaft.

Fluid Intake Assembly - Intake hose banded to bottom of structural assembly.

Intake Hose : 20 to 60 feet (6 to 18 m) available in 8-inch (20 cm) diameter X 20 feet (6 m) sections.

Intake Assembly at Bottom of Hose: Rectangular intake with openings around perimeter.

Intake Depth Adjustment: No depth adjustment is necessary for fluctuations in water level. Intake draws water in a horizontal layer within 1 inch (2.5 cm) of the tank or reservoir floor.

Chlorine Boosting - Chlorine boost hose, accessible at top of reservoir spans down and connects to intake for fast chlorine dispersion during in-reservoir boosting.

Accessories Available - (1) Portable Chlorine Boost System, (2) LED RPM Indicator

Shipping Size / Weight

• **Crate** - 4 feet W X 6 feet L X 5 feet H (1.2 m x 1.8 m x 1.5 m) / 500 pounds (225 kg) Exact weight and dimensions varies dependent on machine configuration.

Maintenance / Warranty - Minimal maintenance. Limited 2-year parts and labor warranty.

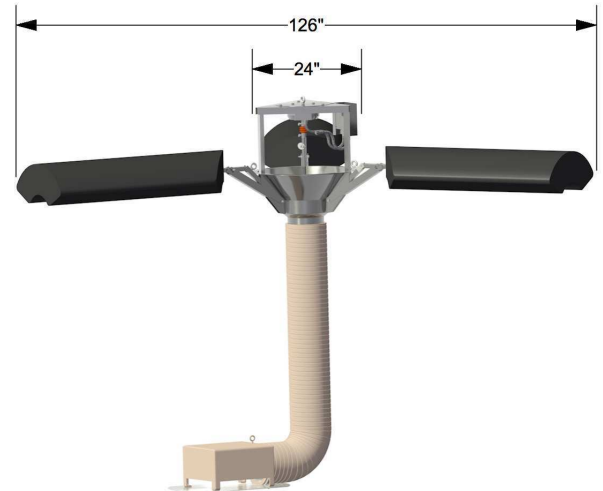

Figure 1: GF1250PWc

GridBee GF Series SCADA Output

The GridBee GF with SCADA package provides the following SCADA output capabilities: Controller shall have RS-232 serial communication (Modbus RTU), DB9 male connection point.

Parameters available for monitoring:

- 1) Motor RPM
- 2) Motor Direction
- 3) Motor Current
- 4) Visual Indicator Status

SCADA Accessory Packages:

- Wireless Radio
- RS-232 to RS-485 Converter

GridBee Monitoring Setup Information

The GridBee is a modbus RTU slave device with a factory programmable slave ID. The ID can be changed in the field with a properly programmed SD card. Contact Ixom Watercare, Inc. Customer Service for assistance.

Serial Interface

Type: RS-232

Connector: 9 pin male D-Sub

Pin assignments:

- | | |
|---|---|
| 1 | n/c |
| 2 | RXD Receive Data Input |
| 3 | TXD Transmit Data Output |
| 4 | n/c |
| 5 | Signal Ground |
| 6 | n/c |
| 7 | n/c |
| 8 | n/c |
| 9 | +12VDC, 1 Amp max
(Can be used to power some serial devices) |

Serial/Modbus Communication Parameters

Rate: 19200 Baud

Bits/byte: 8

Stop bits: 1

Parity: N (none)

Handshake: None

Time between bytes sent to GridBee controller:
No greater than 20 milliseconds

Time between commands sent to GridBee controller:
At least 50 milliseconds

Read Holding Register

The GridBee supports modbus Function 3 - Read Holding Register.

A properly formatted "Read Holding Register" modbus message will be replied to with holding register data. The "Read Holding Register" message consists of the GridBee slave address, the function (3), two bytes of register address, two bytes of number of points, and the CRC. The address of the holding registers can be found in the table below.

The format of the reply consists of the GridBee slave address, the function (3), a byte count (number of data bytes), two bytes of data for each of the requested points, and the CRC.

When monitoring several GridBees on the same modbus network, query them sequentially. That is, query one GridBee and wait for its response, query the next GridBee and wait for its response, etc. Querying the GridBees in a manner such that the query/response messages can overlap or collide will cause inconsistent communication.

GridBee GF Series SCADA Output

Description of Holding Registers in Order of Importance (Memory Table starts at zero, 0)

Register Address (Base 10)	Status Item	Description
0	NA	Not Applicable
1	NA	Not Applicable
2	NA	Not Applicable
3	NA	Not Applicable
4	Current Epoch High	<p>This is the date and time data for the GridBee. The format is the same as that of the "Unix epoch", (Epoch High * 65536 + Epoch Low), where the value is the number of seconds since 00:00:00 UTC on January 1, 1970. This value is set by the GPS hardware in the GridBee controller.</p> <p>Querying register 5 and testing the response against the previous value is a good way to monitor the communication link between the modbus master and the slave GridBee controller.</p>
5	Current Epoch Low	
6	NA	Not Applicable
7	NA	Not Applicable
8	NA	Not Applicable
9	Visual Status Indicator	<p>This value gives an indication of the GridBee controller health blink indicator. During normal operation the following values will appear:</p> <p>4 = (4 Blink Red = Healthy Operation)</p> <p>Any other indication requires attention:</p> <p>3 = (3 Blink Red = Motor Controller Communication Error)</p>
10	Motor Speed	The unit for this value is RPM in hundredths. To obtain RPM, divide the value by 100.
11	Motor Direction	The value of 0 indicates that the motor will be stopped, the value of 1 represents movement in the forward direction, whereas the value of 3 indicates reverse movement. Viewed from behind or above the motor clockwise motion is "forward".
12	Motor Current	The unit for this value is milliamps.

System Status for GridBee GF SCADA

Register Address 7 (Base 10)

Value of Zero indicates normal, healthy operation. Any other value indicates a subsystem or multiple subsystem errors. See below.

Binary Designation(s)	Decimal Value	Error Meaning
Bit 0 = 1	1	GPS Communication (Comm) Error
Bit 2 = 1	4	Motor Comm Error
Bits 0 and 2 = 1	5	GPS Comm and Motor Comm Error
Bit 3 = 1	8	Analog Out of Range (OOR) Error
Bits 0 and 3 = 1	9	GPS Comm and Analog OOR Error
Bits 2 and 3 = 1	12	Motor Comm and Analog OOR Error
Bits 0, 2, and 3 = 1	13	GPS Comm, Motor Comm, and Analog OOR Error

For Customer Service, contact Ixom Watercare, Inc. Office and Service Center at 866-437-8076.

Table 4 - Visual Status Indicator (Register Address 9) - Priority Levels

Priority Level	LED Behavior	Indication / Cause
Priority 1	3X Red	Motor Controller not communicating properly. If the Charge Controller has the Auxiliary Output turned off, this error is not displayed.
Priority 2	4X Red	Normal machine operation.

Small 7" Brushless Motor

Motor Features

Technology Description- Designed for Solarbee and Gridbee circulation equipment. The brushless direct drive motor provides high torque, eliminates costly gearboxes, and provides high reliability. The motor requires no brush replacement, no lubrication, and no routine maintenance. An iron free stator eliminates iron saturation to provide long life. It also provides a smooth, vibration free operation. Quite operation at low speeds. Operational power requirements utilize low voltage DC power. Using hall effects for electronic communication. Provides effective use of solar and DC energy.

7" Motor Specifications		
Size	7-inch (18cm) diameter X 4-inch (10cm) height	
Weight	25 lb (12 kg)	
Housing	Sealed 356-T6 Cast Aluminum	
Shaft	Stainless Steel: V-ring seal	
Thrust Bearing	L10: 100,000 hrs. Stainless Steel	
Motor Control	Anti-Corrosive coating on flux returns and magnets Encapsulated stator Conformal coating on commutation circuit board Hall Effect Commutation	
Receptacle	#16-9, 7A, 600V AC/DC, IP68, NEMA 6P, UL/CSA	
	Normal Operation	Maximum Motor Ratings
Current	Less Than 0.5 Amp	2.4 Amps
Voltage	36 VDC	36 VDC
Torque	1ft-lb (1.4 N-m)	10 ft-lb (14 N-m)
Power	1/50 HP (15 W)	1/8 HP (86 W)
Environment	-40 to 140°F, freeze resistant, 100% humidity, splash and condensation resistant	

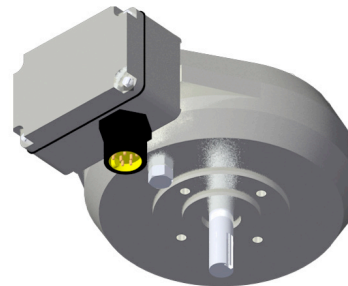
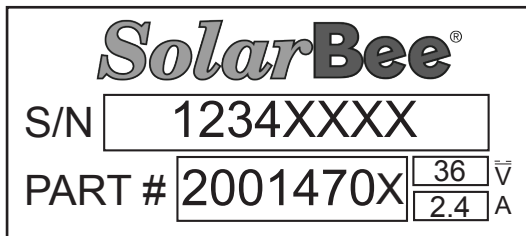

Shipping Size/Weight

- 14" x 10" x 9", 30lbs.

Maintenance / Warranty - No routine maintenance. Limited 2- year parts and labor warranty.

Warranty



GridBee GF Mixers

Limited Replacement Warranty

GridBee GF Mixers. GridBee GF mixers and circulators are warranted to be free of defective parts, materials, and workmanship for a period of two years from the date of installation. GridBee SCADA and any optional accessories are considered “buyout” items for Ixom, and as such include a warranty against defects in material and workmanship for two years from the date of purchase. Parts that are determined by Ixom to be defective in material or workmanship under normal use during the two year warranty period will be repaired or replaced. Any shipping charges that may apply are the responsibility of the customer. A This warranty is valid only for GridBee equipment used in accordance with the owner’s manual, and consistent with any initial and ongoing factory ecommendations. This warranty is limited to the repair or replacement of defective components only and does not apply to normal wear and tear. If the factory’s service crews performed the original on-site placement and startup, then this warranty also includes labor. Where labor is included, in lieu of sending a factory service crew to the site for minor repairs, Ixom may choose to send the replacement parts to the owner postage-paid and may pay the owner a reasonable labor allowance, as determined solely by Ixom, to install the parts. There is no liability for consequential damages of any type. The warranty that is submitted and provided with the purchased equipment is the valid warranty.

Terms applicable to all equipment. This Limited Replacement Warranty is subject to the terms of Ixom’s General Terms and Conditions of Sale. In the event of any inconsistency between the terms of this Limited Replacement Warranty and Ixom’s General Terms and Conditions of Sale, the terms of this Limited Replacement Warranty shall prevail to the extent of that inconsistency.

Protect Your Investment With The Ixom Service Program

Comprehensive Damage Repair

Damage which occurs to your Ixom manufactured equipment in the normal course of operation will be repaired or replaced including supply and installation of structural repairs and replacement parts in accordance with Ixom's standard terms & conditions.

Trained & Experienced Service Technicians

The Ixom Service Program allows our customers to take advantage of our highly trained service technicians. We have the equipment, experience and training to ensure the machines are well maintained while following OSHA regulations. Our dedication to safety and high level of training has earned us the prestigious SHARP recognition award time and time again. We have the means to safely service the equipment whether in municipal water tanks, lakes, reservoirs, or wastewater ponds & basins.



Guaranteed Annual Onsite Maintenance

Ixom service personnel will perform a minimum of one (1) onsite equipment inspection & maintenance per yearly term of the service contract including mechanical, structural, and electronic components of Ixom manufactured equipment.

On-Site Crew Response for Critical Application and Operational Service Issues

If service issues arise, the customer may be asked to perform a basic machine inspection and discuss results with Ixom's Customer Service Department. In some cases, the customer may be asked to perform minor tasks (i.e., cleaning, basic troubleshooting, and replacing minor parts). If replacement parts are needed, the factory will ship them out at no cost. For more serious application and service issues, Ixom will dispatch service personnel to resolve the issues onsite.



Removal, Storage, and Redeployment of Equipment

For situations when Ixom equipment needs to be removed, stored, and redeployed, services can be offered at a discounted rate.

Access to On-Staff Water Quality Experts

Ixom employs many experts in the water quality field including specialized areas such as limnology, hydrology, wastewater, biology, and engineering. Our water quality personnel are available for data analysis and troubleshooting when you need it.



Contact us for a quote!

Call +1 866-437-8076 or email us at watercare@ixom.com

IXOM

WATERCARE

Nationwide Installation & Service

EVERYONE DESERVES GREAT CUSTOMER SUPPORT

Ixom Watercare earns customer trust with unparalleled service start to finish. Every department in Ixom is dedicated to the support of our Customers and the improvement of water quality. Complete life cycle support is much, much more than a returned phone call or an email. It centers around direct access and communication to those who can help when help is needed from the beginning of a project throughout the life of the equipment.

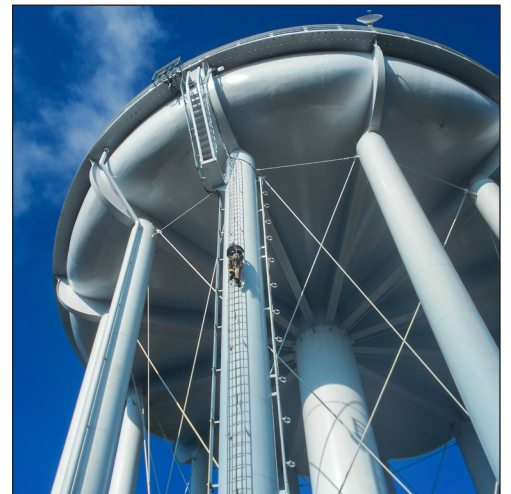

ABOUT IXOM

Ixom combines innovative water quality solutions with top notch manufacturing and nationwide in-field service capabilities to create trusted, full circle support our Customers depend on.

We design and manufacture many trusted brands including GridBee®, SolarBee®, MIEX®, and ResidualHQ® for use across the water quality spectrum. This includes solutions for Water Treatment, Distribution Treatment, Wastewater Treatment and Lakes & Source Water Reservoirs.

Ixom has thousands of installations and is an industry-leader solving water quality problems across the United States, Canada and the world.

Contact us today to discuss your water quality and service needs.

ixomwatercare.com
866-437-8076 • watercare@ixom.com