

# GridBee SN 1

## Owner's Manual

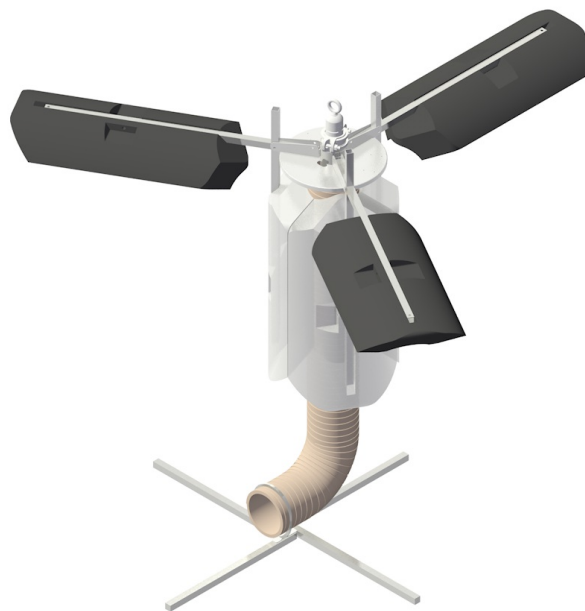

# Table of Contents



## GridBee SN 1 Owner's Manual

---

Safety	1
Package Contents	4
Tools Required	6
Placement	7
Requirements	10
Electrical	11
Assembly	12
Final Checklist	18
Operation	19
Technical Specifications	20
Exploded Parts Diagram	23
Dimension Drawing	24
Warranty	25
Service Program	26

---

## Safety

# IMPORTANT

**YOU MUST COMPLETELY  
READ AND FULLY  
UNDERSTAND THESE  
INSTRUCTIONS BEFORE  
INSTALLING, OPERATING,  
OR SERVICING THIS UNIT.**

**Be sure you have read all installation, operation, maintenance and safety instructions before you install, service or begin to operate this unit.**

Accidents occur every year because of careless use of industrial equipment. You can avoid hazards by following these safety instructions, and applying some ordinary common sense when operating or servicing this unit.

Keep in mind that **full operator attention and alertness** are required when operating or servicing this unit.

**USE COMMON SENSE!!** Most accidents can be avoided by using **common sense and concentration** on the job being done.



Carefully read safety information when you see any safety symbols.



# Safety

## IMPORTANT

**YOU MUST COMPLETELY READ AND FULLY UNDERSTAND THESE INSTRUCTIONS BEFORE INSTALLING, OPERATING, OR SERVICING THIS UNIT.**

Identify all possible hazards. Determine what safeguards are needed and implement them. **Only you, the user,** understand your product and system characteristics fully. *The ultimate responsibility for safety is with you. Your safety ultimately rests in your hands.* Do your part and you will enjoy safe, trouble free operation for years to come. This instruction manual is not intended to include a comprehensive listing of all details for all procedures required for placement, operation and maintenance. If you have a question about a procedure or are uncertain about any detail, **Do Not Proceed.** Please contact Ixom Watercare Customer Service at **866-437-8076** to speak to a representative.



### **IMPORTANT!!!**

Follow all federal and state laws in regards to safety regulations of working at heights, confined spaces, rescue, etc. as required by the U.S. Department of Labor, Occupational Safety and Health Administration. Use necessary PPE when placing and servicing this unit.



### **Thin Ice Hazard**

**WARNING:** ICE SURROUNDING MACHINE MAY NOT SUPPORT WEIGHT, KEEP CLEAR OF THIN ICE.



### **ELECTRICAL HAZARD**

**WARNING:** THIS EQUIPMENT CONTAINS HIGH VOLTAGE! ELECTRICAL SHOCK CAN CAUSE SERIOUS OR FATAL INJURY. ONLY QUALIFIED PERSONNEL SHOULD ATTEMPT PLACEMENT, OPERATION AND MAINTENANCE OF ELECTRICAL EQUIPMENT. REMOVE ALL SOURCES OF ELECTRICAL POWER BEFORE PERFORMING ANY SERVICE WORK TO THE MACHINE. USE PROPER LOCKOUT TAGOUT (LOTO) PROCEDURES TO ENSURE A SAFE WORK ENVIRONMENT.



### **Crush Hazard**

**WARNING:** DO NOT REMOVE ANY FLOAT ASSEMBLY BOLTS OR PINS WHILE EQUIPMENT IS FLOATING IN WATER. EQUIPMENT MUST BE SECURELY SUPPORTED BEFORE PERFORMING SERVICE.



### **Rotating Hazard**

**CAUTION:** KEEP BODY APPENANDAGES OR LOOSE CLOTHING AWAY FROM EQUIPMENT WHILE OPERATING. ENSURE EQUIPMENT IS OFF BEFORE ATTEMPTING SERVICE.



### **Entanglement Hazard**

**WARNING:** ENSURE THAT PERSONNEL ARE CLEAR OF THE ELECTRIC CORD AND CHAIN TO AVOID ENTANGLEMENT.



### **Laceration Hazard**

**CAUTION:** EDGES MAY BE SHARP AND CAUSE LACERATION IF PROPER CARE IS NOT USED.



# Safety

## Protect Yourself

It is important that you comply with all relative OSHA and local regulations while installing and performing any maintenance to the mixer circulation equipment.

Key OSHA Compliance Standards that must be followed (and not limited to) are:

- **1910.146 Permit-required confined spaces**
- **1910.147 Lockout/Tagout**
- **1926.500 Fall Protection**

## Fall Protection Tips

- Identify all potential tripping and fall hazards before work starts.
- Look for fall hazards such as unprotected floor openings/edges, shafts, open hatches, stairwells, and roof openings/edges.
- Inspect fall protection and rescue equipment for defects before use.
- Select, wear, and use fall protection and rescue equipment appropriate for the task.
- Secure and stabilize all ladders before climbing.
- Never stand on the top rung/step of a ladder.
- Use handrails when you go up or down stairs.
- Practice good housekeeping. Keep cords, welding leads and air hoses out of walkways or adjacent work areas.

Refer to 29 CFR 1926.500 for complete regulations set by OSHA. Refer to your state's regulations if your state established and operates their own safety and health programs approved by OSHA.

## Lockout Tagout

When the On/Off switch is in the "ON" position, the mixer may start up at any time if not already operating. The mixer's On/Off switch can be locked out by placing a pad lock thru the door latch of the controller after the switch has been turned to the "OFF" position. The On/Off switch is to be used as the emergency stop.



## Permit-Required Confined Spaces

A confined space has limited openings for entry or exit, is large enough for entering and working, and is not designed for continuous worker occupancy. Confined spaces include underground reservoirs, ground storage tanks, elevated tanks, silos, manholes, and pipelines.

## Confined Space Tips

- Do not enter permit-required confined spaces without being trained and without having a permit to enter.
- Review, understand and follow employer's procedures before entering permit-required confined spaces and know how and when to exit.
- Before entry, identify any physical hazards.
- Before and during entry, test and monitor for oxygen content, flammability, toxicity or explosive hazards as necessary.
- Use fall protection, rescue, air monitoring, ventilation, lighting and communication equipment according to entry procedures.
- Maintain contact at all times with a trained attendant either visually, via phone, or by two-way radio. This monitoring system enables the attendant and entry supervisor to order you to evacuate and to alert appropriately trained rescue personnel to rescue entrants when needed.

Refer to 29 CFR 1910.146 for complete regulations set by OSHA. Refer to your state's regulations if your state established and operates their own safety and health programs approved by OSHA.

# Package Contents

## SN1 Spray Unit Contents

**Crate Unpacking Note: A #2 Square Driver Bit is required for crate disassembly**



SN1 Core Unit



6" x 40' White Hose



Hardware Kit, SN1  
White Tote Kit



50' Stainless Steel  
Retrieval Chain



F1 Ventilation Blower,  
Completely Assembled



3DX Nozzle



Submersible Electric Cord



Torque Bar Assembly (M8 or 1/2" Box  
Wrench & Socket Wrench Not Supplied)

# Package Contents

## Hardware Kit, White Tote Contents



6" Hose Tube Insert



(2) 6" Hose Clamps  
(5/16" Nut Driver Not Supplied)



Cord Grip



Epoxy Splice Kit



Epoxy Tube  
(Caulk Gun Not Supplied)



1 5/16" Hole Saw  
(Cordless Drill Not Supplied)



2 1/2" Hole Saw  
(Cordless Drill Not Supplied)



Universal Fixture



Anti-Seize Tube



Lexel  
Sealant Tube



(3) Float Lock  
Clevis Pins



(2) Kellerm Grip  
Cord Strain Reliefs



(3) Hair Pins



(6) Quick Link

## Tools Required

## SN Series - Small Frame

### Tools Required

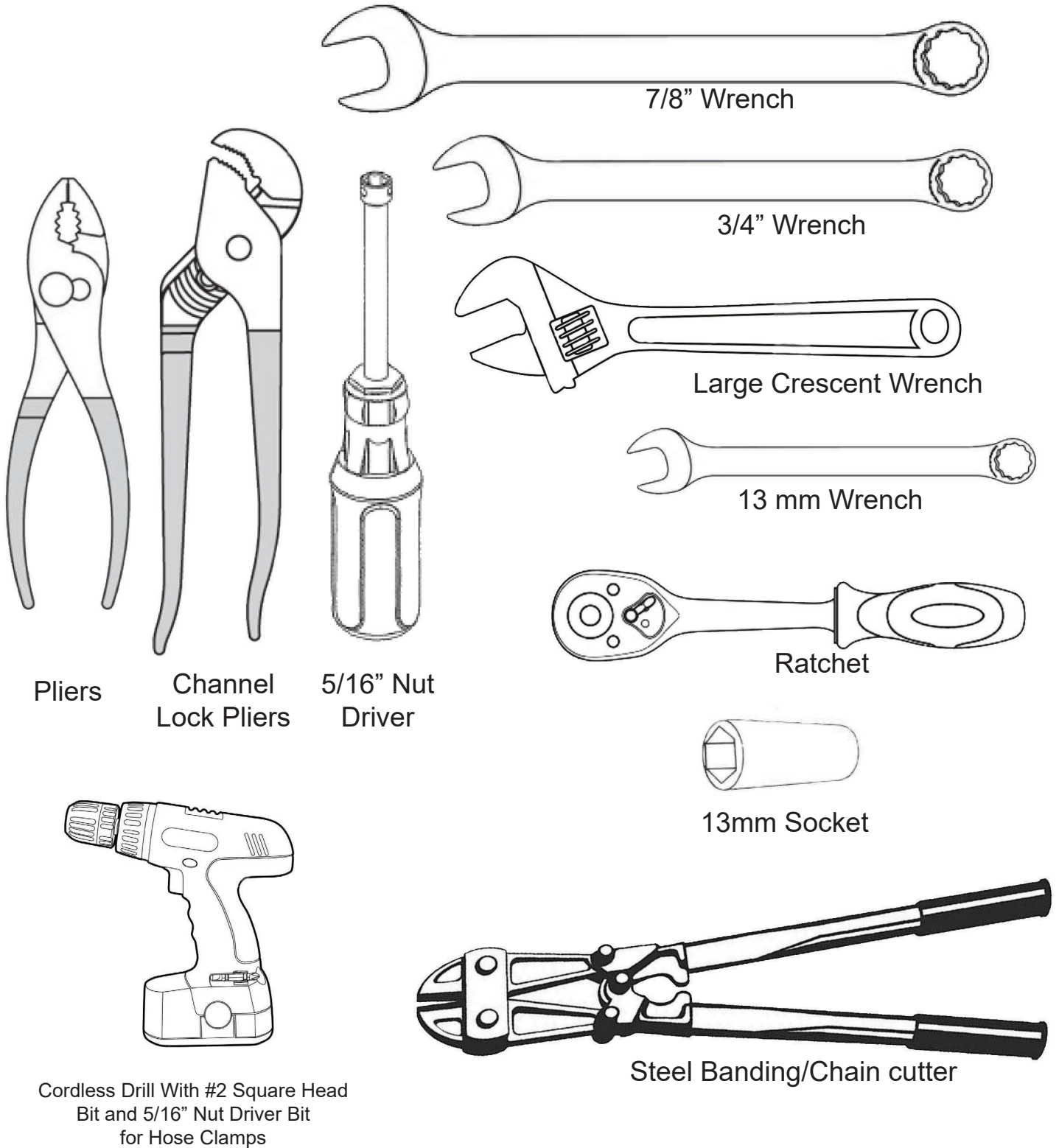

# Placement Site Preparation

## SN Small Frame Placement

### SN Small Frame Series

Properly planning out the job site before proceeding is very important to performing an efficient and successful potable water equipment placement. Every potable water tank and reservoir is unique; therefore, the following are general guidelines and considerations that will need to be evaluated for each specific site.

#### Hatch Requirements

Hatch size must require a minimum clear opening of at least 18 inch x 18 inch square (46cm x 46cm) to allow the SN Small Frame collapsible unit assembly to be placed. To place the unit in the collapsible setting, the hatch needs to be 24 inch x 24 inch (61 cm x 61cm).

#### Wet Or Dry Placement

A decision will be required to either place the machine while the reservoir is empty or filled with water.

Wet placements are generally preferred when the units are placed by our factory placers to allow for proper final adjustments and settings during startup which directly follows placement. Our factory placement teams have extensive training and many placement tools to assist in a wet placement.

If proper equipment and safety training are not available, a wet placement should not be attempted, and therefore a dry placement will be required and startup will have to follow at a later time once the reservoir is filled with water.

#### Sanitary Requirements

For potable water equipment placements, it is very important to maintain sanitary conditions by properly disinfecting all equipment and personnel that come into contact with the reservoir interior and potable water. It is recommended that once the hatch is chosen for equipment and personnel entry, a clean zone be designated around the hatch. The clean zone establishes a boundary where anything that comes in contact with that zone shall be sanitary and adequately disinfected, allowing it to pass through the clean zone and into the reservoir. Standard practice in the United States is to use a 200 part per million sodium hypochlorite in water solution as a disinfectant to all equipment and personnel clothing/footwear coming into contact with the reservoir interior and potable water.

#### Safety

Prior to commencing placement and finalizing the placement work areas, the jobsite should be evaluated for all safety hazards including, but not limited to: Confined Space Entry, Fall Protection, Working Over Water, Overhead Equipment, Communication Barriers, Equipment Handling, etc.

Once safety hazards are identified, hazard mitigation measures should be taken and safety training procedures must be practiced to accomplish the placement without incident.



# Placement

## Placement Overview

### SN Small Frame Series

Details listed on this page include items provided by Others, not Ixom. Please refer to your projects Scope of Work for more details. Ixom does not provide any electric work.

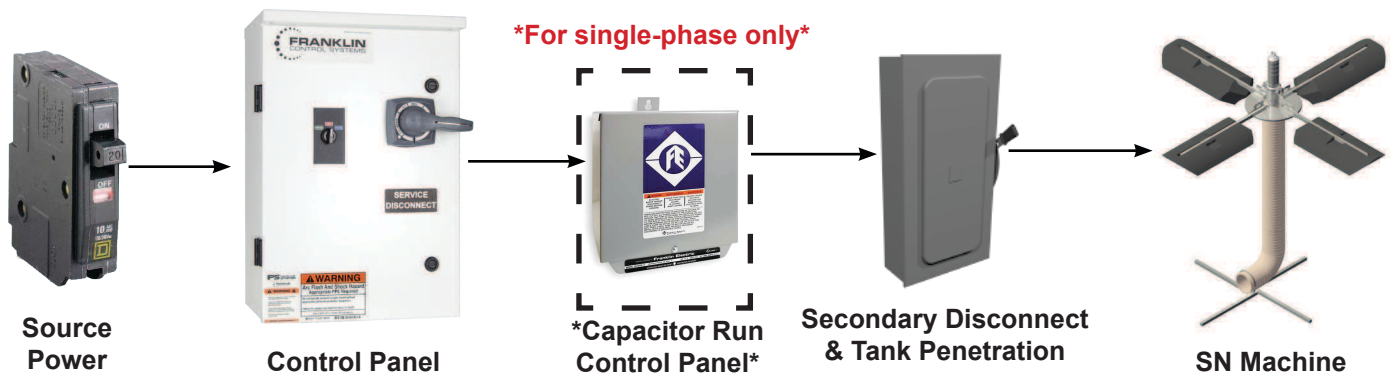
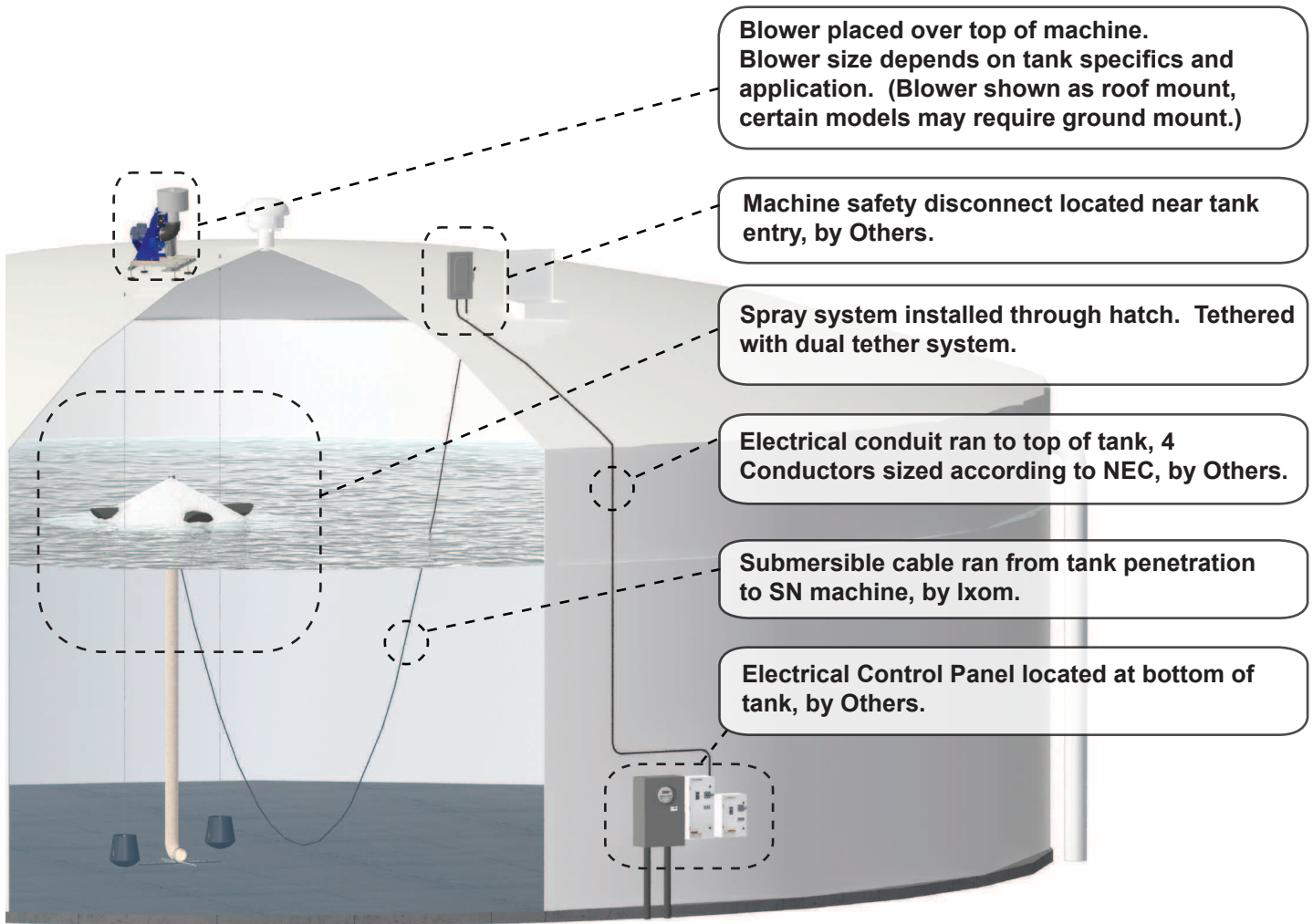

# Tethering

## Visual Dual Tethering

Small Frame SN and SB

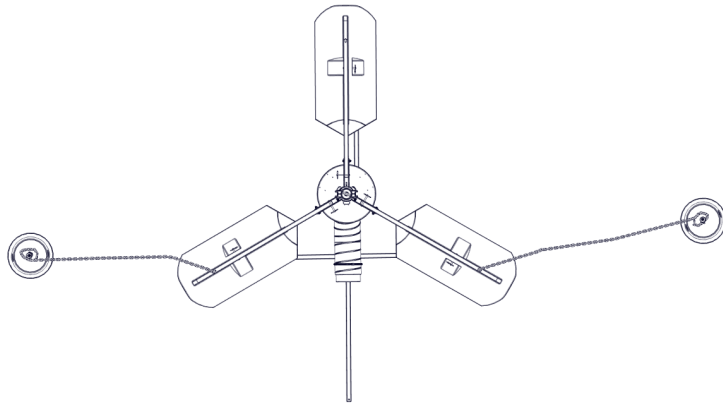

**TOP VIEW SN DUAL TETHERING**

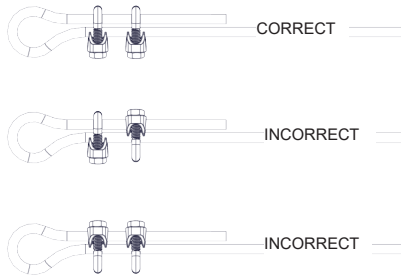

**CABLE CLAMP DETAIL**

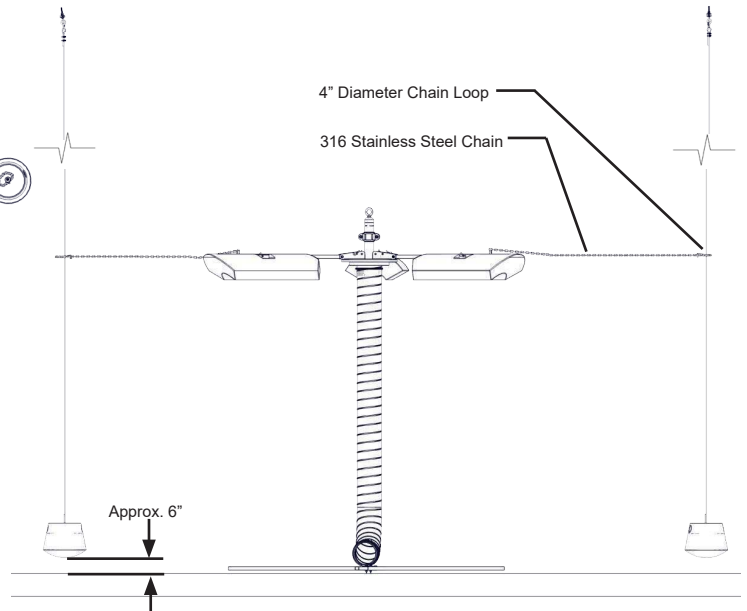

**FRONT VIEW SN DUAL TETHERING**

**CONCRETE ROOF**

\* Anchor provided by Contractor / Tank Manufacturer

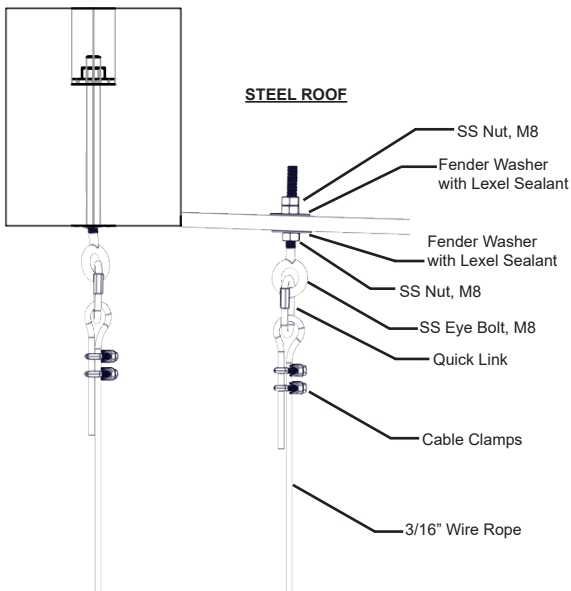

**ROOF CONNECTION DETAIL**

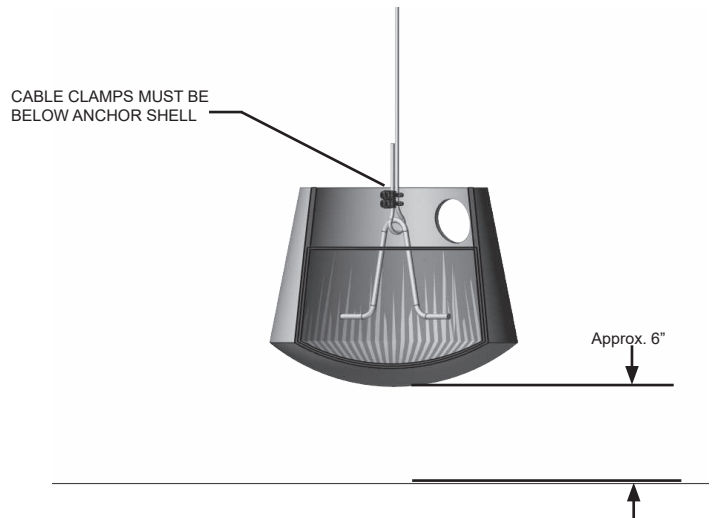

**MOORING BLOCK CONNECTION DETAIL**

# Requirements

## SN1 Requirements

### Electrical Integration

#### Hatch Requirement

A 18 inch (460 mm) diameter hatch opening is required to fit the SN1 through.

#### Power Requirement

SN1 Spray Unit: 240vAC, 30 amp double pole service and means of quick power disconnect recommended.

F1 Ventilation Blower Unit: 240vAC, 20 amp double pole service and means of quick power disconnect recommended.

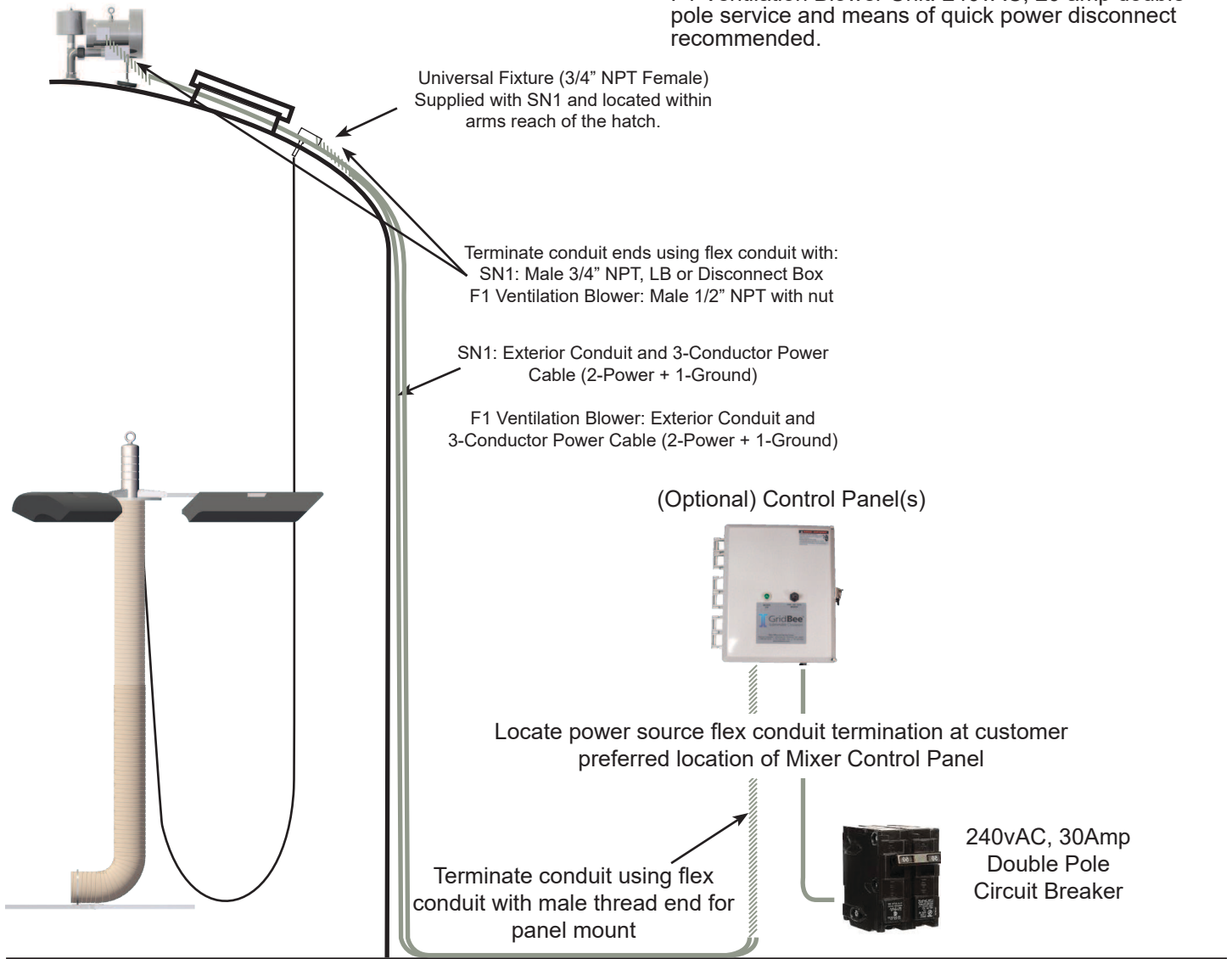

Figure 1: Typical SN1 Placement

TYPE	RATING					FULL LOAD		MAXIMUM LOAD		WINDING RES. IN OHMS	EFFICIENCY		POWER FACTOR %		LOCKED ROTOR AMPS	KVA CODE
	HP	KW	VOLTS	HZ	S.F.	AMPS	WATTS	AMPS	WATTS	RES.	S.F.	F.L.	S.F.	F.L.		
SN1	1.5	1.1	230	60	1.3	10.6	1770	13.1	3400	1.5 - 2.1	64	63	83	76	66.2	M
F1 Ventilation Blower	0.5		115 / 230	60	1.15	5.2 / 2.6		6.0 / 3.0							22.7 / 11.35	



# Wiring for F1 Ventilation Blower Unit

## Wiring and Motor Data



**! WARNING**

MOTOR MUST BE GROUNDED IN ACCORDANCE WITH THE NATIONAL ELECTRICAL CODE AND LOCAL CODE BY TRAINED PERSONNEL TO PREVENT SERIOUS ELECTRICAL SHOCKS.

TO SERVICE MOTOR, DISCONNECT POWER SOURCE FROM MOTOR AND ANY ACCESSORY DEVICES AND ALLOW MOTOR TO COME TO A COMPLETE STAND STILL.

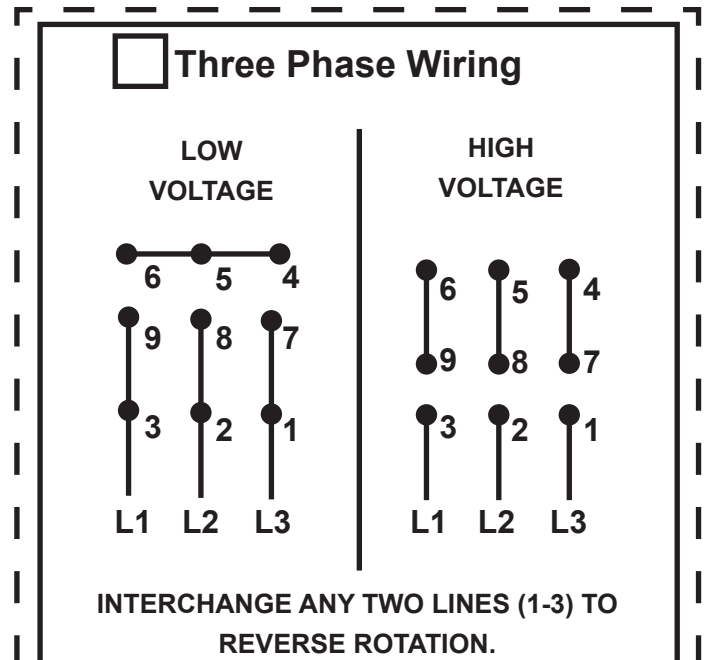
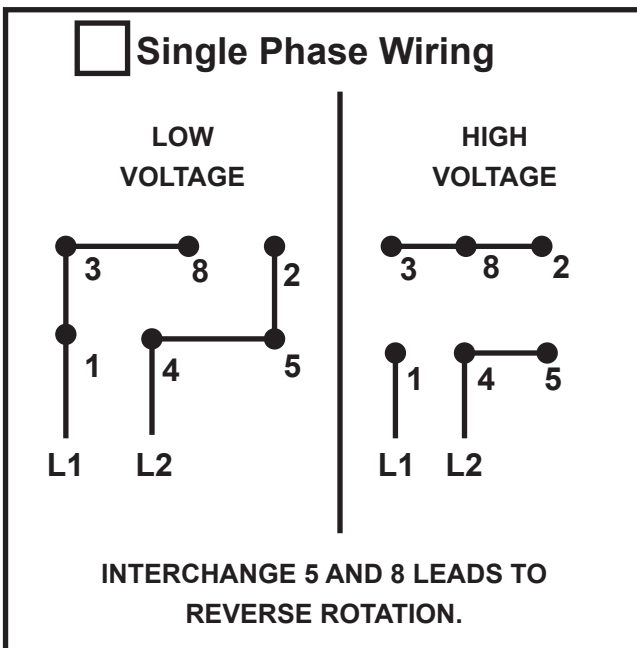
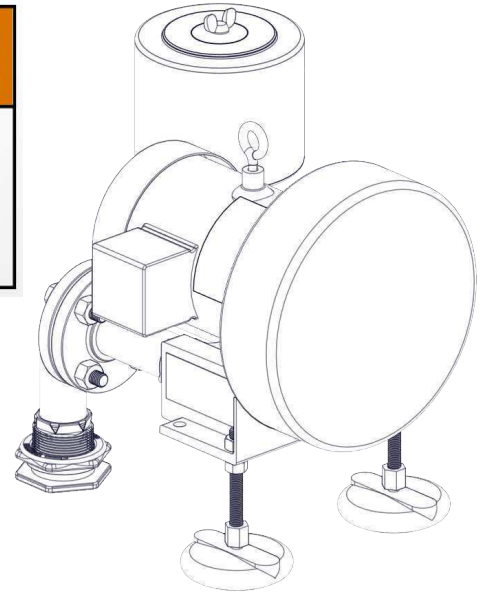

5.2 Amps @ 115VAC / 60HZ / 1-Phase  
Motor Resistance: 1.9 Ω

2.6 Amps @ 230VAC / 60HZ / 1-Phase  
Motor Resistance: 4.9 Ω

Service Factor: 1.15

1.8 Amps @ 208VAC / 60HZ / 3-Phase  
Motor Resistance: 11.5 Ω

1.6 Amps @ 230VAC / 60HZ / 3-Phase  
Motor Resistance: 11.5 Ω

0.8 Amps @ 460VAC / 60HZ / 3-Phase  
Motor Resistance: 43.0 Ω

Service Factor: 1.15

Custom - Special Order Item

# Assembly

## Penetration Detail

SN1 Electric & F1 Ventilation Blower Air

### Tools Required:

Cordless Drill, Lubricating Fluid, Catch Bucket, Cleaning materials for containing sealant and metal filings

### SN1 Electric Penetration

1. Locate 1-5/16" Hole Saw, Universal Fixture Assembly, and Lexel Tube from Package Contents
2. Determine penetration point that is within arms reach of the access hatch in the tank roof. Do not install below tank overflow water level.
3. Make sealed penetration referencing the following diagram:

#### T316SS UNIVERSAL FIXTURE: TANK PENETRATION ASSEMBLY

TANK PENETRATION IS SEALED WITH HDPE WASHERS ACCOMPANIED BY LEXEL® CO-POLYMER RUBBER-BASED SEALANT

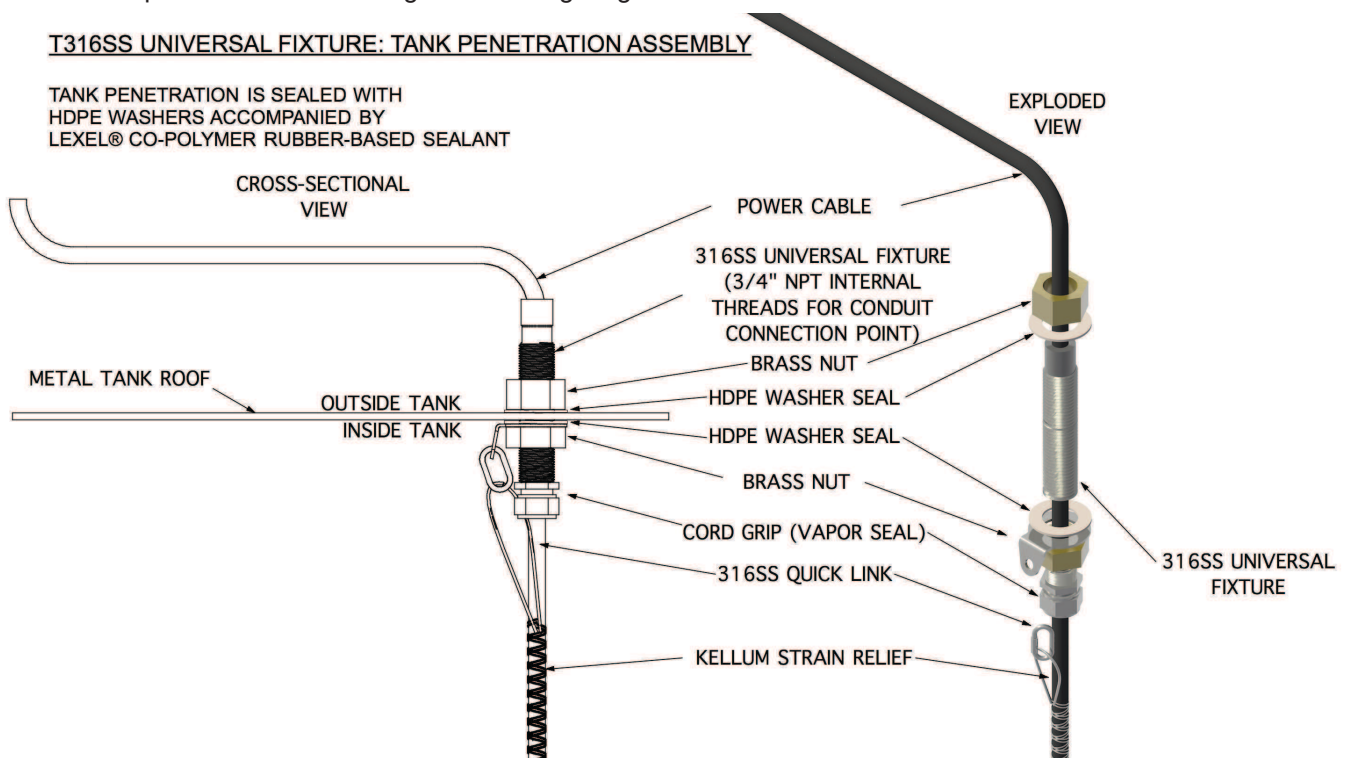

### F1 Ventilation Blower Air Penetration

1. Locate 2-1/2" Hole Saw, 1.25" Bulkhead Fitting, and Lexel Tube from Package Contents
2. Determine penetration point that is **A)** within arms reach of the access hatch in the tank roof and **B)** relatively close to directly above the SN1 Spray Unit position. Do not install below tank overflow water level.
3. Make sealed penetration referencing the following diagram:

#### T316SS BULKHEAD FITTING: AIR ENTRY FOR F1 VENTILATION BLOWER

TANK PENETRATION IS SEALED WITH EPDM GASKETS ACCOMPANIED BY LEXEL® CO-POLYMER RUBBER-BASED SEALANT

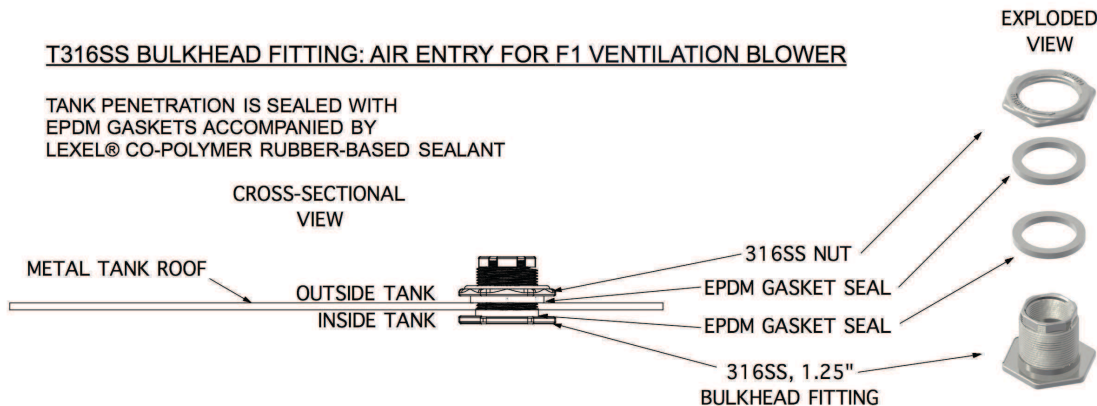

# Assembly

## Hose Connection

### SN1 Upper Hose and Torque Bar Lower Hose Connection

#### Tools Required:

Cordless Drill and 5/16" Nut Driver

#### SN1 Upper Hose Connection

1. Locate 6" Hose, 6" Hose Clamp, and SN1 Core Unit from Package Contents
2. Slide 6" Hose Clamp around one end of the 6" Hose
3. Slide that end of 6" Hose around motor and pump of SN1 Core Unit assembly
4. Continue sliding hose up until it is completely over and well past the flared out part of the SN1 Core Unit flange
5. With 6" Hose Clamp around 6" Hose and past flared out part of SN1 Core Unit, Tighten 6" Hose Clamp

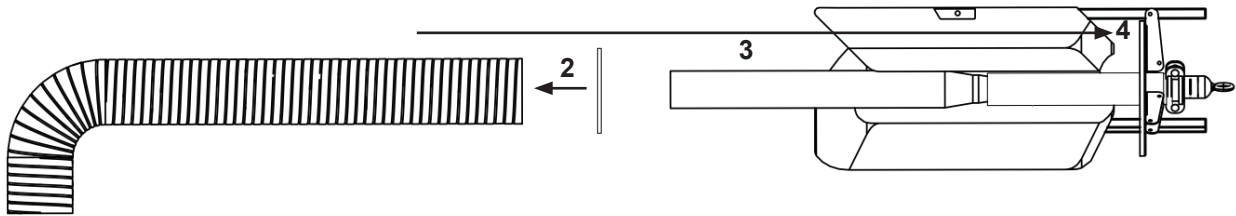

#### Torque Bar Lower Hose Connection

1. Locate 6" Hose Tube Insert, 6" Hose Clamp, and Torque Bar Assembly from Package Contents
2. Slide 6" Hose Tube Insert inside the the lower end of the 6" Hose until it is flush with the end
3. Open the 6" Hose Clamp up by loosening screw, slide it through either of the two slots on Torque Bar Assembly
4. Close the 6" Hose Clamp up by hand tightening screw.
5. Slide the 6" Hose Clamp over the end of the hose, so it is approximately centered over Tube Insert and tighten
6. Leave Torque Bar in the existing collapsed configuration until later when it is deployed through roof hatch

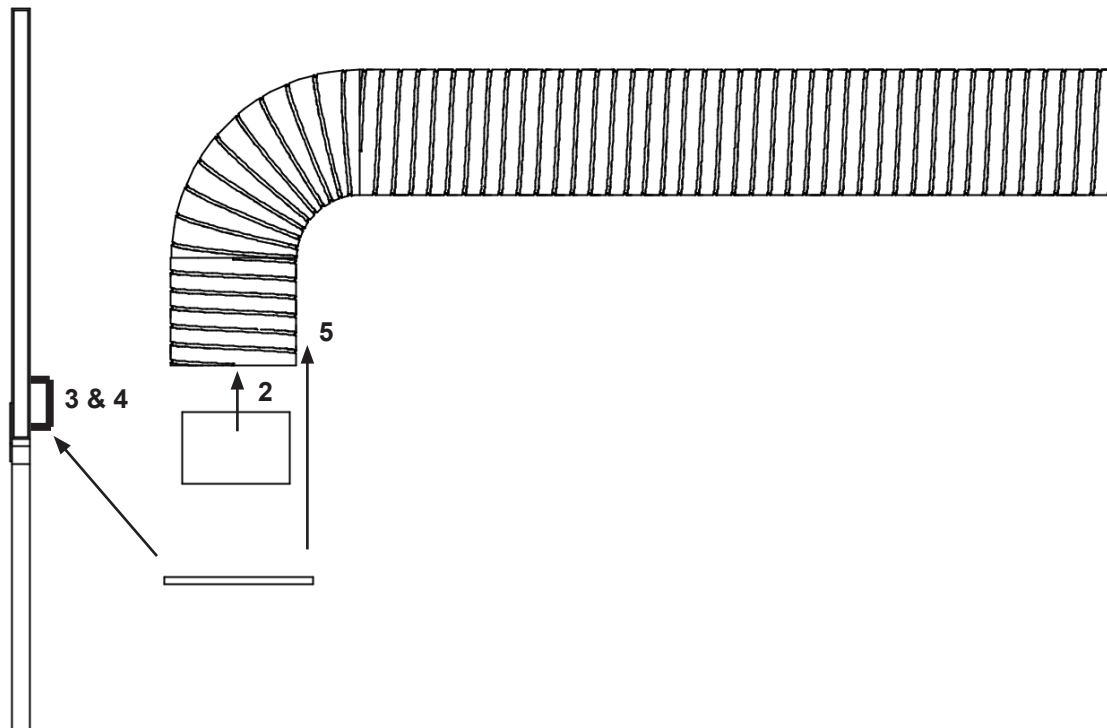

# Assembly

## Electric Cord Splice & Routing

### Tools Required:

Caulking Gun, Wire Stripper, Crimper, Pliers, and 13mm or 1/2" box end & socket wrench

### Electric Cord Splice

1. Locate SN1 Core Unit, Epoxy Splice Kit, Epoxy Tube, Kellem Grips, and Submersible Electric Cord from Package Contents
2. Locate the motor lead wires above the SN1 Core Unit, strip the wires to prepare them for crimp connection
3. At an end of the Submersible Electric Cord, slide one Kellem Grip a short distance down cord, then strip away the jacket & wires to prepare them for crimp connection
4. Match lead jacket colors, crimp wires together, and slide insulative cap over each crimp connection
5. Get caulking gun ready with epoxy tube and fill splice PVC pipe about 1/2 full with epoxy
6. Slide spliced connected wires/caps all the way inside to the bottom of PVC pipe, plunge up and down
7. Fill the remainder of the PVC pipe full with epoxy
8. Bolt bracket to SN1 Core Unit using M8 bolt in Epoxy Splice Kit
9. Avoid tipping upside down for 60 minutes or until set, then clamp PVC pipe to bracket with small hose clamp

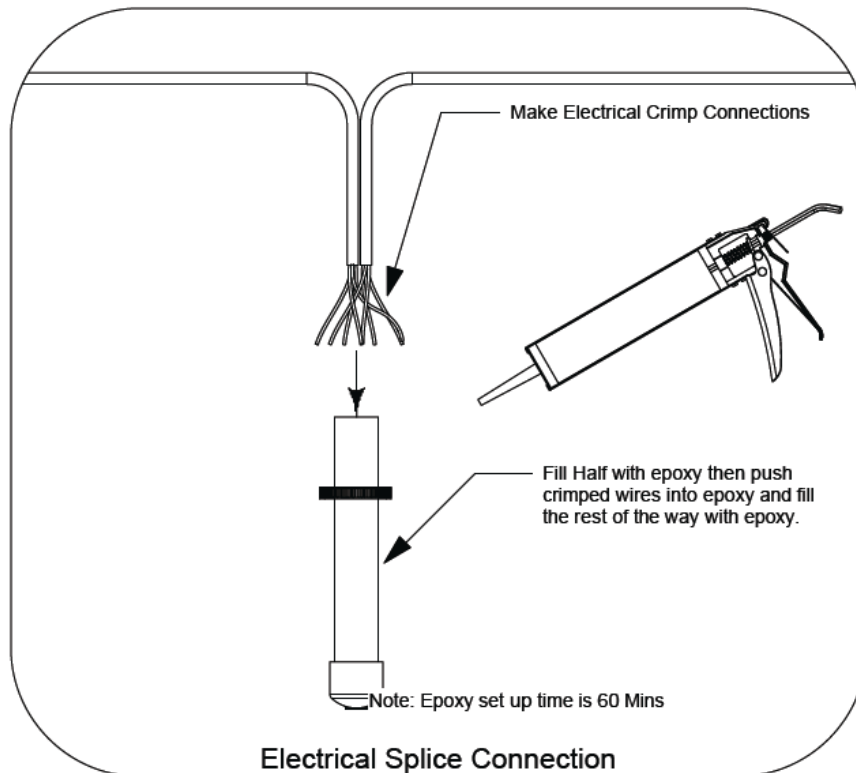

### Submersible Electric Cord (top side)

1. Loosen interior cord grip on the Universal Fixture and slide other kellem grip on opposite, non spliced end of Submersible Electric Cord.
2. When applicable, route the non-spliced end of the Submersible Electric Cord through the hatch, then up through cord grip and Universal Fixture Assembly, allowing plenty of extra length to splice to exterior power conductors at LB or Disconnect Box shown on Requirements Page.
3. Secure Kellem Grip to interior Universal Fixture Assembly using shared quick link with retrieval chain.

# Assembly

## Retrieval Chain Connection

### Tools Required:

Pliers

### Retrieval Chain Connection

1. Locate Retrieval Chain, Quick Link, and SN1 Core Unit from Package Contents
2. Connect end of Retrieval Chain to Eyelet at the very top of the SN1 Core Unit by making a small loop and using Quick Link to secure the loop of chain.
3. Run opposite end of Retrieval Chain through roof hatch and connect to the interior side of Universal Fixture using quick link.

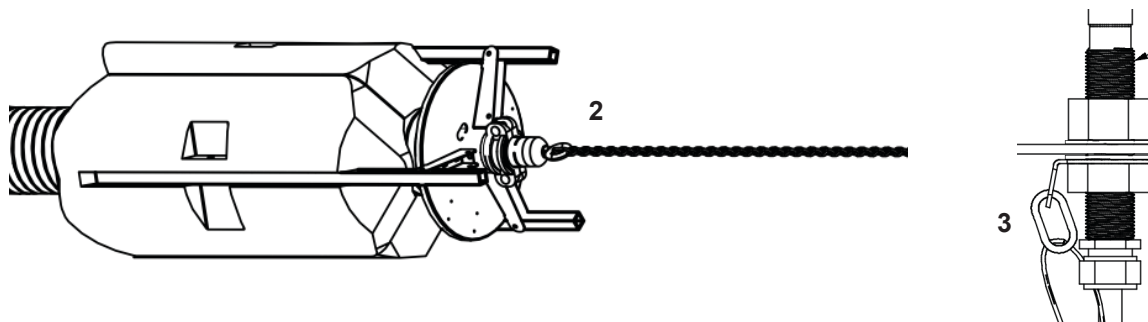

# Assembly

## Interior Assembly (After Fitting Through Hatch)

### Tools Required:

13mm or 1/2" box end & socket wrench

### Interior Assembly (After Fitting Through Hatch)

The SN1 Unit at this point is ready to be deployed, but it's important to make a lowering/support plan, because there are two interior assembly procedures that need to take place:

1. When the Torque Bar Assembly at the bottom of the hose is just through the hatch, it needs to be expanded into its cross configuration. This involves:  
**A)** Removing an existing M8 bolt/nut, **B)** Expanding Torque Bar, then **C)** Reinserting/Tightening the M8 bolt/nut
2. When the Collapsed SN1 Core Unit's Floats just pass all the way through the hatch, they each need to be:  
**A)** expanded all the way out until the square tubing is set inside the float arm channel, **B)** Insert the Float Lock Pin and Hair Pin to secure the float in the expanded configuration, **C)** Repeat for other two Floats.

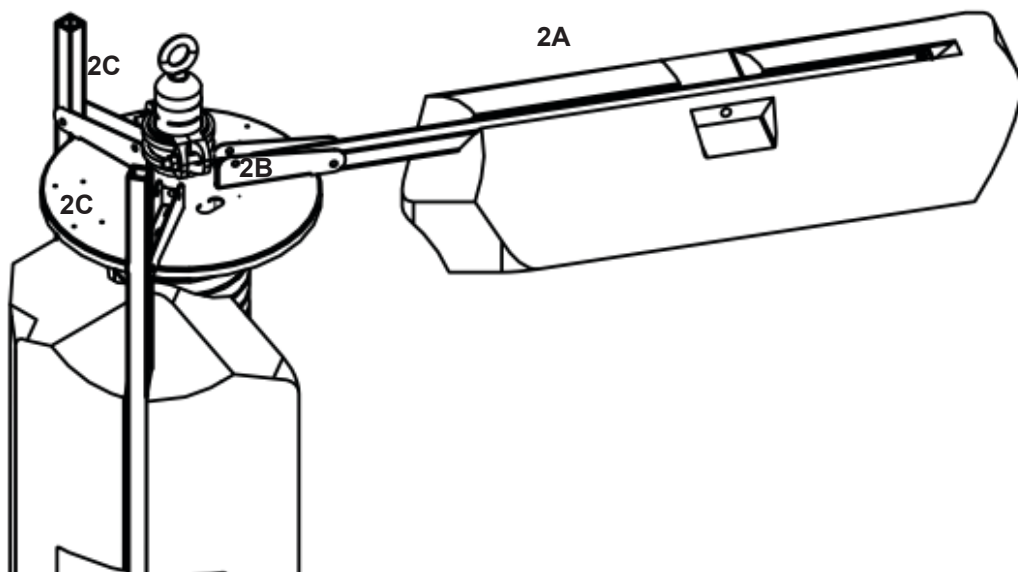
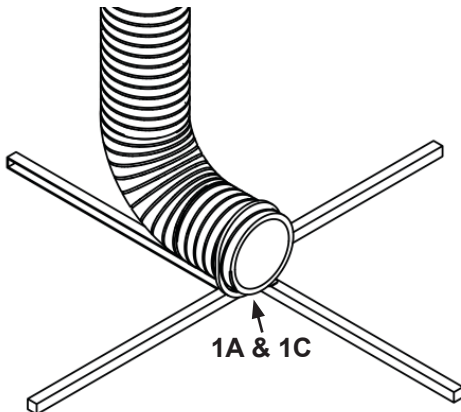



# Assembly

## F1 Ventilation Blower Unit Mounting

### Tools Required:

Pipe Wrench, Channel Locks, 19mm or 3/4" box end & socket wrench

### Blower Mounting

1. Locate F1 Ventilation Blower Unit, 1.25" Flanged Elbow Pipe, Flange Gasket, Flange Bolts, Nuts, Washers, and Anti-Sieze Tube from the Package Contents
2. Mark out a location for the F1 Ventilation Blower Unit to reside in its final position (24" L X 12" W X 18" H Required)
3. Apply anti-sieze to the threads of the 1.25" Flanged Elbow Pipe and thread it into the 1.25" Bulkhead Fitting on the tank roof. Tighten the Flanged Elbow Pipe so that the flange is facing the direction of the final F1 Ventilation Blower position determined
4. Position the F1 Ventilation Blower so that the flanges are close to aligning. Make final alignment adjustments by moving the nuts on the two threaded rod feet
5. Insert the Flange Gasket in between the flanges, then secure the flanges using the bolts, nuts and washers
6. Finish by tightening the threaded rod nuts so that the two feet are snugly pushing against the tank roof

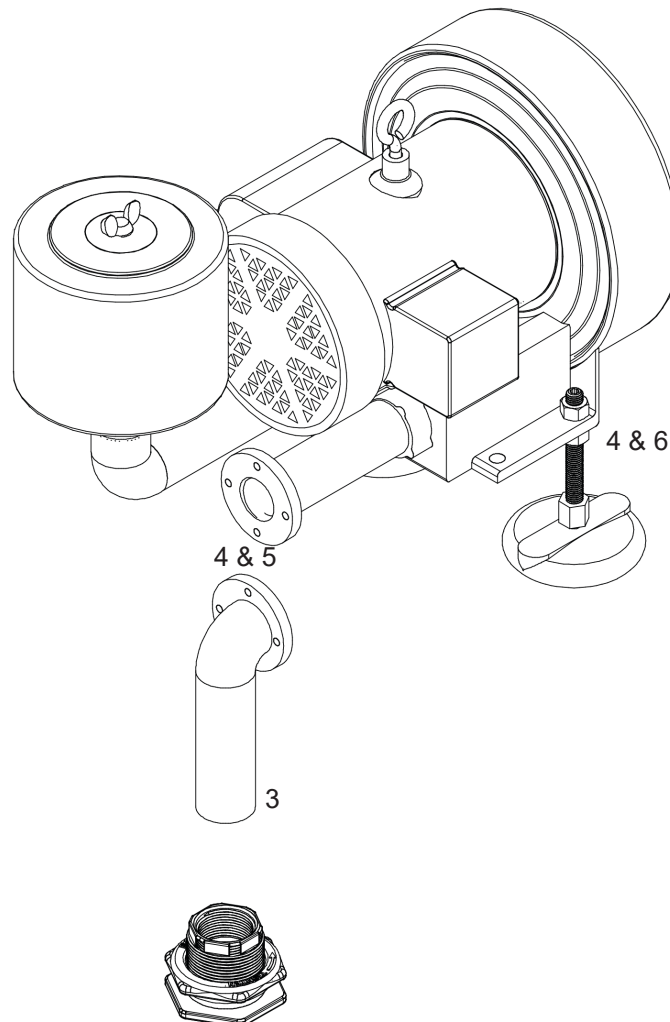

# Final Checklist

# Final Checklist

## SN1

### Installation Checks

Before starting the SN1 Spray Unit and F1 Ventilation Blower Unit, a few checklist items are recommended to confirm the installation is correct.

Installation Checks	Check
Is the SN1 floating properly with all three floats expanded out? (Assembly)	
Is the SN1 retrieval chain connected securely? (Assembly)	
Is the kellum grip supporting the weight of the cord? (Assembly)	
Is the cord ran through the cord grip and sealed off at the bottom of the Universal Fixture (Assembly)	
Are the Universal Fixture and 1.25" Bulkhead penetrations properly sealed? (Assembly)	
Are the top of tank electric splices correct and each splice individually sealed to protect from corrosion? (Assembly)	
Is the field wiring correct? (Requirements)	
Is The Mixer submerged in at least 4' (1.2m) of water?	

Pre Operation Checks	Reading	
Continuity Check	Black to White:	
Discontinuity Check	White to Ground:	
	Black to Ground:	
Source Voltage Reading		

### Operation Checks

The following checklist items are recommended to confirm proper operation.

Operation Check (While Unit is Running)	Reading / Observation
Source Voltage Reading	
Amperage Reading	
Spray/Air Check Auditory	
Spray/Air Check Visual	



# Operation

# Operation

## SN1 Spray Unit & F1 Blower Unit

### Operation SN1:

#### Motor Amperage

When the SN1 is operating at peak performance, the motor amperage will be in between full and max load of the rated motor current. The following table can be referenced for a SN1 Spray Unit.

HP	Voltage	Typical Full Load Amperage
1.5	230vAC 1-Phase	11.0 to 13.5 Amps

#### Amperage Readings Below Full Load Amperage

If amperage readings are significantly below the Typical Full Load Amperage, it may be indicating that there is an excessive restriction to the water flow of the machine or that the submersible pump is no longer performing optimally. For low motor amperage, check that there is not blockage of the center nozzle opening for each of the multiple nozzle heads.

#### Amperage Readings Above Full Load Amperage

If amperage readings are significantly above the Typical Full Load Amperage, it may indicate that the pump screen is blocked with large debris or that the nozzle assembly has worn openings and requires replacement. The pump and motor assembly can be removed from the floating frame assembly for inspection.

For very high motor amperage or tripping breaker, additional checks may be required, such as measuring voltage, current, and taking resistance readings for the electric power leads and motor windings.

### F1 Blower Operation

#### Motor Amperage

When the 1/2HP Blower is operating at peak performance, the motor amperage will be in between full and max load of the rated motor current. The following table can be referenced for a 1/2HP Blower Unit.

HP	Voltage	Typical Full Load Amperage
0.5	230vAC 1-Phase	1.5 to 2.6 Amps

#### Amperage Readings Outside Normal

If amperage readings are not within range, it may be indicating that there is an excessive restriction to the air flow of the machine or that the blower is no longer performing optimally. For low motor amperage, check the air filter for restriction and clean or replace as necessary. The **Replacement Air Filter Element** is readily available by searching for the following make and model number: **SOLBERG 19P**

For very high motor amperage or tripping breaker, additional checks may be required, such as measuring voltage, current, and taking resistance readings for the electric power leads and motor windings.

# Technical Data Sheet

## SN1

**Technology Description-** Floating, electric powered, circulation and Trihalomethane (THM) removal equipment for potable water tanks and reservoirs. Designed for continuous operation and placement through 18-inch diameter (46 cm), minimum clear roof opening.

**Materials of Construction** - T316 stainless steel, thermoplastic rubber, High Density Polyethylene construction. GridBee® Machines are constructed using safe materials for contact with potable water. See certifications section below.

**Spray Unit Direct Flow Rate** - 75,000 Gallons Per Day, GPD. *Ixom application engineering evaluations often require sizing systems based on site specific conditions and NOT the spray aeration direct flow rate.*

**Minimum Access Opening** - Machine can be placed through 18 inch (46 cm) diameter opening.

**Minimum Water Depth** - Minimum of 48 inch (1.2 m) operating depth required, do not operate out of water.

**Minimum Head Space** - Minimum of 19 inch (50 cm) head space between water level and reservoir/tank ceiling required.

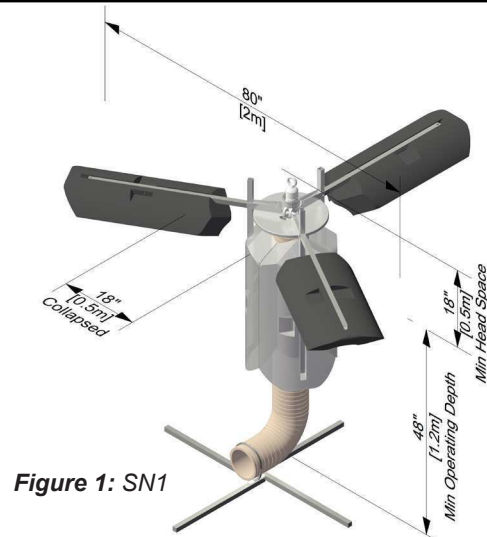

Figure 1: SN1

**Intake** - 20 to 100+ feet (6 to 30+ m) available in 6 inch (15.3 cm) diameter X 20 feet (6 m) sections, thermoplastic rubber, NSF/ANSI 61 approved. Includes low elevation inlet that draws water in a horizontal layer within 6 inches (15 cm) of the tank or reservoir floor. Includes intake retrieval chain constructed of 316 stainless steel.

**Electrical Requirements** - Requires 230vAC, 1-PH, 60Hz power. 208v 3-PH available by special request. Ixom recommends secondary disconnect to be located near equipment access hatch. Optional 1-phase control panel operates both SN1 Spray Unit and Blower. *All switches, breakers, emergency stop buttons, control panels and other controls shall be installed in accordance to all NEC, State, and local regulations. (Not supplied by Ixom.)*

**SN1 Motor** - 1.5HP stainless steel submersible, designed for continuous operation, low power requirement, direct drive, no gearbox and no lubrication schedule required. See certifications section below.

**SN1 Wiring** - 3-conductor, submersible power cable for submersible motor wiring terminated exterior at top of tank.

**Sealed Penetration Fitting** - T316 stainless steel tank fitting with a 3/4" NPT female connection. Not designed as a submersible penetration.

**Blower Motor** - 0.5HP TEFC motor, designed for continuous operation, low power requirement, direct drive, no gearbox and no lubrication schedule required.

### Shipping Size / Weight

- **Crate** - 72 inch x 48 inch x 48 inch (1.85 m x 1.22 m x 1.22 m) / 400lbs (185 kg) *Exact weight and dimensions varies dependent on machine configuration.*

**Certifications** - Ixom's potable water products are certified to NSF/ANSI/CAN 61-G & 372 for lead-free content. Learn more at: [www.ixomwatercare.com/std61](http://www.ixomwatercare.com/std61)

**Maintenance / Warranty** - Limited maintenance. Limited 2-year parts and labor warranty. See Warranty Statement for details.

## F1 Ventilation Blower

**Technology Description**- Single Stage Ventilation Blower with electric motor. Filtered air intake, distributes air inside tank for ventilation of tank head space, designed to evacuate volatilized THM's, gases and other contaminants from the head space. Features 1.25" bulk head tank connection and supported by 2 adjustable self-leveling feet.

**Part Numbers** - 100535 (single-phase)  
100439 (three-phase)

**Materials of Construction** - T316 stainless steel, power coated steel, EPDM construction.

**Air Filter** - 99%+ removal efficiency to 5 micron, pleated polyester air filter rated for 100 CFM (2.8 m<sup>3</sup>/min), 1.5 ft<sup>2</sup> surface area, washable, epoxy coated steel wire reinforcement on both sides. Molded plastisol endcaps. Dimensions: 3" ID, 4.38" OD, 4.75" H. PN: 20012058

**Air Flow Rate** - 60 cfm max rated at 60Hz, 50 cfm max rated at 50Hz.

Blower Performance (SCFM) at varying Static Pressures (Inches of Water)						
0"	1"	2"	3"	4"	5"	6"
60	59	58	57	56	55	54

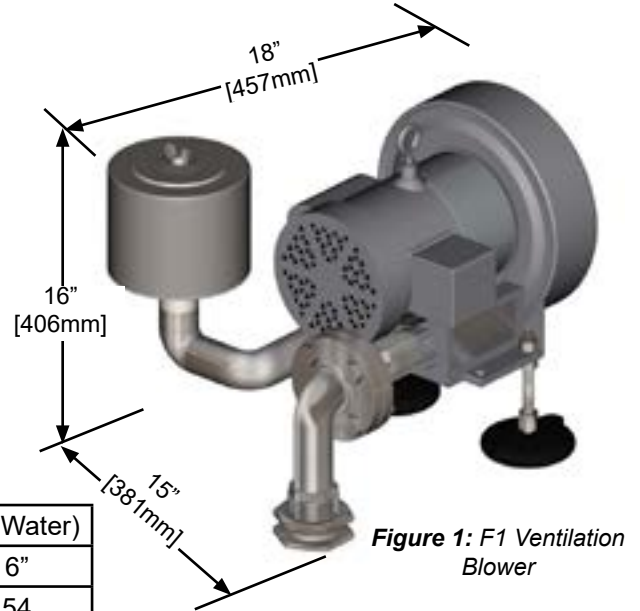

**Vibration Isolation** - Secured to T316SS bulk head fitting, supported by self-leveling dampening feet, constructed of glass-reinforced nylon with elastomer pad for anti-skid and light-duty vibration control applications.

**Sealed Tank Penetration** - Gasketed 1.25" NPT bulk head fitting, T316 stainless steel, tank fitting with a 2-1/2" diameter tank roof penetration required for air entry. Penetration sealed with LEXEL rubber-based sealant and rubber gasket to maintain integrity of the tank. Not designed as a submersible penetration.

**Electrical Requirements** - Requires 120VAC or 240VAC for single-phase units, and 208-240VAC or 480VAC for special order three-phase units, 60Hz power. Each motor is dual voltage and can be wired for either low or high voltage. Ixom recommends secondary disconnect to be located near blower equipment. *All conduit, conductors, switches, breakers, emergency stop buttons, control panels and other controls shall be installed in accordance to all NEC, State, and local regulations. (Not supplied by Ixom)*

**Motor** - 1/2HP TEFC induction motor, designed for continuous operation, low power requirement, direct drive, no gearbox and no lubrication schedule required. No heater. Estimated 66dba at 1.5m, 60Hz.

**Motor Bearing** - bearings filled with low-noise, low-friction grease, lubricated for life and are maintenance-free. The grease life is considered L10. (-20°F, +300°F)

**Wiring** - 3-conductors required for single-phase motors. 4-conductors required for special order three-phase motors. Electrical conduit body mounted to motor housing for conduit connection and electrical splicing.

### Shipping Size / Weight

- **Crate** - 20in x 20in x 20in (50.8cm x 50.8cm x 50.8cm) / 35lbs (15.8kg).

**Maintenance / Warranty** - Limited maintenance. Limited 1-year parts only. See GridBee THM Removal Systems Limited Replacement Warranty for more details.

Subject to change without notice.

# Dimension Drawing

## F1 Ventilation Blower

Dimension Drawing (P/N: 100536)

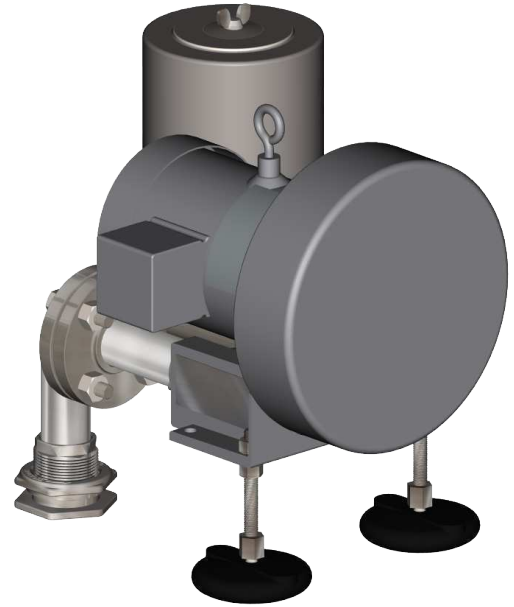
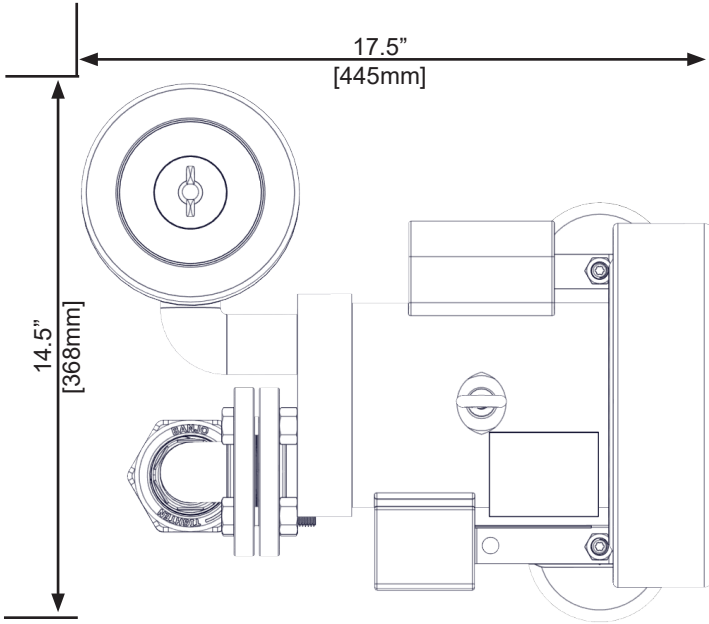

Filter Replacement:  
SMI Model 19P  
(P/N: 20012058)

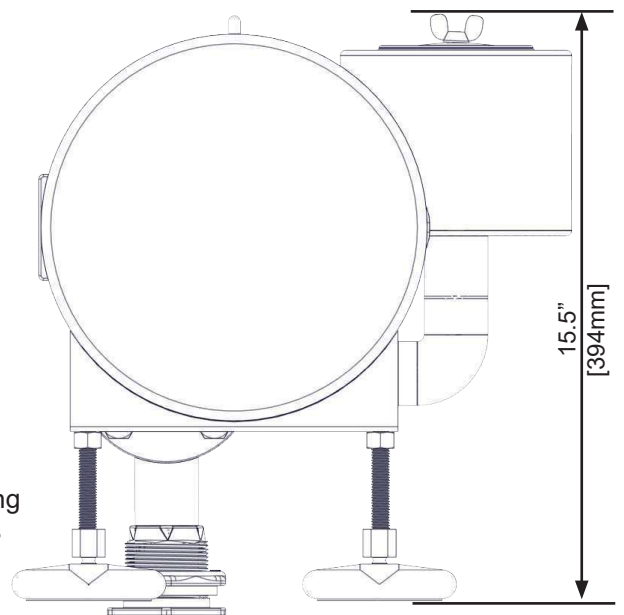
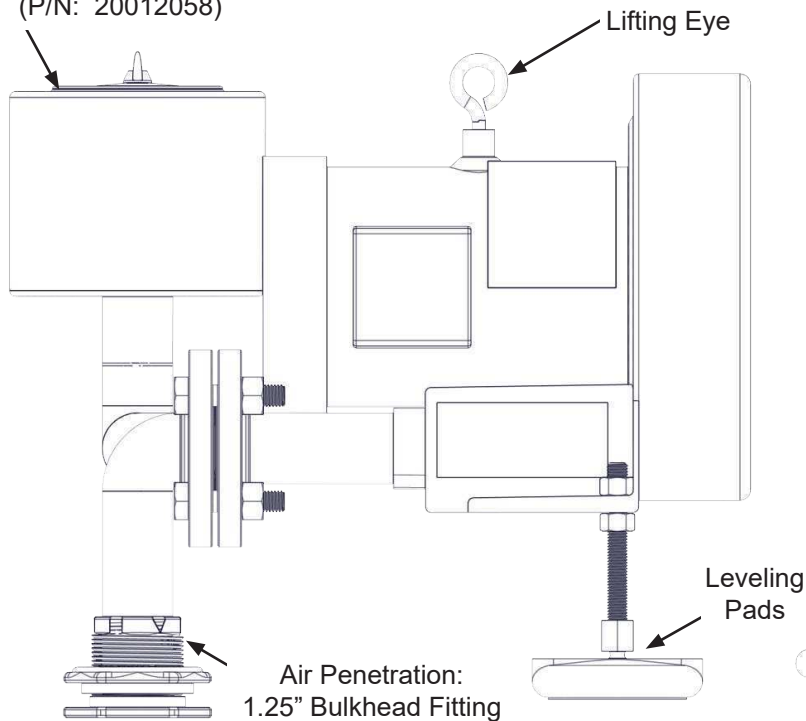

# Exploded Parts Diagram

## SN1

### Exploded Parts Diagram

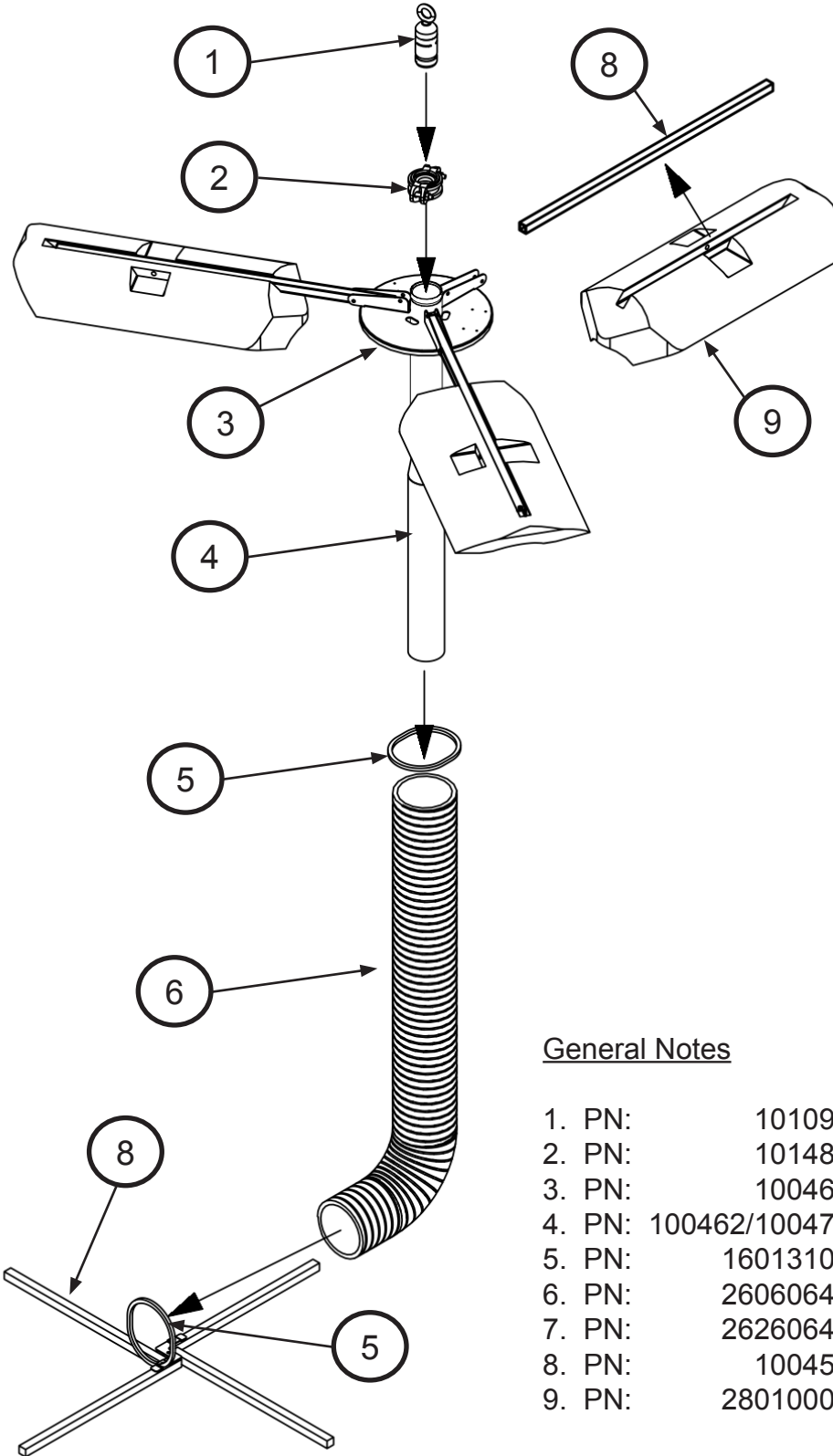

#### General Notes

1. PN: 101091 - SN1 3DX Nozzle Assembly
2. PN: 101486 - Groove Coupling, 2"
3. PN: 100461 - Floating Platform Assembly
4. PN: 100462/100478 - SN1 Submersible Pump/Motor
5. PN: 16013107 - 6" Hose Clamp
6. PN: 26060640 - 6" NSF Hose
7. PN: 26260640 - Cross Torque Bar Assembly
8. PN: 100459 - SN1 Float Arm
9. PN: 28010000 - Collapsible Float

# Dimension Drawing

## SN1

### Dimension Drawing

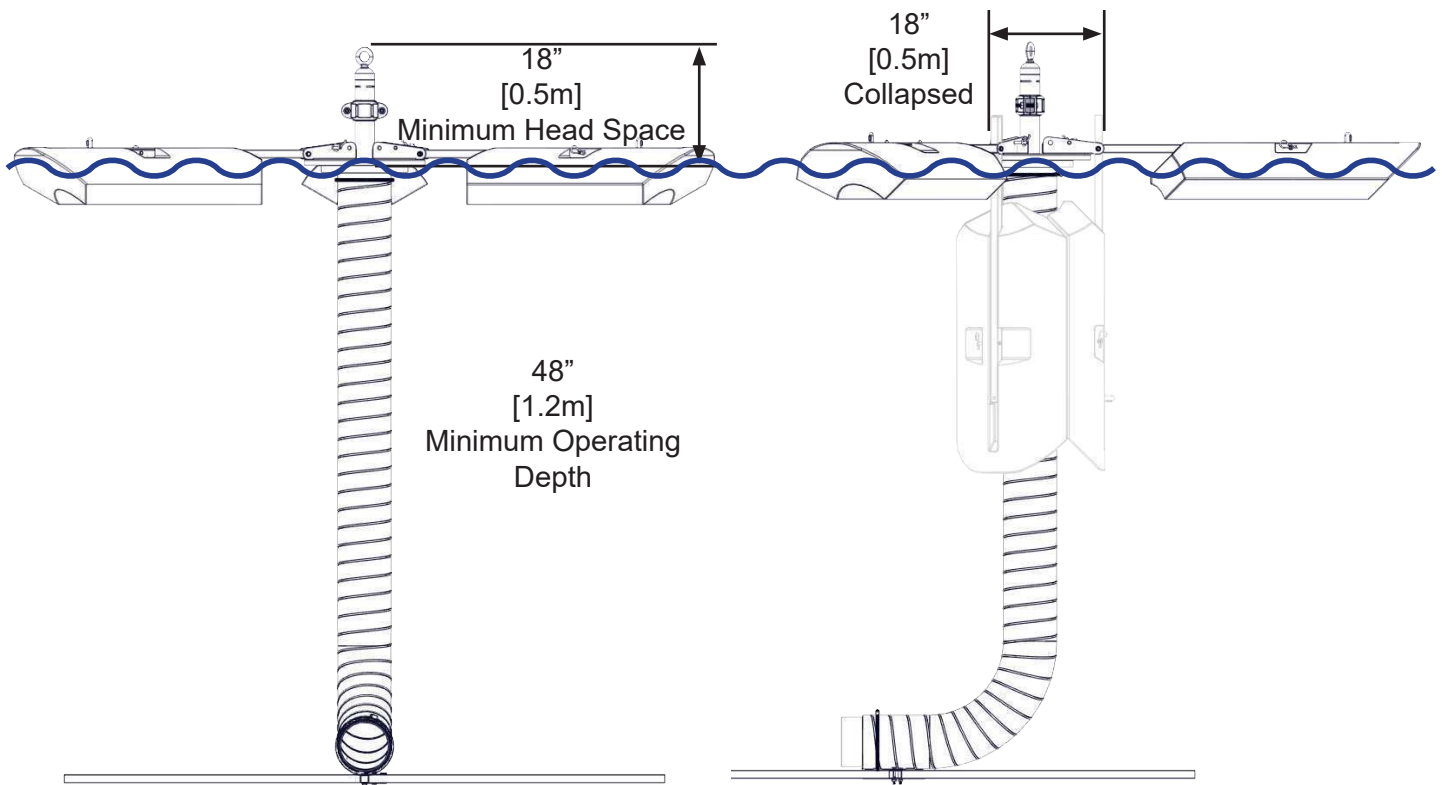
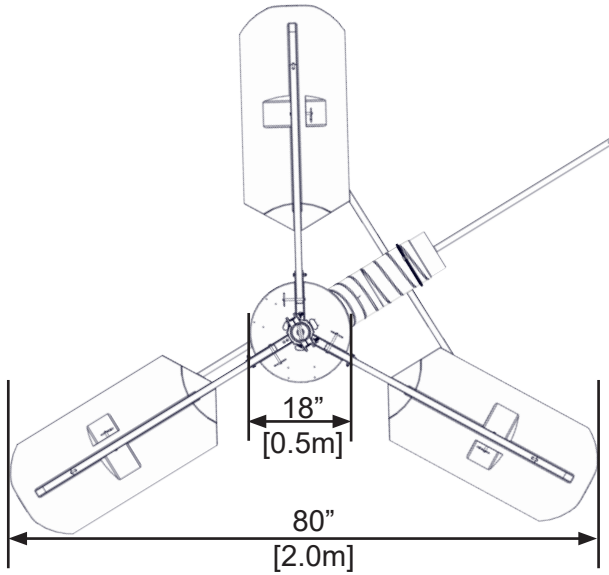



## Warranty



# GridBee THM Removal Systems

## Limited Replacement Warranty

**GridBee SN Spray Units.** GridBee SN Spray Units and blowers are warranted to be free of defective parts, materials, and workmanship for a period of two years from the date of purchase. The optional control panels, by other manufactures, are covered by a manufacturer's warranty of one year from date of purchase. This warranty is valid only for use of the GridBee THM Removal System in accordance with the owner's manual and any initial and ongoing factory recommendations. This warranty is limited to the repair or replacement of defective components only and does not apply to normal wear and tear. If the factory's service crews performed the original on-site placement and startup, then this warranty also includes labor. Where labor is included, in lieu of sending a factory service crew to the site for minor repairs, Ixom may choose to send the replacement parts to the owner postage-paid and may pay the owner a reasonable labor allowance, as determined solely by Ixom, to install the parts. There is no liability for consequential damages of any type. The warranty that is submitted and provided with the purchased equipment is the valid warranty.

**GridBee control panels, and any optional accessories.** These items are considered "buyout" items for Ixom, and as such include a warranty against defects in material and workmanship for one year from the date of purchase. This warranty covers parts only, not labor. Parts that are determined by Ixom to be defective in material or workmanship under normal use during the one year warranty period will be repaired or replaced. Shipping charges are the responsibility of the customer.

**Terms applicable to all equipment.** This Limited Replacement Warranty is subject to the terms of Ixom's General Terms and Conditions of Sale. In the event of any inconsistency between the terms of this Limited Replacement Warranty and Ixom's General Terms and Conditions of Sale, the terms of this Limited Replacement Warranty shall prevail to the extent of that inconsistency.

# Protect Your Investment With The Ixom Service Program

## Comprehensive Damage Repair

Damage which occurs to your Ixom manufactured equipment in the normal course of operation will be repaired or replaced including supply and installation of structural repairs and replacement parts in accordance with Ixom's standard terms & conditions.

## Trained & Experienced Service Technicians

The Ixom Service Program allows our customers to take advantage of our highly trained service technicians. We have the equipment, experience and training to ensure the machines are well maintained while following OSHA regulations. Our dedication to safety and high level of training has earned us the prestigious SHARP recognition award time and time again. We have the means to safely service the equipment whether in municipal water tanks, lakes, reservoirs, or wastewater ponds & basins.



## Guaranteed Annual Onsite Maintenance

Ixom service personnel will perform a minimum of one (1) onsite equipment inspection & maintenance per yearly term of the service contract including mechanical, structural, and electronic components of Ixom manufactured equipment.

## On-Site Crew Response for Critical Application and Operational Service Issues

If service issues arise, the customer may be asked to perform a basic machine inspection and discuss results with Ixom's Customer Service Department. In some cases, the customer may be asked to perform minor tasks (i.e., cleaning, basic troubleshooting, and replacing minor parts). If replacement parts are needed, the factory will ship them out at no cost. For more serious application and service issues, Ixom will dispatch service personnel to resolve the issues onsite.



## Removal, Storage, and Redeployment of Equipment

For situations when Ixom equipment needs to be removed, stored, and redeployed, services can be offered at a discounted rate.

## Access to On-Staff Water Quality Experts

Ixom employs many experts in the water quality field including specialized areas such as limnology, hydrology, wastewater, biology, and engineering. Our water quality personnel are available for data analysis and troubleshooting when you need it.



## Contact us for a quote!

Call +1 866-437-8076 or email us at [watercare@ixom.com](mailto:watercare@ixom.com)



# IXOM

## WATERCARE

## Nationwide Installation & Service

### EVERYONE DESERVES GREAT CUSTOMER SUPPORT

Ixom Watercare earns customer trust with unparalleled service start to finish. Every department in Ixom is dedicated to the support of our Customers and the improvement of water quality. Complete life cycle support is much, much more than a returned phone call or an email. It centers around direct access and communication to those who can help when help is needed from the beginning of a project throughout the life of the equipment.

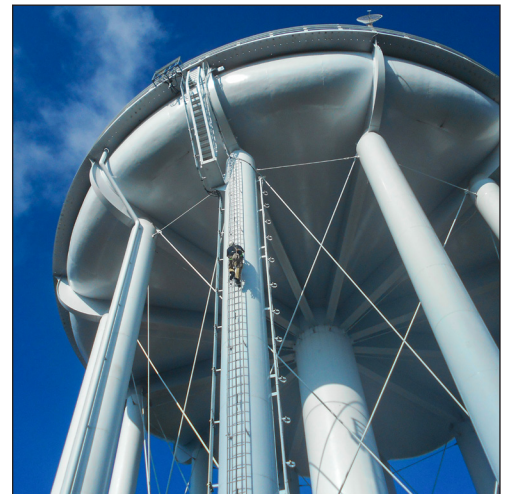

### ABOUT IXOM

Ixom combines innovative water quality solutions with top notch manufacturing and nationwide in-field service capabilities to create trusted, full circle support our Customers depend on.

We design and manufacture many trusted brands including GridBee®, SolarBee®, MIEX®, and ResidualHQ® for use across the water quality spectrum. This includes solutions for Water Treatment, Distribution Treatment, Wastewater Treatment and Lakes & Source Water Reservoirs.

Ixom has thousands of installations and is an industry-leader solving water quality problems across the United States, Canada and the world.

**Contact us today to discuss your water quality and service needs.**

[ixomwatercare.com](http://ixomwatercare.com)  
866-437-8076 • [watercare@ixom.com](mailto:watercare@ixom.com)