

# GridBee GF10000

## Owner's Manual



# Table of Contents



## GridBee GF10000

### Owner's Manual

---

Safety	1
Operation	4
Features	5
Assembly	14
Maintenance	21
Electrical	27
Troubleshooting	29
Parts Diagram	32
Dimension Drawing	33
Appendix	34
Technical Specifications	35
Warranty	41
Service Program	42
Customer Service	43

---

## Safety

# IMPORTANT

**YOU MUST COMPLETELY  
READ AND FULLY  
UNDERSTAND THESE  
INSTRUCTIONS BEFORE  
INSTALLING, OPERATING,  
OR SERVICING THIS UNIT.**

**Be sure you have read all installation, operation, maintenance and safety instructions before you install, service or begin to operate this unit.**

Accidents occur every year because of careless use of industrial equipment. You can avoid hazards by following these safety instructions, and applying some ordinary common sense when operating or servicing this unit.

Keep in mind that **full operator attention and alertness** are required when operating or servicing this unit.

**USE COMMON SENSE!!** Most accidents can be avoided by using **common sense and concentration** on the job being done.



Carefully read safety information when you see any safety symbols.



# Safety

## IMPORTANT

**YOU MUST COMPLETELY READ AND FULLY UNDERSTAND THESE INSTRUCTIONS BEFORE INSTALLING, OPERATING, OR SERVICING THIS UNIT.**

Identify all possible hazards. Determine what safeguards are needed and implement them. **Only you, the user,** understand your product and system characteristics fully. *The ultimate responsibility for safety is with you. Your safety ultimately rests in your hands.* Do your part and you will enjoy safe, trouble free operation for years to come. This instruction manual is not intended to include a comprehensive listing of all details for all procedures required for placement, operation and maintenance. If you have a question about a procedure or are uncertain about any detail, **Do Not Proceed.** Please contact Ixom Watercare Customer Service at **866-437-8076** to speak to a representative.



### **IMPORTANT!!!**

Follow all federal and state laws in regards to safety regulations of working at heights, confined spaces, rescue, etc. as required by the U.S. Department of Labor, Occupational Safety and Health Administration. Use necessary PPE when placing and servicing this unit.



### **Thin Ice Hazard**

**WARNING:** ICE SURROUNDING MACHINE MAY NOT SUPPORT WEIGHT, KEEP CLEAR OF THIN ICE.



### **ELECTRICAL HAZARD**

**WARNING:** THIS EQUIPMENT CONTAINS HIGH VOLTAGE! ELECTRICAL SHOCK CAN CAUSE SERIOUS OR FATAL INJURY. ONLY QUALIFIED PERSONNEL SHOULD ATTEMPT PLACEMENT, OPERATION AND MAINTENANCE OF ELECTRICAL EQUIPMENT. REMOVE ALL SOURCES OF ELECTRICAL POWER BEFORE PERFORMING ANY SERVICE WORK TO THE MACHINE. USE PROPER LOCKOUT TAGOUT (LOTO) PROCEDURES TO ENSURE A SAFE WORK ENVIRONMENT.



### **Crush Hazard**

**WARNING:** DO NOT REMOVE ANY FLOAT ASSEMBLY BOLTS OR PINS WHILE EQUIPMENT IS FLOATING IN WATER. EQUIPMENT MUST BE SECURELY SUPPORTED BEFORE PERFORMING SERVICE.



### **Rotating Hazard**

**CAUTION:** KEEP BODY APPENANDAGES OR LOOSE CLOTHING AWAY FROM EQUIPMENT WHILE OPERATING. ENSURE EQUIPMENT IS OFF BEFORE ATTEMPTING SERVICE.



### **Entanglement Hazard**

**WARNING:** ENSURE THAT PERSONNEL ARE CLEAR OF THE ELECTRIC CORD AND CHAIN TO AVOID ENTANGLEMENT.



### **Laceration Hazard**

**CAUTION:** EDGES MAY BE SHARP AND CAUSE LACERATION IF PROPER CARE IS NOT USED.



# Safety

## Protect Yourself

It is important that you comply with all relative OSHA and local regulations while installing and performing any maintenance to the mixer circulation equipment.

Key OSHA Compliance Standards that must be followed (and not limited to) are:

- **1910.146 Permit-required confined spaces**
- **1910.147 Lockout/Tagout**
- **1926.500 Fall Protection**

## Fall Protection Tips

- Identify all potential tripping and fall hazards before work starts.
- Look for fall hazards such as unprotected floor openings/edges, shafts, open hatches, stairwells, and roof openings/edges.
- Inspect fall protection and rescue equipment for defects before use.
- Select, wear, and use fall protection and rescue equipment appropriate for the task.
- Secure and stabilize all ladders before climbing.
- Never stand on the top rung/step of a ladder.
- Use handrails when you go up or down stairs.
- Practice good housekeeping. Keep cords, welding leads and air hoses out of walkways or adjacent work areas.

Refer to 29 CFR 1926.500 for complete regulations set by OSHA. Refer to your state's regulations if your state established and operates their own safety and health programs approved by OSHA.

## Lockout Tagout

When the On/Off switch is in the "ON" position, the mixer may start up at any time if not already operating. The mixer's On/Off switch can be locked out by placing a pad lock thru the door latch of the controller after the switch has been turned to the "OFF" position. The On/Off switch is to be used as the emergency stop.



## Permit-Required Confined Spaces

A confined space has limited openings for entry or exit, is large enough for entering and working, and is not designed for continuous worker occupancy. Confined spaces include underground reservoirs, ground storage tanks, elevated tanks, silos, manholes, and pipelines.

## Confined Space Tips

- Do not enter permit-required confined spaces without being trained and without having a permit to enter.
- Review, understand and follow employer's procedures before entering permit-required confined spaces and know how and when to exit.
- Before entry, identify any physical hazards.
- Before and during entry, test and monitor for oxygen content, flammability, toxicity or explosive hazards as necessary.
- Use fall protection, rescue, air monitoring, ventilation, lighting and communication equipment according to entry procedures.
- Maintain contact at all times with a trained attendant either visually, via phone, or by two-way radio. This monitoring system enables the attendant and entry supervisor to order you to evacuate and to alert appropriately trained rescue personnel to rescue entrants when needed.

Refer to 29 CFR 1910.146 for complete regulations set by OSHA. Refer to your state's regulations if your state established and operates their own safety and health programs approved by OSHA.

## Operation

# Operation

## GF Series

The GridBee is designed to circulate water by bringing water from below and sending it out across the top in a thin layer causing a mixing effect. The laminar layer flows outward radially, in diverging “stream lines” from the distribution dish. As it does, vertical flow is induced in between the water being drawn below and the water above. At the level of the flow intake, water is drawn from all corners of the pond. As this lower layer of fluid makes its way inward with converging streamlines to the GridBee, the water is forced upward, toward the surface, providing gentle mixing, de-stratification, and surface renewal.

The GF series GridBee requires a minimal amount of AC grid-power. The grid provides power to the onboard AC:DC power box and motor controller that drive the brushless motor. The GF Technology allows the GridBee to operate during day and night while drawing minimal amount of power from the grid.

During operation, a visible flow can be observed coming off the distribution dish and spreading outward. The motor and impeller is designed to operate at the same full speed as the solar-powered SolarBee models.

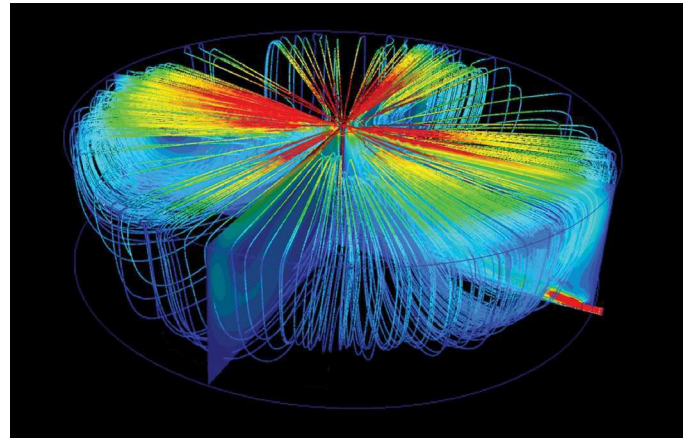

*GridBee Flow Pattern*



*Flow Coming Off Distribution Dish*

## Features

## Features

### SB and GF Large Frame Mixers

SCADA outputs offering machine operation parameters reside within the digital controller. Please contact us if you are interested in receiving these parameters.

**Motor Controller** - The motor controller is located near the motor just below the top plate of the Machine. The motor controller is sealed in line with the electrical cord that runs to the brushless motor.

The motor controller on the Machine receives power and signals from the main control center located inside the external enclosure. These signals are used to operate the brushless motor at the commanded speed. The motor controller also sends feedback signals back up to the main control center.

Due to the high frequency of communication between the motor controller and brushless motor, the two components need to be located close to one another. This is the primary reason for having the motor controller located directly on the Machine.

All electronic connections on the Machine equipment should only be used for the inputs or outputs that they are labeled and designed for. If any of the leads going into the electronic controller are disconnected, be sure when re-connecting to place them in the proper position.

**Wiring** - All electric wiring includes corrosion-resistant, industrial cords with molded, weather and watertight connectors. The connectors are indexed to prevent improper wiring. A general electrical schematic can be found in the Maintenance and Field Adjustment section.

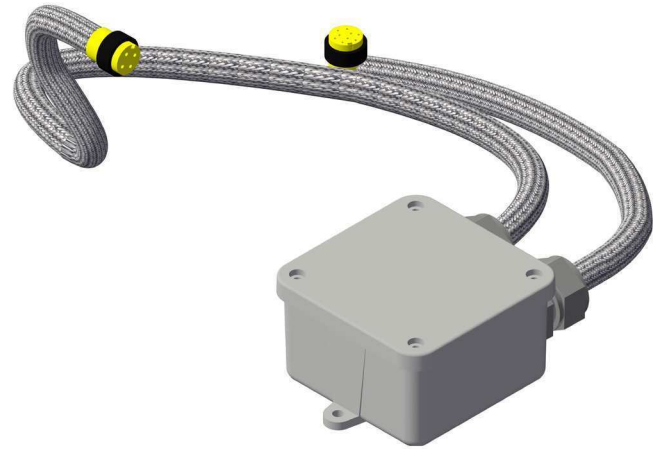

Motor Control Cord

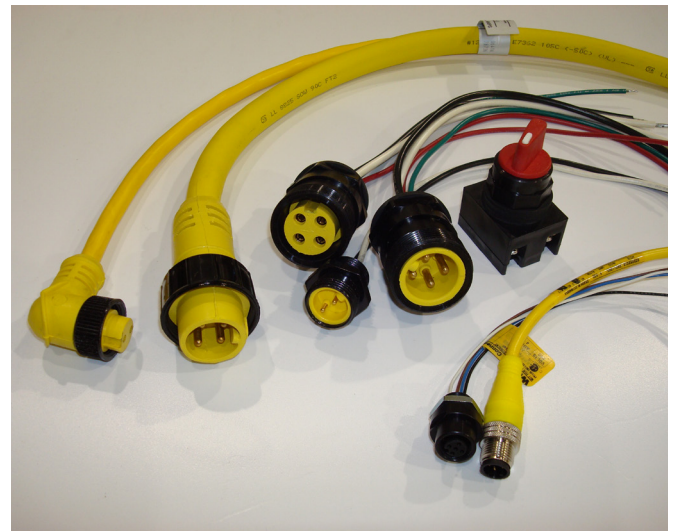

Durable Wiring And Connectors

## Features

## Features

### SB and GF Large Frame Mixers

#### Brushless Motor / Impeller

**Brushless Motor** - The brushless motor is located directly below the Top Deck. 4 bolts run down through the Top Deck and into the housing of the brushless motor fastening it onto the machine.

The brushless motor is built to be very durable. The housing is constructed of casted aluminum. The brushless motor runs very quietly and smoothly. It does not require any maintenance. A drive shaft extends through the bottom center of the housing.

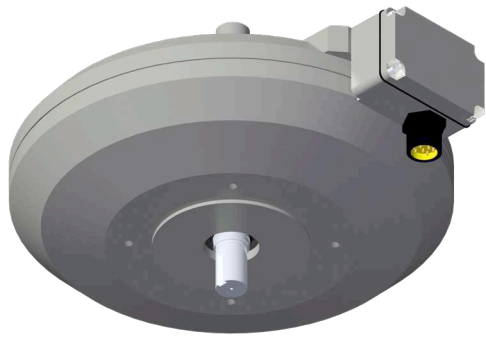

Brushless Motor



**CAUTION: THE BRUSHLESS MOTOR WEIGHS APPROXIMATELY 80 LBS (36KG). DO NOT REMOVE WITHOUT DISCUSSING THE PROCEDURES AND EQUIPMENT NECESSARY WITH A SERVICE TEAM MEMBER.**

**Shaft Coupling** - The shaft coupling connects the brushless motor drive shaft to the impeller shaft. The shaft coupling is located directly below the brushless motor and is made up of 3 main components. These components are called the upper coupling, lower coupling, and coupling sleeve. The shaft coupling is designed to allow quick disconnect for removal of the impeller assembly. Disconnecting the impeller shaft from the brushless motor shaft is simply accomplished by pulling out a pin and requires no tools. The upper coupling remains attached to the brushless motor while the lower coupling and coupling sleeve remain on the impeller shaft.

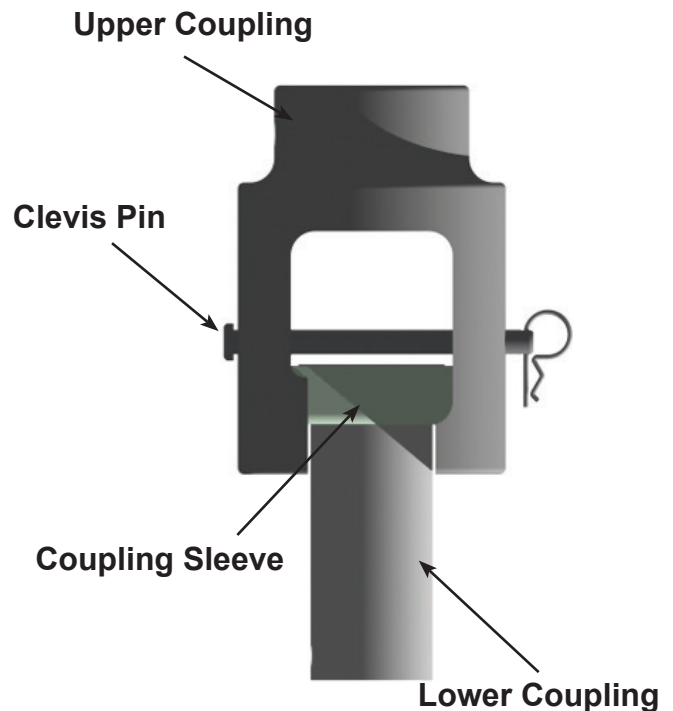



## Features

## Features

### SB and GF Large Frame Mixers

**Impeller Assembly** - The impeller assembly is made up of the stainless steel impeller shaft, stainless steel flag indicator, freeze sleeve, stainless steel impeller blades, and plastic impeller bushing. The impeller assembly is easily removed by pulling a pin on the shaft coupling.



**CAUTION: KEEP BODY APPENDAGES OR LOOSE CLOTHING AWAY FROM THE IMPELLER ASSEMBLY WHILE THE MACHINE IS OPERATING! IF MAINTENANCE IS REQUIRED, BE SURE TO TURN THE MACHINE OFF FIRST!**

The flag indicator is fixed to the shaft and used as a visual indicator of the impeller shaft's rotational speed.

An food grade oil-filled, Teflon freeze sleeve secured with o-rings surrounds the impeller shaft. The freeze sleeve is free to rotate on the shaft. If the water should freeze around the machine, the freeze sleeve will stand still, frozen in by the ice, but inside the plastic sleeve, the impeller shaft will be turning.

The impeller blades are welded to a hub that is securely fastened to the impeller shaft. The impeller is designed to gently pump water from below and can handle up to 4-inch (10cm) spherical solids.

The impeller bushing is a smooth collar that the impeller shaft tip fits into. The impeller bushing aligns and centers the impeller shaft within the machine.



**Turn Machine Off Before Performing Maintenance**  
**Impeller Assembly**

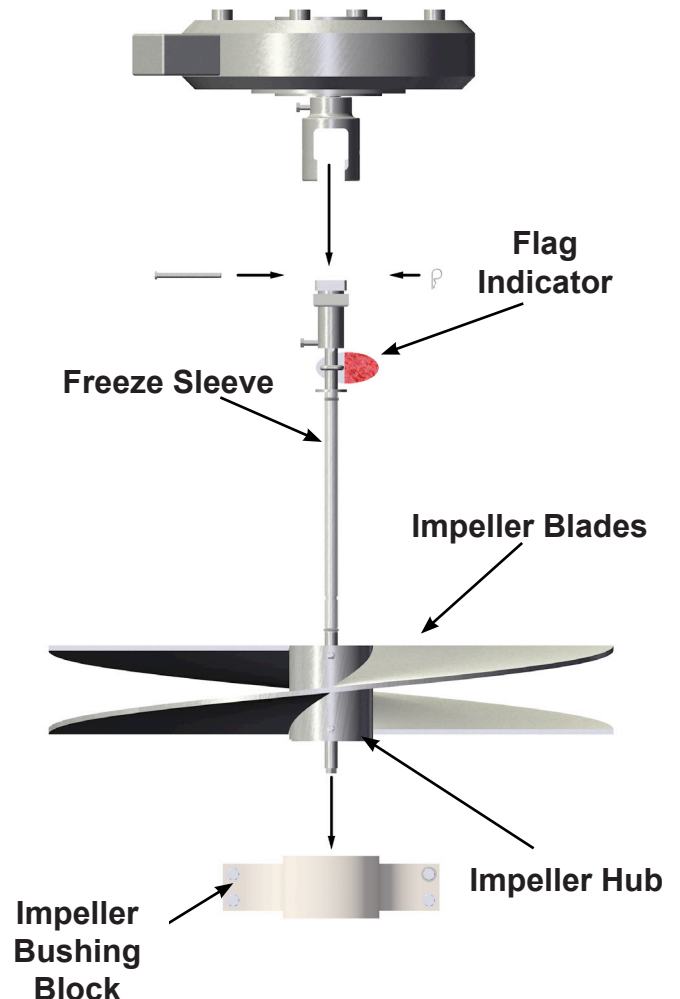

## Features

## Features

### SB and GF Large Frame Mixers

#### Distributor Dish

The distributor dish, structural members, structural fasteners, and mounting brackets are constructed of stainless steel.

**Distributor Dish** - Near-laminar flow is achieved by the Machine due to its uniquely designed distributor dish. The impeller rotates while sitting within the lower half of the distributor dish. There are also small water passages located below the dish to strengthen the induced flow effect (water movement occurring between the lower water layer entering the machine and the upper water layer leaving the dish).

The top lip of the distributor dish is set from 3/4 inch to 2.5 inches (2 cm to 6.4 cm) (**Please refer to the table below for exact settings**) below the surface of the water to achieve best flow results. The distributor dish depth is set by rotating the turnbuckles located on the float arms.

**MODEL MAY VARY**

Distributor Dish

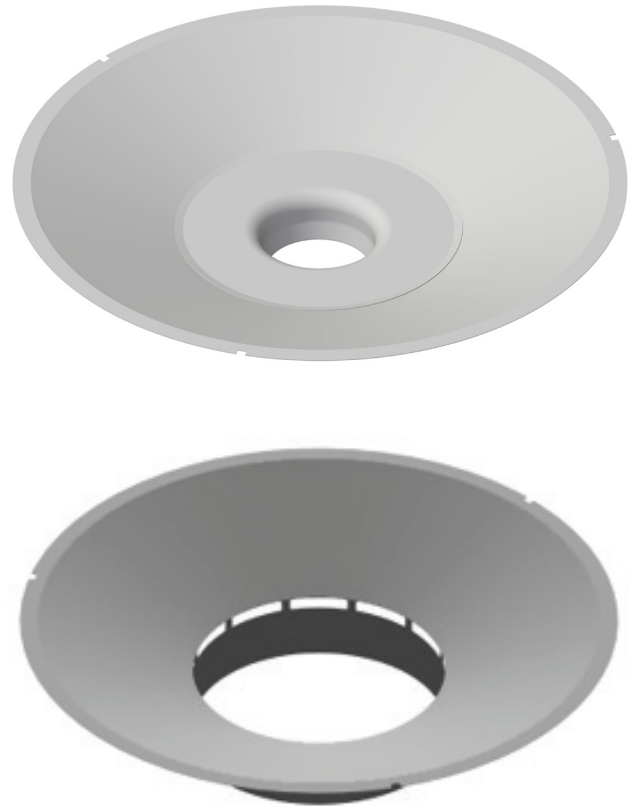

Machine Model	Water Level
2500	3/4 in to 1 in (2 cm to 2.5 cm)
5000	1 in to 1 1/2 in (2.5 cm to 3.8 cm)
7500	2 in to 2 1/2 in (5.1 cm to 6.4 cm)
10000	2 in to 2 1/2 in (5.1 cm to 6.4 cm)

## Features

## Features

### SB and GF Large Frame Mixers

**Hose / Strainer** - The hose is directly below the distributor dish and the strainer is located at the end of the hose. The strainer contains a buoyant float ball inside that allows the strainer to draw water from approximately 1.5 ft to 2 ft (0.45m to 0.6m) above solid bottom. The hose is designed to make a "J" shaped bend at the bottom so that the strainer does not draw sediment up from the bottom. The strainer has a chain connected to it and can be chained up at more shallow depths if necessary. The chain also is used for pulling up the strainer to check it for plugging.

#### Hose and Strainer Configuration - MODEL MAY VARY



**SB2500**



**SB5000**



**SB7500**

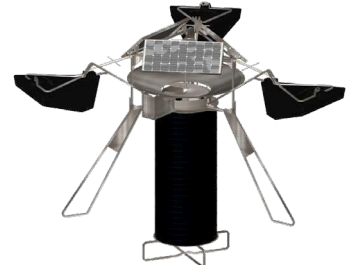

**SB10000**



**GF2500**



**GF5000**



**GF7500**



**GF10000**

## Features

## Features

### SB and GF Large Frame Mixers

#### Float Arms / Floats

The Machine contains 3 float arms and 3 floats. The float arms allow vertical positioning of the machine and the floats provide buoyancy.

**Float Arms** - The float arms are constructed of stainless steel components. They connect the floats to the central machine structure. Each float arm has a sturdy turnbuckle. The turnbuckles can easily be rotated to adjust the vertical height of the distributor dish. Lengthening the turnbuckle (rotating clockwise) will raise the lip of the distributor dish, whereas shortening the turnbuckle (rotating counter-clockwise) will cause the lip of the distributor dish to lower.

The turnbuckle and float arm structure components are constructed with robust stainless steel materials allowing the Machine to operate in severe environments without being damaged. The turnbuckle is self locking. Simply rotate the handle to expand or collapse the turnbuckle for dish depth adjustment.

It is important to check the distributor dish depth routinely. The Machine naturally drops into the water over time due to biomass buildup and trapped air escaping from the hose. If the distributor dish lip is too high, the water coming off the lip may become turbulent and the flow rate of the machine may be reduced.

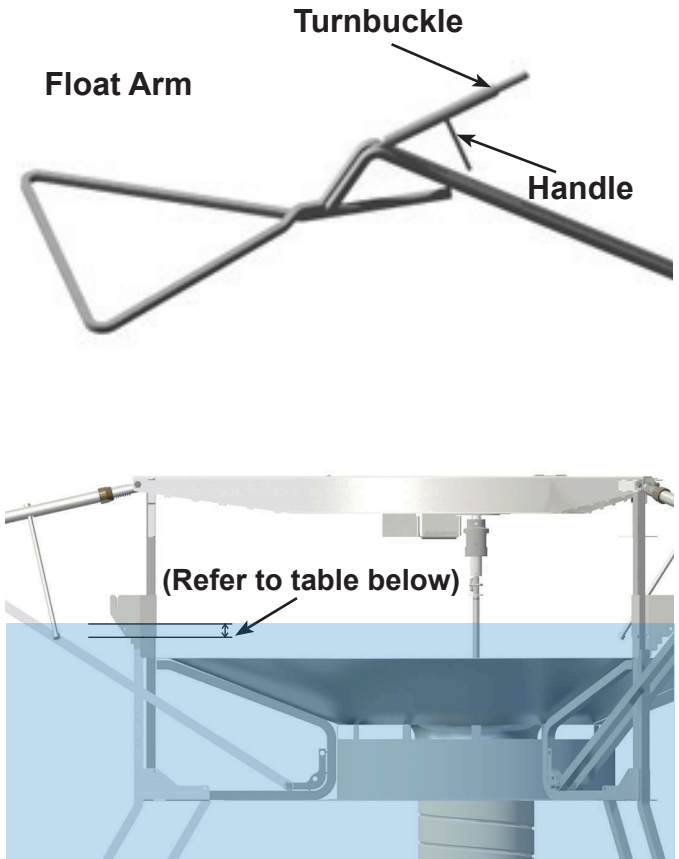

Distance Between Distributor Dish And Water Level

#### WATER LEVEL NOTCH SETTING FOR:

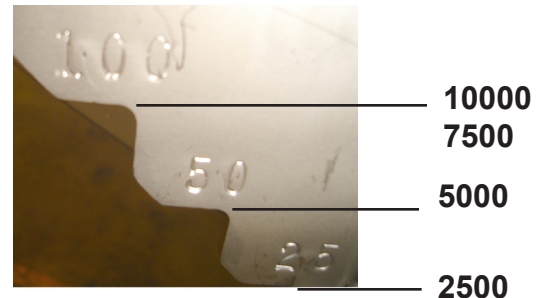

Dish Depths For Different Models

Machine Model	Water Level
2500	3/4 in to 1 in (2 cm to 2.5 cm)
5000	1 in to 1 1/2 in (2.5 cm to 3.8 cm)
7500	2 in to 2 1/2 in (5.1 cm to 6.4 cm)
10000	2 in to 2 1/2 in (5.1 cm to 6.4 cm)



## Features

## Features

### SB and GF Large Frame Mixers

If the distributor dish lip is too low, the water coming off the lip will flow just underneath the surface of the pond and the surface will not be renewed.

Each float arm is connected to the central machine structure with 1 bolt and 1 pin. Each float is connected to the float arm by 2 pins. The turnbuckle can be removed from the float arm by pulling a pin, but should only be done when the unit is resting on the shore.

If re-attaching the turnbuckle to the float arm, be sure that each threaded end of the turnbuckle together are screwed all the way in or all the way out before re-attaching. If threaded ends are not equally expanded or collapsed before fixing the ends, the turnbuckle will have limited adjustment.

**Floats** - The Machine has 3 floats, made from high density Polyethylene. The floats are filled with a Polystyrene closed-cell foam for long term buoyancy. The floats have a uniquely designed shape to:

- Minimize the interference with the water flow on the surface coming off the distributor dish.
- Have a low profile above the water for minimizing wind resistance and offering less exposure to vandalism.
- Avoid being crushed by ice pressure.
- Provide extra buoyancy when needed without going much deeper into the water.

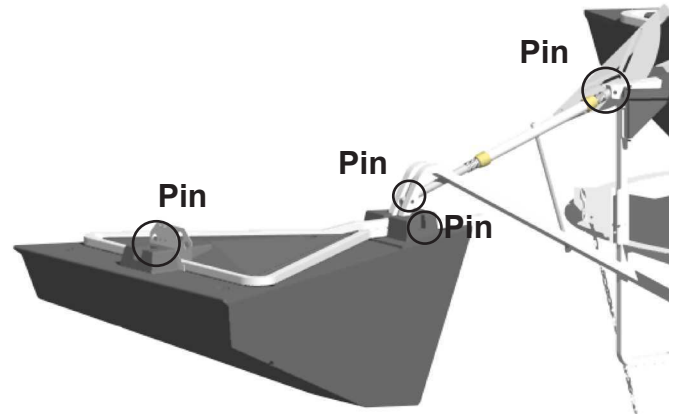

Float Arm Connection Points



**CAUTION: DO NOT REMOVE ANY FLOAT ASSEMBLY PINS OR BOLTS WHILE THE MACHINE IS FLOATING IN THE WATER! THE MACHINE MUST BE RESTING ON THE GROUND OR SAFELY SUPPORTED TO RELIEVE THE FORCES ON THE FLOAT ASSEMBLY STRUCTURES PRIOR TO DISASSEMBLY! FAILURE TO FOLLOW THIS WARNING COULD LEAD TO SINKING THE MACHINE OR SERIOUS INJURY!**

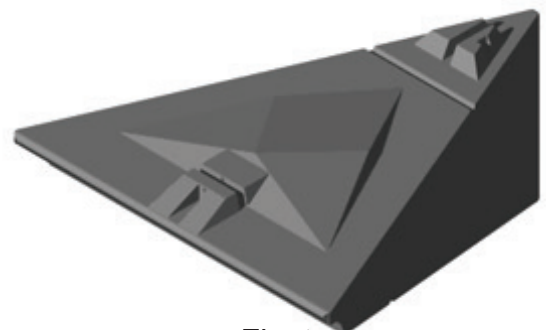

Float

## Features

# Features

## GF Large Frame Mixers Anchoring Systems

### Anchoring Systems

The GridBee uses a tethering system to secure the machine into position. The tethering system uses cable that spans across the pond or reservoir connecting to tethering anchors on the shoreline.

**Tethering System** - The tethering system consists of 2 duckbill anchors set into the shoreline across from one another. A stainless steel cable is strung across the pond or reservoir and tied to both tether anchors. The GridBee has 2 short chains running from two of the float arms through the float plates on the machine out to the cable line running across the pond or reservoir.

Following severe weather conditions (greater than 80-mph (129 km/hr) wind, higher than 4-ft (1.2m) waves, or ice thaw), it is possible for the duckbill anchors to pull partly or completely out of the ground, or the tether cable span across the pond to break loose from the duckbill anchors. If this should happen, the pond or reservoir operator will need to re-locate the machine to its original position.

**Movement of machine** - For a GridBee anchored by a tether system, the machine will have limited movement, however slack will be left to allow for water fluctuation. The tether line slack will be field determined based on tether line span and expected water fluctuation. The GridBee will not rotate when it is anchored using the tether system.

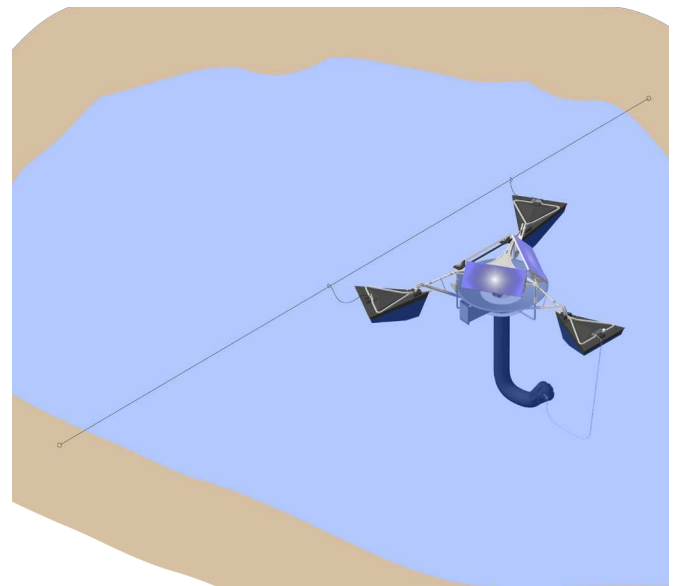

Tethering System

# Tethering Deployment

Duckbill Anchors

## Duckbill Anchoring Deployment

for Tethered SolarBee / GridBee Machines

**\*Verify that One-Call has been called and that buried lines have been marked.\***

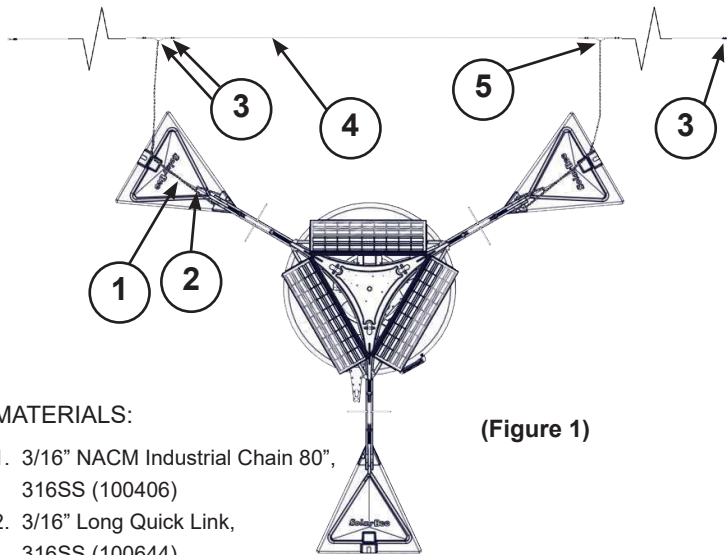

(Figure 1)

**MATERIALS:**

1. 3/16" NACM Industrial Chain 80", 316SS (100406)
2. 3/16" Long Quick Link, 316SS (100644)
3. Cable Clamp, 3/16" (12010412)
4. 3/16" cable, 316SS (10014018)
5. 3/16" cable loop, 316SS

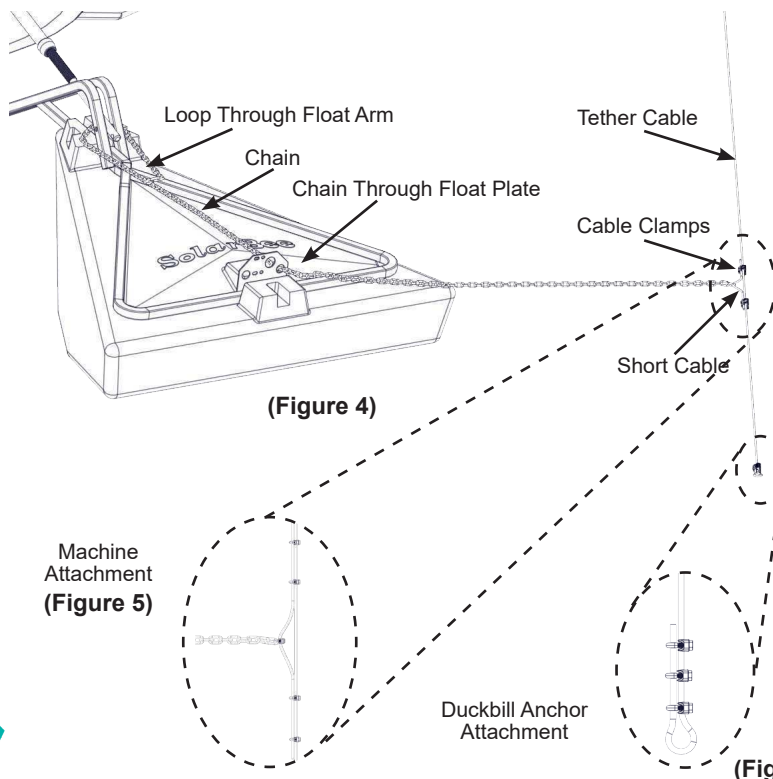

(Figure 4)

Machine Attachment (Figure 5)

Duckbill Anchor Attachment (Figure 6)

(Figure 6)

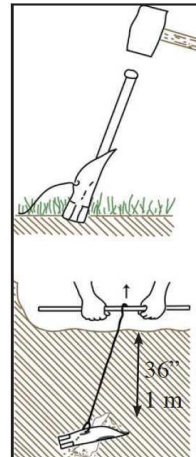

(Figure 2)

Rated for 3000 lb (13.3 kN) load.  
 Set at a depth of 3 ft (1m).  
 1/4" (6.35mm) SS Cable, 42" (1m) L  
 Aluminum Alloy 356 Duckbill  
 2 Duckbill anchors per Machine

**TOOLS REQUIRED:**

- (1) Sledge Hammer
- (1) Ø 5/8" or Ø 7/8" Steel Driving Rod
- (1) Pliers
- (2) 10 mm wrench and/or socket

**STEP 1:** Set two duckbill anchors across the pond from one another so that the center of a straight line between the two anchors is the approximate location that the SolarBee/GridBee will be placed. (Figure 1)

**STEP 2:** Drive in the duckbill anchors into the ground at desired location using a 5/8" or 7/8" rod. (Figure 2)

**STEP 3:** Tie off the tether cable to the eye loop of the duckbill anchor. Use 10 mm wrench to tighten both nuts on each cable clamp. (Figure 3 & 6)

**STEP 4:** Secure one end of the tether cable across the pond and tie it off to the other anchor leaving some slack/droop in the line. (See Figures 1, 3 & 6) The slack is for water fluctuation. If the pond has a large range of fluctuation, more slack should be left.

**STEP 5:** Secure short chain to the SolarBee float arm and the other end to the tethering cable. (Figure 4 & 5) Tighten quick link on float arm side using pliers. Tighten cable clamp side using 10 mm wrench.

**STEP 6:** Repeat step 5 for the second short chain and float arm.

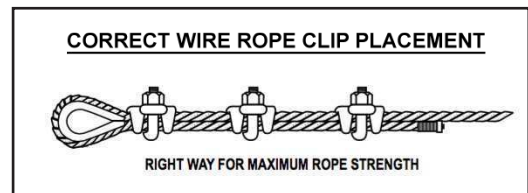

(Figure 3)

## Float Assembly

After familiarizing yourself with all the components and gathering the necessary tools, you are ready for setting up the Machine. Find a location where you have approximately 20 ft of working space near the reservoir that the Machine will be put in (The less distance you have to move the fully assembled machine, the better). Follow these steps to prepare the Machine before floating it in the water:

### NO TOOLS REQUIRED

**STEP 1:** Locate one float, one float arm, one float bracket, and 2 float pin sets. Observe that there are two slots on the top of the float which fit around the float arm. One slot runs left and right, the other runs front to back. If float pins are in the slots, remove them.

**STEP 2:** Orientate the float so that it will fit around the float arm when the float is raised into place.

**STEP 3:** Place the float plate into float slot 1 furthest from the core unit assembly aligning the holes of the float slot with the small holes on the float plate (see photo).

**STEP 4:** Once the float plate is in place on the float, raise the float up fitting it into the float arm. Use the float pins to secure the float to the float arm.

**STEP 5:** Place hairpins in each float pin to secure it and prevent the pin from coming out.

**STEP 6:** Repeat Steps 1 through 5 for the other two floats.

**NOTE:** The float plate may not be used on one of the three floats.

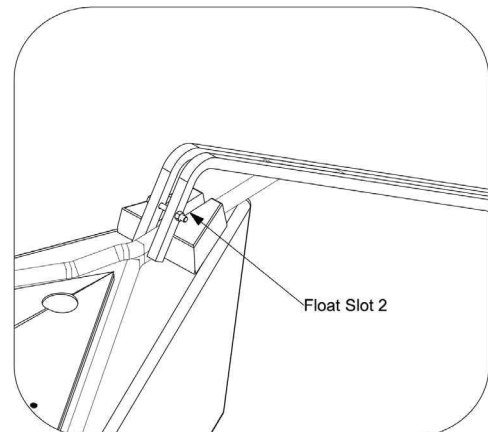
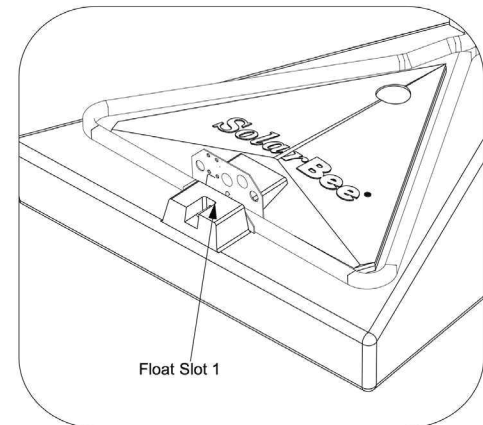
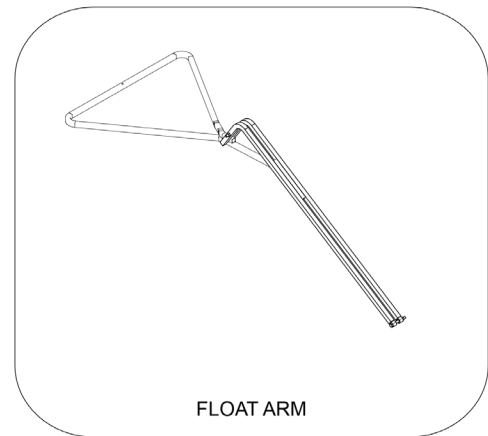

## Float Arm to Machine Attachment Assembly

**IMPORTANT:** IF WRONG CONNECTION HOLE IS USED, DISH DEPTH LEVEL MAY NOT BE OBTAINED DURING FINAL SETTINGS AND UNIT WOULD HAVE TO BE PULLED BACK OUT OF THE WATER, CORRECTED, AND RE-INSTALLED

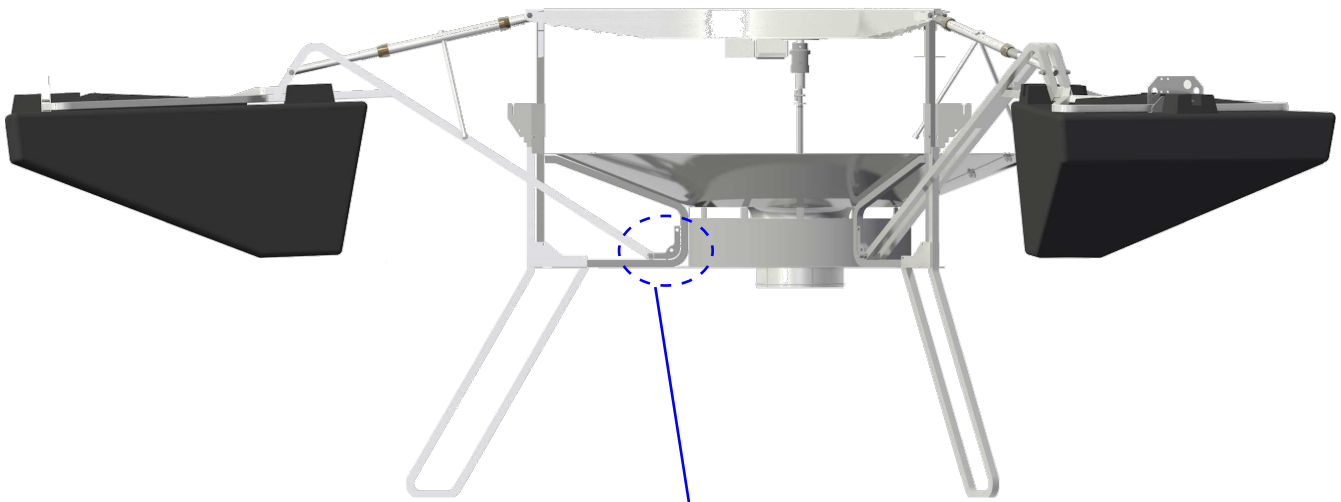

**SB10000 WITH 20FT OR MORE HOSE**  
**SB7500 WITH 20FT OR MORE HOSE**

**SB10000 WITH 15FT (4.5m) OR LESS HOSE**  
**SB 7500 20FT (4.5m) OR LESS HOSE**  
**ALL SB5000**  
**ALL SB2500**

**ALL POTABLE WATER UNITS**  
**ALL HIGH SALINITY (SALTWATER) APPLICATIONS**

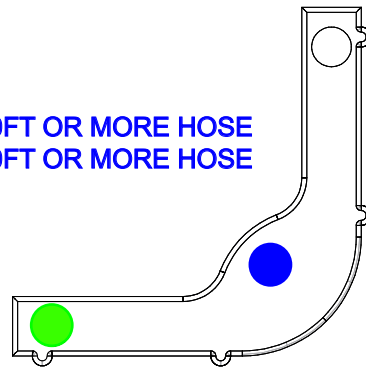



## Float Arm Assembly

### TOOLS REQUIRED:

(2) 19mm wrench  
19mm socket wrench (optional)

**STEP 1:** Reference the previous page to select which float arm connection hole is required for your machine.

**IMPORTANT:** Be sure to use the proper hole to avoid a prolonged installation.

**STEP 2:** Locate the 3 float arm assemblies. Have the M12 x 90mm long bolts and M12 nylok nuts easily accessible near the core unit assembly.

**STEP 3:** Take the float arm and slip the narrow end with Float Arm Stems around the core unit leg. Align the holes through the Float Arm Stems with the correct float arm connection hole determined from Step 1.

**STEP 4:** Once aligned slide the M12 X 90mm bolt through all holes. Tighten a M12 nylok nut onto the bolt until there is little play or space between the bolted components. Use a two 19mm wrenches to tighten nut.

**STEP 5:** Repeat steps 2 and 3 for the other 2 float arms.

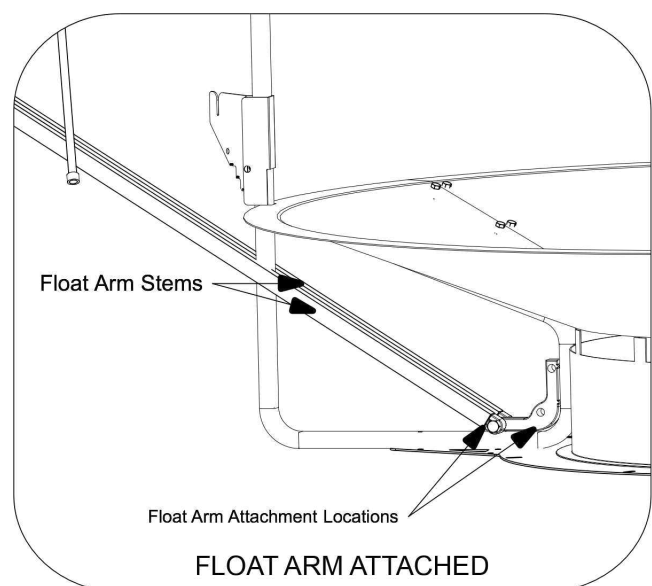
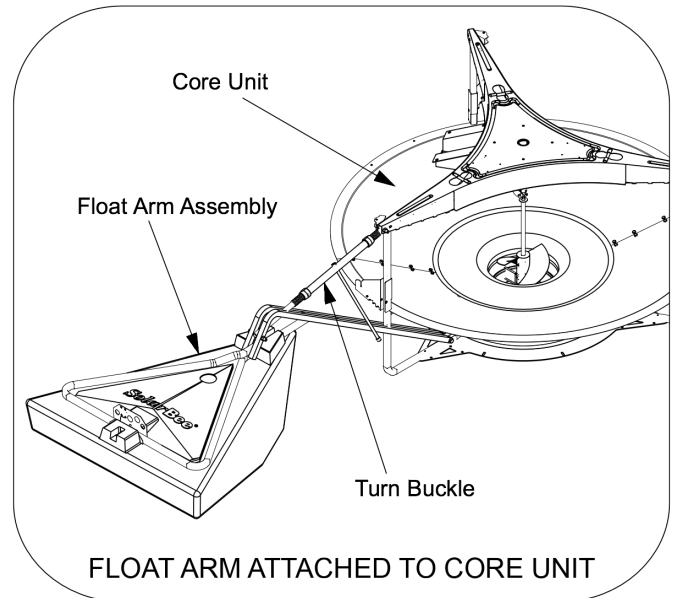

## Turnbuckle Assembly

### ••• IMPORTANT •••

Hold the center of the turnbuckle assembly and turn both ends all the way into the center. Skipping this step will cause decreased extension of turnbuckle and more time to install may be required.

#### NO TOOLS REQUIRED:

**STEP 1:** Locate the three turnbuckles, M12 90mm Bolts, M12 55mm Bolts, and Nylok Nuts.

**STEP 2:** Notice that the turnbuckle assembly has an end with a smooth shaft and the other end with threaded shaft.

**STEP 3:** Take the threaded shaft end of the turnbuckle assembly and slip it into the TriFrame of the core unit assembly. Align the holes and slide the M12 55mm Bolt into position and tighten the Nylok nut.

**STEP 4:** Once the upper part of the turnbuckle assembly is in place, take the opposite end of the turnbuckle and slide it into the float arm assembly as shown in picture.

**STEP 5:** Align the hole through the shaft with the float arm assembly holes and slide the M12 90mm Bolt and tighten the Nylok nut.

**STEP 6:** Repeat steps 2 through 5 for each turnbuckle assembly.

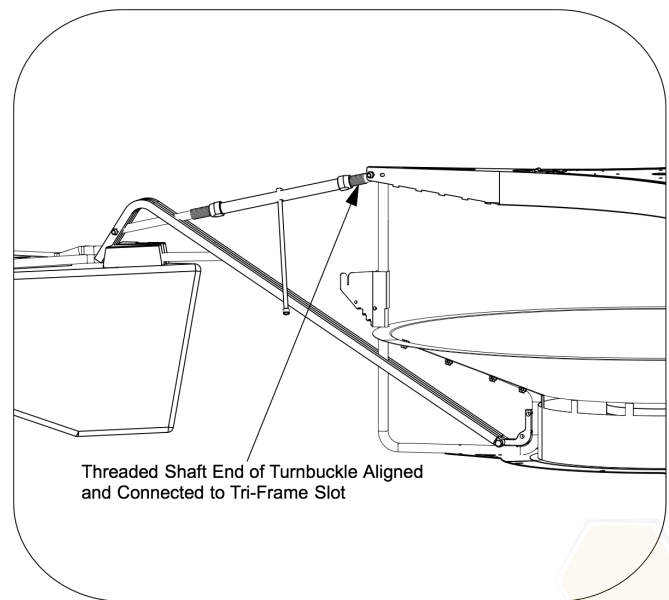
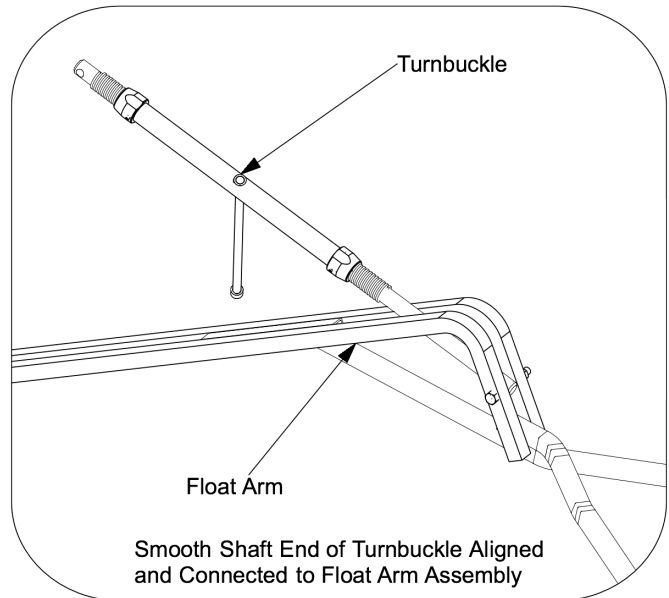

## Chain Bracket Assembly

### TOOLS REQUIRED:

- (2) 13mm wrench
- 13mm socket wrench (optional)

**STEP 1:** Locate the 3 chain brackets and the M8 X 45mm long bolts and M8 nylok nuts (3 sets needed).

**STEP 2:** Notice that along the perimeter of the dish on the core unit assembly, there are three locations where square tubing extends above the dish. Each of the 3 chain brackets will be attached to each of the three square tubing just above the dish.

**STEP 3:** Place one of the chain brackets over the square tubing with the wider side facing up and the opening facing outward.

**STEP 4:** Once the chain bracket is slid around the square tubing, insert the M8 x 45mm bolt through the outer holes in the chain bracket. Apply anti-seize to the threads of the bolt. Tighten the M8 nylok nut on the bolt to keep the chain bracket in place using two 13mm wrenches.

**STEP 5:** Repeat steps 3 and 4 for the other 2 chain brackets.



Applying Anti-Seize To The Bolts

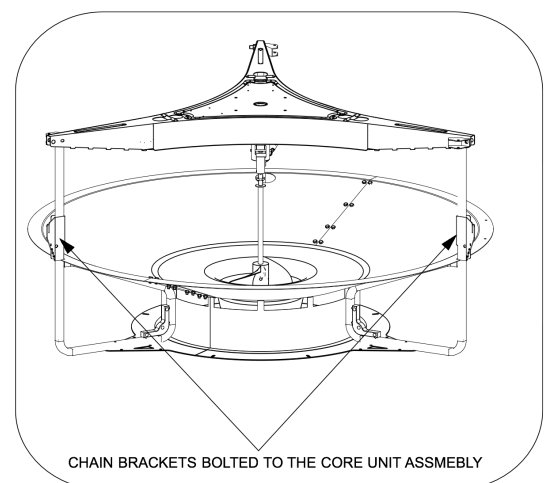
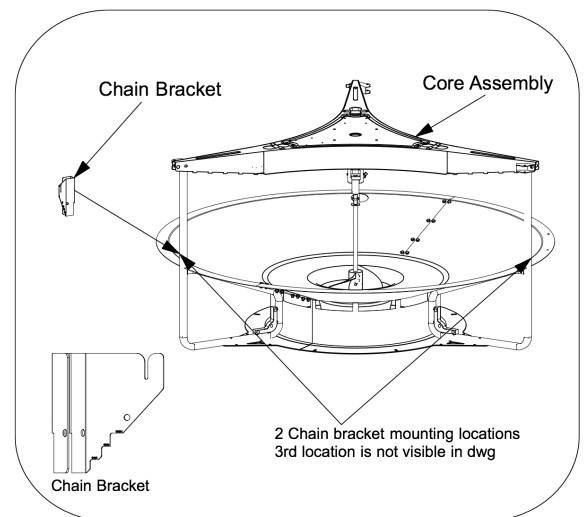
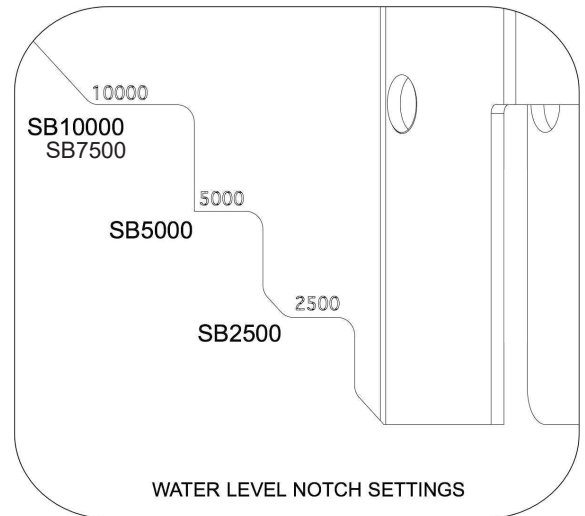



## Leg Extension Assembly (IF APPLICABLE)

### NO TOOLS REQUIRED:

**STEP 1:** Tilt or hoist the core unit assembly off the ground. Now the leg extensions can be attached.

**STEP 2:** Slide the leg extension around the three legs of the Machine core unit assembly and above the bottom flange ring.

**STEP 3:** Slide the leg extension up snug against the leg to allow two pins to be inserted through the holes of the leg extension.

**STEP 4:** Fasten the leg extension to the Core unit assembly using a set of two 5/16 inch x 2 inch (8mm x 51mm) clevis pins.

**STEP 5:** Secure both pins using two hair pins.

**STEP 6:** Repeat steps 2 through 5 for each leg extension.

**NOTE:** Once the leg extensions are attached and secure, the leg extensions act as a tri-pod in which the Machine can rest on.



Sliding Leg Extension Around Bottom Leg Of Machine Core Unit



Attaching Leg Extension With a Clevis Pin.

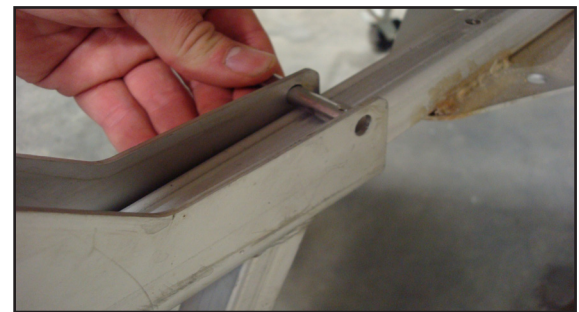

Securing Clevis Pins



Secured with Hair pins

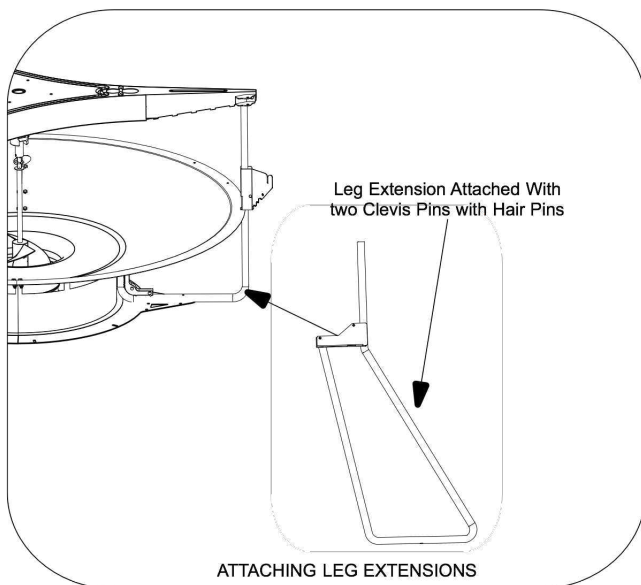

## Intake Marker Chain Assembly

### TOOLS REQUIRED:

Pliers

**STEP 1:** Locate the three marker chain sets. These will provide the means to lowering and raising the intake plate level.

**STEP 2:** The marker chain has numbered indicators represent the depth of the intake plate when that numbered indicator is at water level. For this reason, when attaching the marker chain, the numbers should start highest value at the top and the lowest value at the bottom. The numbers are indicated in feet.

**STEP 3:** Locate the very lastlink in the chain end having the highest numbered indicator. Use a quick link to attach the link to the small hole located on the chain bracket. Tighten the quick link using a pliers.

**STEP 4:** Find the last link on the end having the lowest numbered indicator. This link should attach to the welded link located directly below the chain bracket on the hose flange connected to the intake plate. Use a quick link to make this attachment. Tighten the quick link using a pliers.

**STEP 5:** Once marker chain is connected to the chain bracket and hose flange, pull the chain tight from the nose flange and slide it into the chain slot on the chain bracket.

**STEP 6:** Repeat steps 2 through 5 for each marker chain.

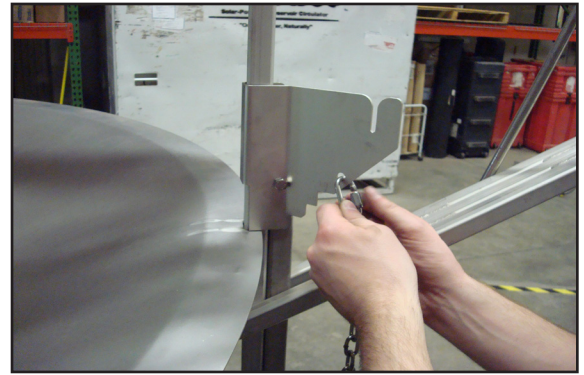

Quick Link connecting end of chain to small chain bracket hole.



Weld link on hose flange connecting opposite end of chain to hose flange.



Marker chain slipped into chain bracket slot.

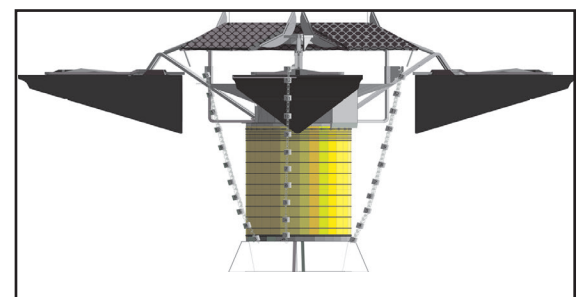

Machine equipped with 3 marker chains.

## Maintenance

# Maintenance and Field Adjustment

## SB / GF Series Large Frame Mixers

The performance of the Mixer has proven to increase tremendously when its operator understands the operation of the machine and knows how to carry out field adjustment procedures.

In most applications, it is strongly encouraged that the operator have a boat to perform routine checkups and field adjustment procedures on the Machine. A large, expensive boat isn't necessary. Our field teams use 12 ft (3.65m) Jon boats that work fine for almost all applications.

It is extremely important that safety comes first every time the Machine is inspected or having maintenance procedures performed. It is strongly encouraged that anyone working on or near the machine follow these rules:



⚠️ Wear a personal floatation device

⚠️ Stay focused and alert

⚠️ Turn the Machine off before working on it

⚠️ Stay clear of parts while they are moving

To turn the Machine motor off, turn the On / Off switch to the off position. To completely power down the digital controller, remove all power sources in the proper sequence.



**SAFETY FIRST**

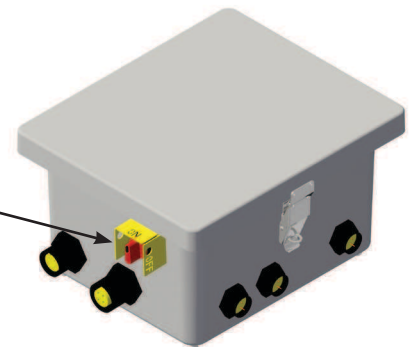
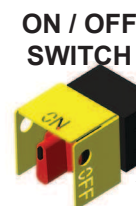

**DIGITAL  
CONTROLLER**



## Maintenance

# Large Frame Rigging Points

## SB/GF Series Large Frame Mixers

When deploying a Machine into the reservoir, it may need to be suspended. If suspending the Machine, it must be suspended from all three rigging points to ensure the support of the weight of the Machine and to keep the Machine balanced once suspended. A crane or hoist is often needed in order to suspend the Machine for deployment into the reservoir.

### TOOLS REQUIRED:

Crane or Hoist (if necessary)

Boat

**STEP 1:** Adjust all three turnbuckles to their full extension. This will raise the entire Machine to its maximum height and aid in towing.

**STEP 2:** Using a three point rigging system, connect to all three rigging points of the Machine. Hoist the Machine by the three rigging points and slowly lower into the reservoir.

**STEP 3:** Tie as much of the hose up as possible. This will reduce some drag when towing the Machine to its position in the reservoir.

**STEP 4:** Towing the Machine can be done one of two ways. The first way is to hook a chain, or towing line, around one of the float arms and pull the Machine with a boat. A second option, and in most cases is the best option, is to push the Machine using the front of the boat.

**IMPORTANT: DO NOT EXCEED 5 MPH (8KM/HR) WHEN TOWING OR PUSHING A MACHINE.**

**STEP 5:** Once in position, lower the hose into the water. If the hose and strainer are not completely submerged, push them both down until the air trapped inside is released. Once the air is released, the hose will lower down into place.

**MODEL MAY VARY**



Rigging Points



**CAUTION: DO NOT REMOVE ANY FLOAT ASSEMBLY PINS OR BOLTS WHILE THE MACHINE IS FLOATING IN THE WATER! THE MACHINE MUST BE RESTING ON THE GROUND OR SAFELY SUPPORTED TO RELIEVE THE FORCES ON THE FLOAT ASSEMBLY STRUCTURES PRIOR TO DISASSEMBLY! FAILURE TO FOLLOW THIS WARNING COULD LEAD TO SINKING THE MACHINE, OR CAUSE SERIOUS INJURY!**

# Maintenance

## Large Frame Dish Levels

### SB / GF Series Large Frame Mixers

#### Distribution Dish Level Setting

The machine distributor dish depth in the water is a key factor in maintaining the near-laminar flow of water coming off the machine.

The distribution dish level setting is measured from the top lip of the dish up to the water surface. For the Large Frame machine, set the depth level according to the following table:

Model	Depth - Inch	Depth - cm
2500	3/4 - 1	2.0 - 2.5
5000	1 - 1 1/2	2.5 - 3.8
7500	2.0 - 2 1/2	5.1 - 6.4
10000	2.0 - 2 1/2	5.1 - 6.4

#### Distribution Dish Level Adjustment

##### TOOLS RECOMMENDED:

Tape Measure

**STEP 1:** If machine is not on, turn the On/Off switch to the On position.

**STEP 2:** Observe if the dish level is too deep or not deep enough at the three locations where each float arm extends out from the machine. This can be done using a tape measure, by approximating the height of a nickel, or locating the notch on each chain bracket for machines having a hose. If using the notch on each chain bracket, the water level should be even with the appropriate notch (see picture).

**STEP 3:** Set the dish to the correct level in each of the three locations. To raise the dish level, rotate the turnbuckle around (clockwise) so that it is expanding. To lower the dish level, rotate the turnbuckle around (counter-clockwise) so that it is compressing.

**STEP 4:** Double check dish level at all three locations and fine tune as necessary.

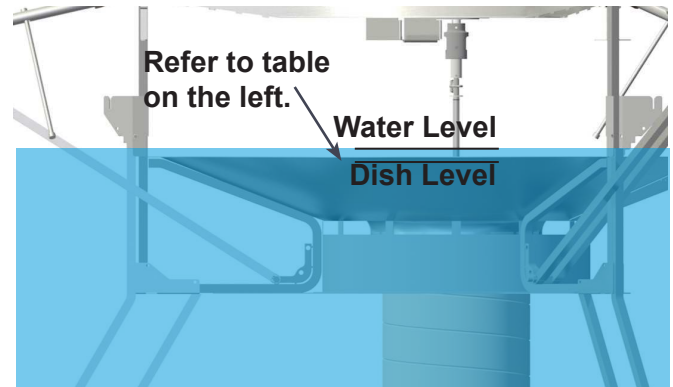

Distance Between Distributor Dish And Water Level

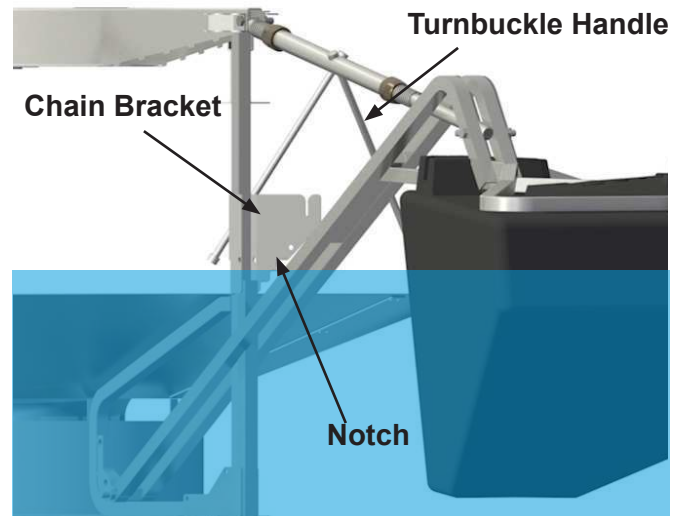

Water Level Even With Notch On Chain Bracket

#### WATER LEVEL NOTCH SETTING FOR:

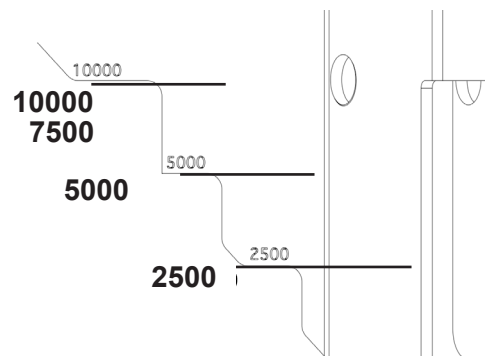

Dish Depths For Different Models of machines

# Maintenance

## RPM Check

### SB/GF Series

#### Impeller Rotational Speed Check

During clear skies and good sunlight weather conditions, the drive system of the unit should operate:

- 1) At a rotational speed between 55 and 85 revolutions per minute (rpm).
- 2) In a clockwise direction when looking down at the impeller.

#### Checking Rotational Speed

##### TOOLS RECOMMENDED:

Watch or Stopwatch

**STEP 1:** Locate the flag indicator on the impeller shaft.

**STEP 2:** Start the stopwatch or mark a starting point on the watch. Immediately begin counting each full revolution of the flag indicator (starting with "ZERO", "ONE", "TWO", etc) for a time of less than or equal to 1 minute and at least 20 seconds. This step is easier with two people, one counting revolutions and the other keeping track of the time expired.

**STEP 3:** Quit counting revolutions and immediately observe how much time has expired in seconds.

**STEP 4:** Use the following equation to calculate rotational speed in rpms:

$$\text{Revolutions Per Minute (RPM)} = \frac{(\# \text{ Revolutions Counted} \times 60)}{\# \text{ Seconds Expired}}$$

MODEL MAY VARY

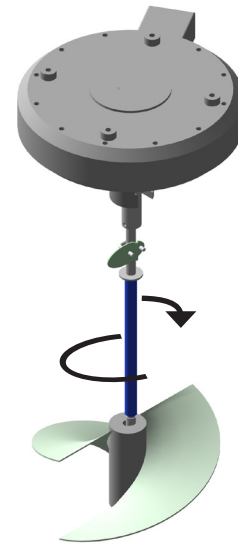

Clockwise Rotation When Looking Down

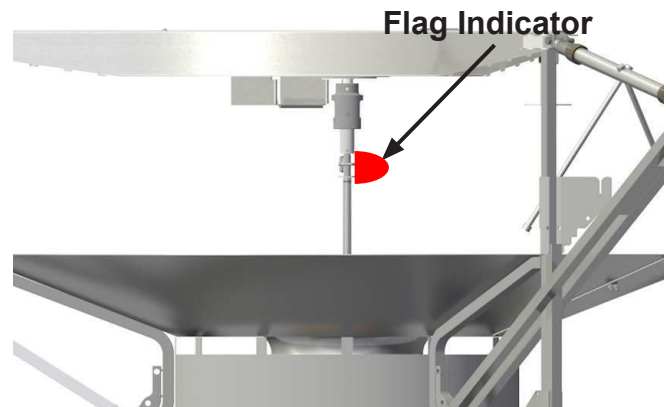

Flag Indicator Section of Impeller Shaft

Example: 30 Revolutions were counted in a time period of 30 seconds.

$$\text{RPM} = (30 \text{ revolutions} \times 60) / (30 \text{ seconds}) = 60$$

Impeller Rotational Speed = 60 RPMs

# Maintenance

## Impeller Cleaning

SB / GF Series Large Frame Mixers

In some applications, the autoreverse function will not completely eliminate floating debris or aquatic weeds from catching on the impeller blades and shaft. In these applications, impeller cleaning and impeller removal may be necessary.

### Impeller Cleaning

#### TOOLS RECOMMENDED:

- Elbow High Rubber Gloves
- Squeegee
- Garbage Bag



**STEP 1:** Turn Machine off by placing the On/Off switch into the OFF position.

**STEP 2:** Open PV module gate for easy access to the impeller. If necessary for better access, use the three turnbuckles to raise machine level.

**STEP 3:** Using gloves and squeegee, clean off debris or aquatic weeds that are wrapped around impeller blades and shaft. Place the debris into a garbage bag and remove from pond to prevent it from going through Machine again. **Follow all local laws and regulations when disposing of any materials collected.**

**STEP 4:** Observe if there is buildup below the impeller blades.

If below the impeller is clean, then close the PV module gate, lower dish into the water at proper setting using the turnbuckles, and screw in fuse switch to turn Machine back on.

If there is buildup below the impeller, then see directions for impeller removal on the next page.



Machine With Buildup On Impeller



**CAUTION**  
**Moving blade.**  
Rotating parts and shaft can cause injury.  
Keep hands clear while machine is operating.

**CAUTION: TURN MACHINE OFF BEFORE WORKING NEAR IMPELLER! WEAR PROTECTIVE GLOVES AND BE CAUTIOUS OF SHARP LEADING EDGES ON IMPELLER BLADES WHILE CLEANING! FAILURE TO FOLLOW THESE WARNINGS COULD LEAD TO INJURY!**



Impeller Removal For Buildup Below Impeller



# Maintenance

## Impeller Assembly Removal

SB / GF Series Large Frame Mixers

### Turn Machine Off Before Performing Maintenance

In the case that there is buildup below the impeller that cannot be reached, the rotating assembly can easily be removed.

#### TOOLS RECOMMENDED:

Elbow High Rubber Gloves  
Garbage Bag



**STEP 1:** With Machine off and PV module gate open, locate the clevis pin going through the upper shaft coupling. Remove the hair pin and pull clevis pin out.

**STEP 2:** Grab the impeller shaft below the flag indicator, lift up and then outward until lower coupling and shaft are disconnected from upper coupling and brushless motor.

**STEP 3:** Observe and clean any debris located on the bottom of the impeller.

**STEP 4:** Observe and clean any debris located down in the dish where the impeller rests. Place the debris into a garbage bag and remove from pond to prevent it from going through Machine again. Follow all local laws and regulations when disposing of any materials collected.

**STEP 5:** Once clean, place impeller assembly back in place (Slide lower coupling into upper coupling and allow to drop down into place). Be sure bottom of impeller shaft fits into the bushing in the dish and that the coupling sleeve is in place inside the shaft coupling assembly.

**STEP 6:** Place clevis pin back through upper shaft coupling and secure with hair pin.

**STEP 7:** Close PV module gate and turn Machine back on.

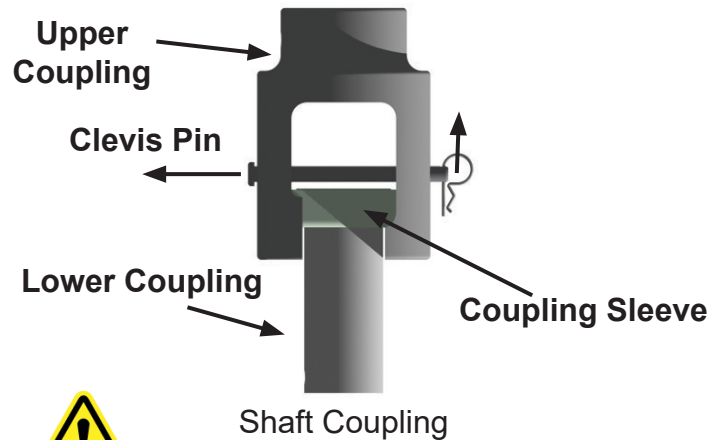

**CAUTION: TURN MACHINE OFF BEFORE WORKING NEAR IMPELLER! WEAR PROTECTIVE GLOVES AND BE CAUTIOUS OF SHARP LEADING EDGES ON IMPELLER BLADES WHILE CLEANING! FAILURE TO FOLLOW THESE WARNINGS COULD LEAD TO INJURY!**

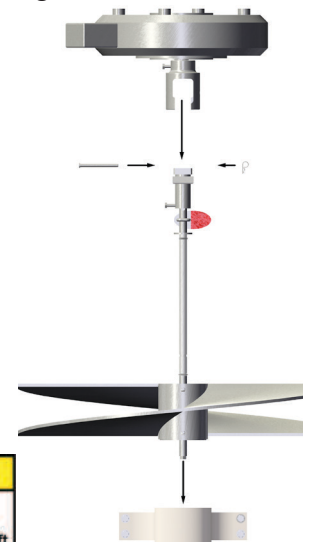

Impeller Assembly Removal Motion

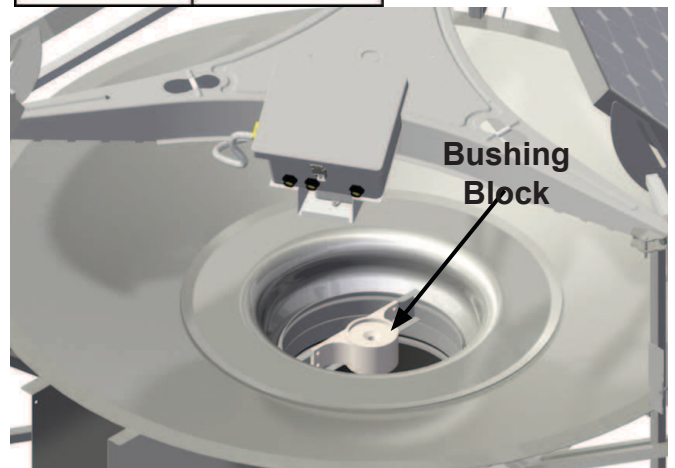

Impeller Assembly Removed



# Electrical

## Electrical Overview

GF Series Large Frame Mixers

**GRID POWER ONLY  
120VAC 60HZ @ 2.0 AMPS**







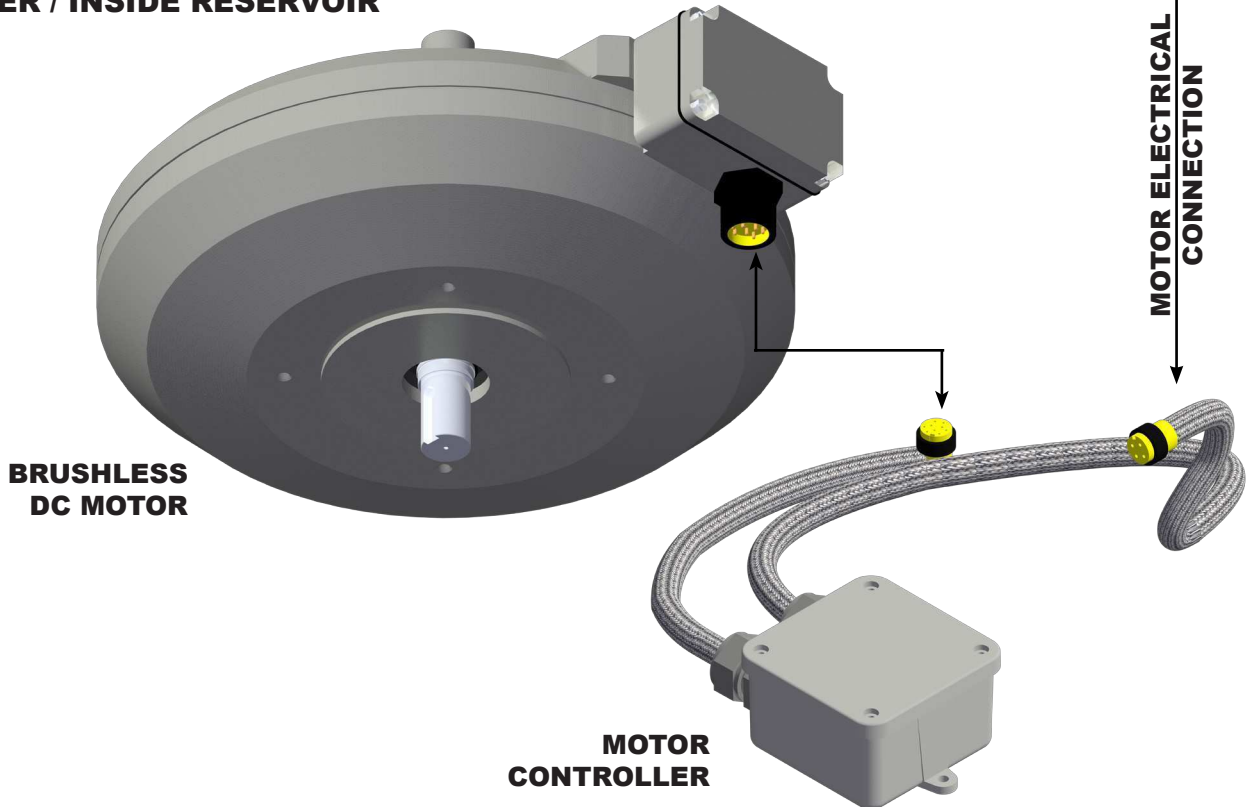



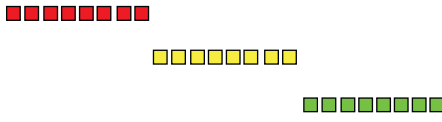

**ON SHORE / OUTSIDE RESERVOIR**

**ON MIXER / INSIDE RESERVOIR**

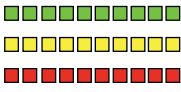

# SolarBee/GridBee SD Card

## Update Instructions

Insert the SD card into the slot. The solid blue light beside the slot will come on.	 SD CARD INSERTED
Once the correct files have been found, the green light will begin to flash rapidly.	 FILE SEARCH AND DOWNLOAD
When it is time to remove the card, the green and yellow lights will flash rapidly and be alternating. <b>Remove the SD card from the slot.</b>	 DOWNLOAD COMPLETE REMOVE SD CARD
When the card is removed, the red light will flash rapidly. This is the beginning of the self programming with instructions received from the SD card. After the red light is finished, the yellow light will flash rapidly, followed by the green light.	   INITIALIZING PROGRAM
Upon completion the brainboard will restart and perform a system check. <b>Following a successful update</b> the red light blinking once followed by one yellow blink and one green. If you miss this or are unsure, you can repeat the previous steps	   SD CARD UPDATE SUCCESSFUL
If the update was not successful, the red, yellow, and green lights will blink together 10 times. The machine will revert to the default parameters. Insert the card to attempt the update again. If it still fails, contact Customer Service.	   UNSUCCESSFUL SD CARD UPDATE

*Please refer to the provided owners manual for normal operation led blink codes.*

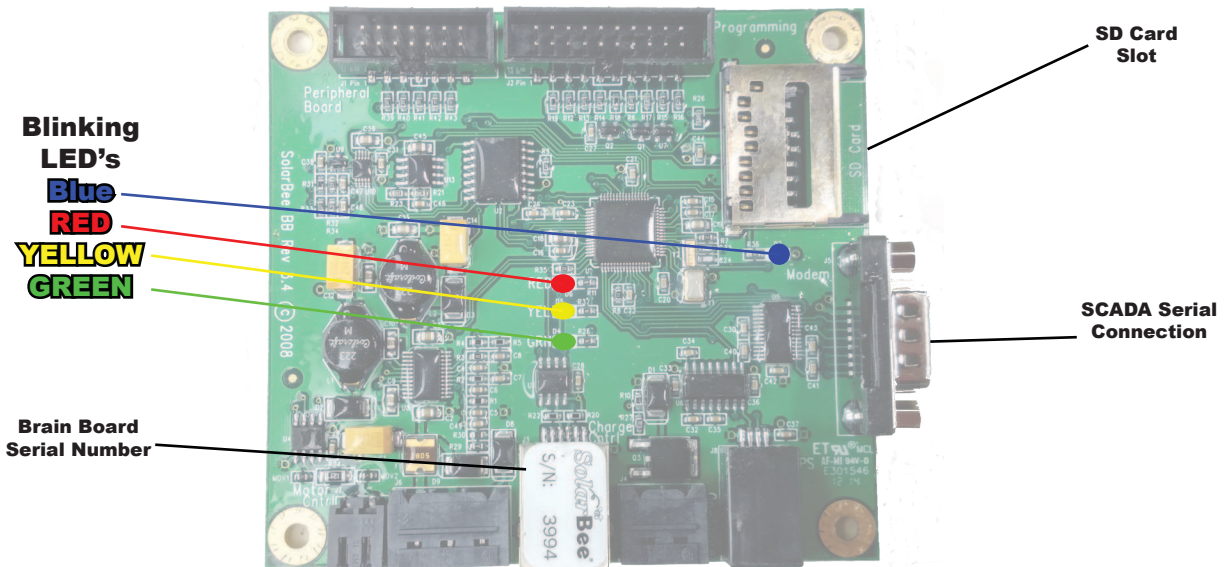

Figure 1: Brainboard

# Troubleshooting

# Troubleshooting

GF Series

## Electrical Hazard

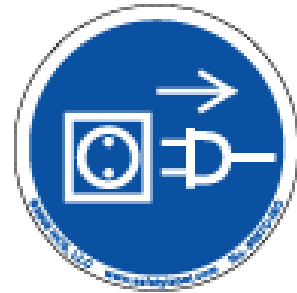

**WARNING: LIVE 110VAC POWER IS PRESENT INSIDE THE ELECTRICAL BOX FOR THE MODEL GF1250PWc. DISCONNECT GRID SOURCE POWER BEFORE SERVICING THESE COMPONENTS. ONLY CONNECT GRID POWER (AC) SOURCE INTO THE PROPER LOCATION. FAILURE TO FOLLOW THIS WARNING CAN RESULT IN SERIOUS INJURY OR DEATH FROM ELECTROCUTION. TURN GRID (AC) POWER OFF BEFORE ENTERING ENCLOSURE.**

---

***IXOM WATERCARE, INC. STRONGLY RECOMMENDS THAT AN ELECTRICIAN INSTALL A BREAKER SWITCH OR OTHER TYPE OF SWITCH THAT WOULD DISCONNECT AC POWER GOING INTO THE ELECTRONIC CONTROL BOX. A SWITCH IS NECESSARY TO KILL ALL AC GRID POWER INTO THE ELECTRONIC CONTROL BOX IF THERE BECOMES A NEED TO PERFORM ANY TYPE OF SERVICE INSIDE THE ELECTRONIC CONTROL BOX.***

# Troubleshooting

## Troubleshooting

### GF Series

If you find that the GridBee has quit operating, the following checks can be performed by a qualified person such as an electrician:

#### Checks -

- 1) Verify that there is power available to the control box and the On/Off switch is in the On Position.
- 2) Confirm that the motor circuit fuse (4 Amps) is not blown.
- 3) Follow each cord from the external electronic controller to its originating component and be sure it is not damaged or compromised.

#### OPTIONAL Visual Electronic Controller Check

- The GridBee contains an LED (Light Emitting Diode) blink sequence that indicates the machine operation status. The blinking LEDs are found on the Brain-board located inside the control box. Normal GF10000PW operation will include a 4X Red Blink Code.

#### DC Voltage Check -

If a DC voltmeter is available, the motor circuit voltage can be measured off terminal blocks 1 and 2. The proper motor voltage should be approximately 45vDC

Brain Board voltage should be approximately 12vDC and can be measure as shown to the right.

**Ixom Watercare, Inc. is committed to serving our customers. Feel free to contact a Ixom Watercare, Inc. Customer Service Representative if you experience any problems with your GridBee. At Ixom Watercare, Inc., we will get you technical support, parts, or a service visit to make sure that your GridBee is back online in short time. (866) 437-8076 or customerservice@ixom.com**



12 VDC+ 12 VDC-

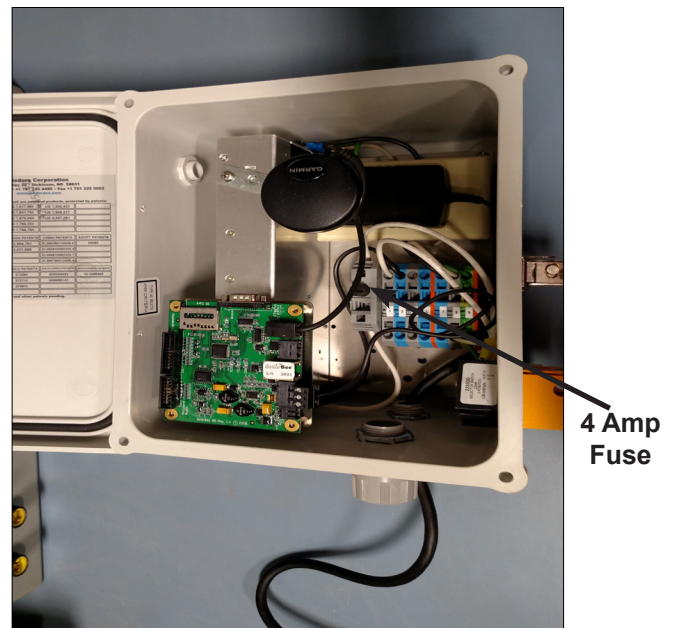

4 Amp Fuse

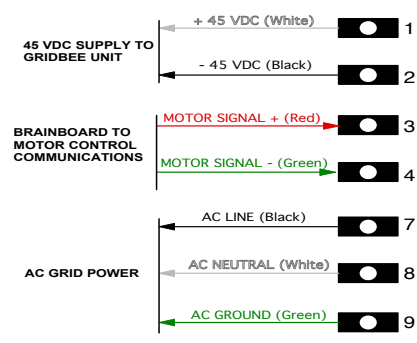





# Parts Diagram

## GF10000 Parts Diagram

NO.	PART#	DESCRIPTION
01	PN: 22281100	Impeller Assembly
02	PN: 18010002	Distributor Dish
03	PN: 18260225	Float Arm Assembly
04	PN: 24010100	Float
05	PN: 18265000	Turnbuckle Assembly
06	PN: 100161	Control Box
07	PN: 14013022	Motor Control Cord
08	PN: 20014500	14" Brushless Motor
09	PN: 26023610	36" x 10' Hose
10	PN: 26128000	Intake Plate

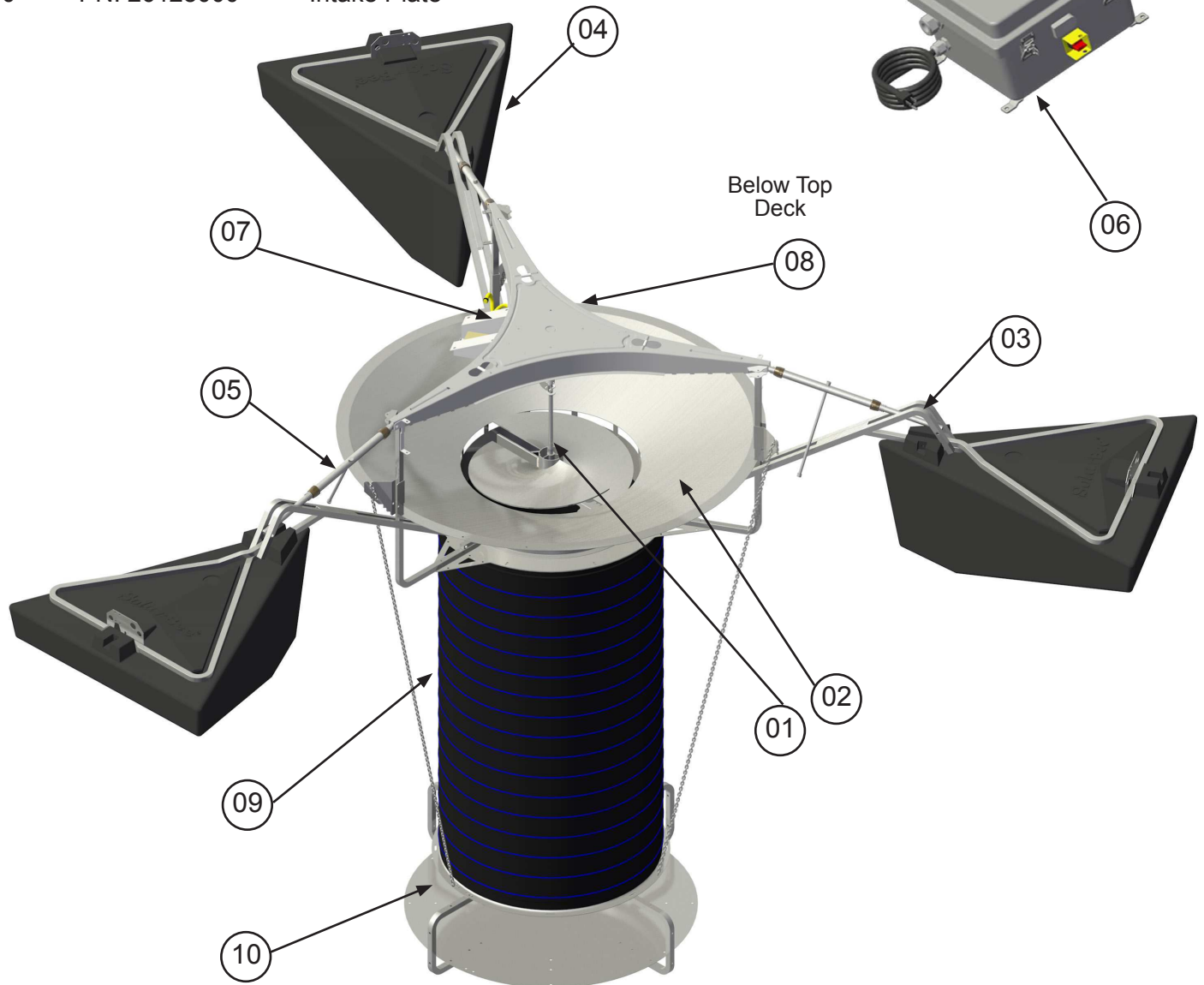

# Dimension Drawing

## GF10000

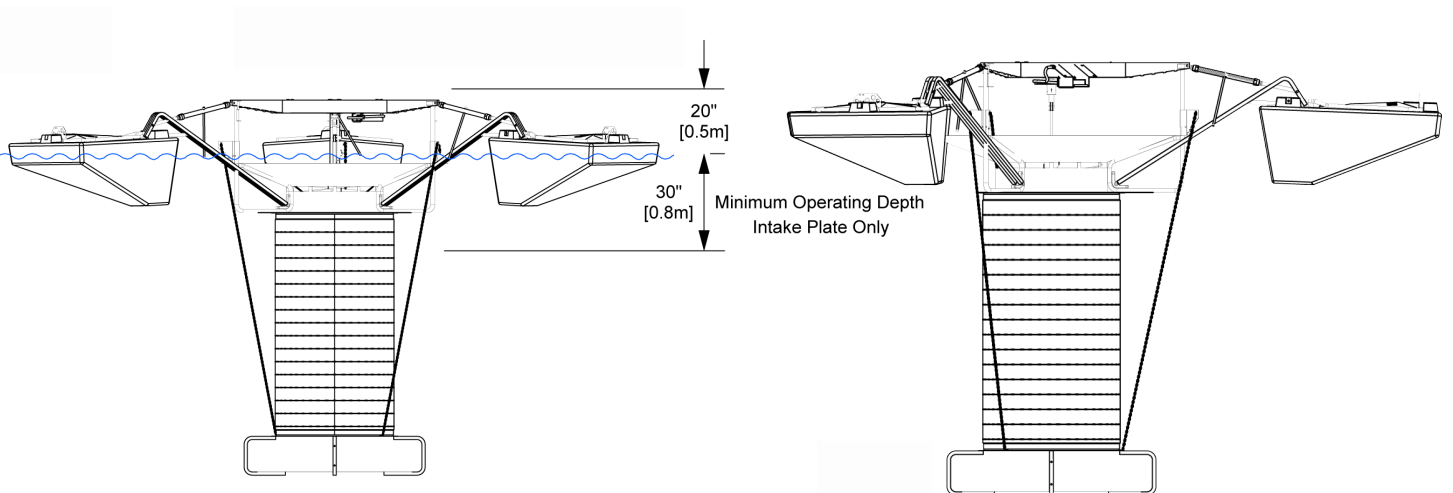
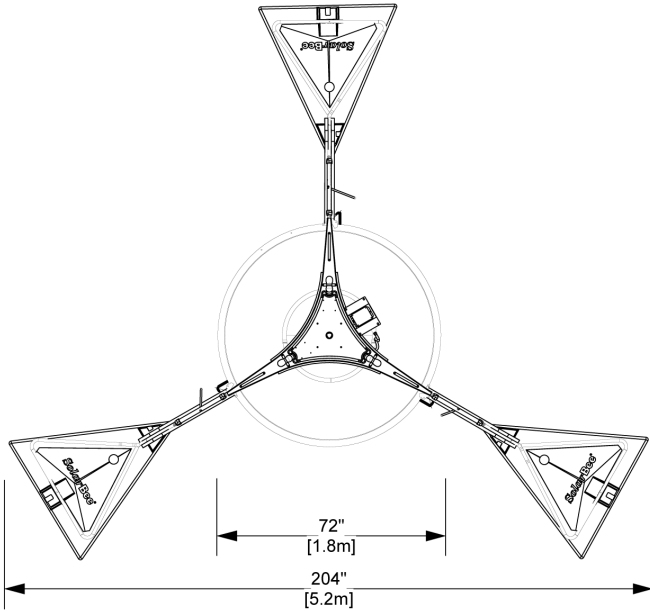

**Appendices**



**Appendix**

Additional Component Information

# Technical Data Sheets



# Technical Data Sheet

## GF10000

**Technology Description-** Floating, AC powered, circulation equipment for wastewater treatment and freshwater applications. Continuous operation on single-phase AC power.

**Materials of Construction** - T316 stainless steel constructions.  
Foam-filled high-density polyethylene (HDPE) floats.  
Thermoplastic rubber intake hose. HDPE Strainer.

### Flow Rates -

*Flow rates at full speed at 10 feet (3.0 meter) diameter*

Direct Flow Rate: 3,000 gpm (12,000 lpm)

Induced Flow Rate: 7,000 gpm (26,000 lpm)

Combined flow Rate: 10,000 gpm (38,000 lpm)

**Drive System** - High torque, direct drive (no gearbox), low voltage brushless D.C. motor.

**Minimum Water Depth** - Minimum of 30 inches (0.8m) operating depth required with fixed horizontal plate. No damage to machine or bottom of reservoir when run dry in shallow water.

**Flotation System** - Three floats in triangular pattern each with an adjustable float arm for proper vertical positioning, total float buoyancy of 1,200 lbs (550kg).

**Electrical Requirements** - Requires single phase 120VAC / 60Hz / 15 Amp Service. **(Not supplied by Ixom.)**

**Wiring Controls** - Includes power box which converts 120VAC to low voltage DC power. Includes submersible, SOOW type, cable with inhibitors for UV protection. SCADA accessory compatible.

**Rotating Assembly** - Removable assembly with easy access to motor and power box. Impeller handles 4-inch (10cm) spherical solids. Oil-filled (food grade) teflon freeze sleeve with o-rings, shaft. Rotational indicator on shaft.

**Fluid Intake Assembly - Option 1** - Hose system bolted to bottom of structural assembly.

**Hose System:** 10 to 100 feet (3 to 30.5m) available in 36-inch (91cm) diameter x 10, 15 or 20 feet (3, 4, 5 or 6m) sections.

**Intake Type :** Horizontal plate with 12-inch (31cm) openings.

**Intake Depth Adjustment:** 15 feet (4.5cm) of field adjustment with three SS chains connected to hose coupling.

**Fluid Intake Assembly - Option 2** - Fixed horizontal plate bolted to bottom of structural assembly.

**Intake Type :** Fixed horizontal plate with 12-inch (31cm) openings.

**Intake Depth Adjustment:** No adjustment necessary. Horizontal inflow from 25 in (64cm) below distribution dish.

**Fluid Intake Assembly - Option 3** - See GF10000DM Dual Mix Features Sheet.

**Anchoring** - Tethered to shore with SS cable.

**Ice Protection** - Freeze sleeve and positive pumping under distribution dish to maintain circulation.

**Accessories Available** - (1) Chemical Injection Kit (2) SCADA Accessories

### Shipping Size / Weight

• **Crate** - 87in x 87in x 65in (2.2m x 2.2m x 1.7m) / 1500lbs (680kg) *Exact weight and dimensions varies dependent on machine configuration.*

**Maintenance / Warranty** - Minimal maintenance. Limited 2-year parts and labor warranty.



Figure 1: GF10000

# Electrical Schematic

GF Series - G Box

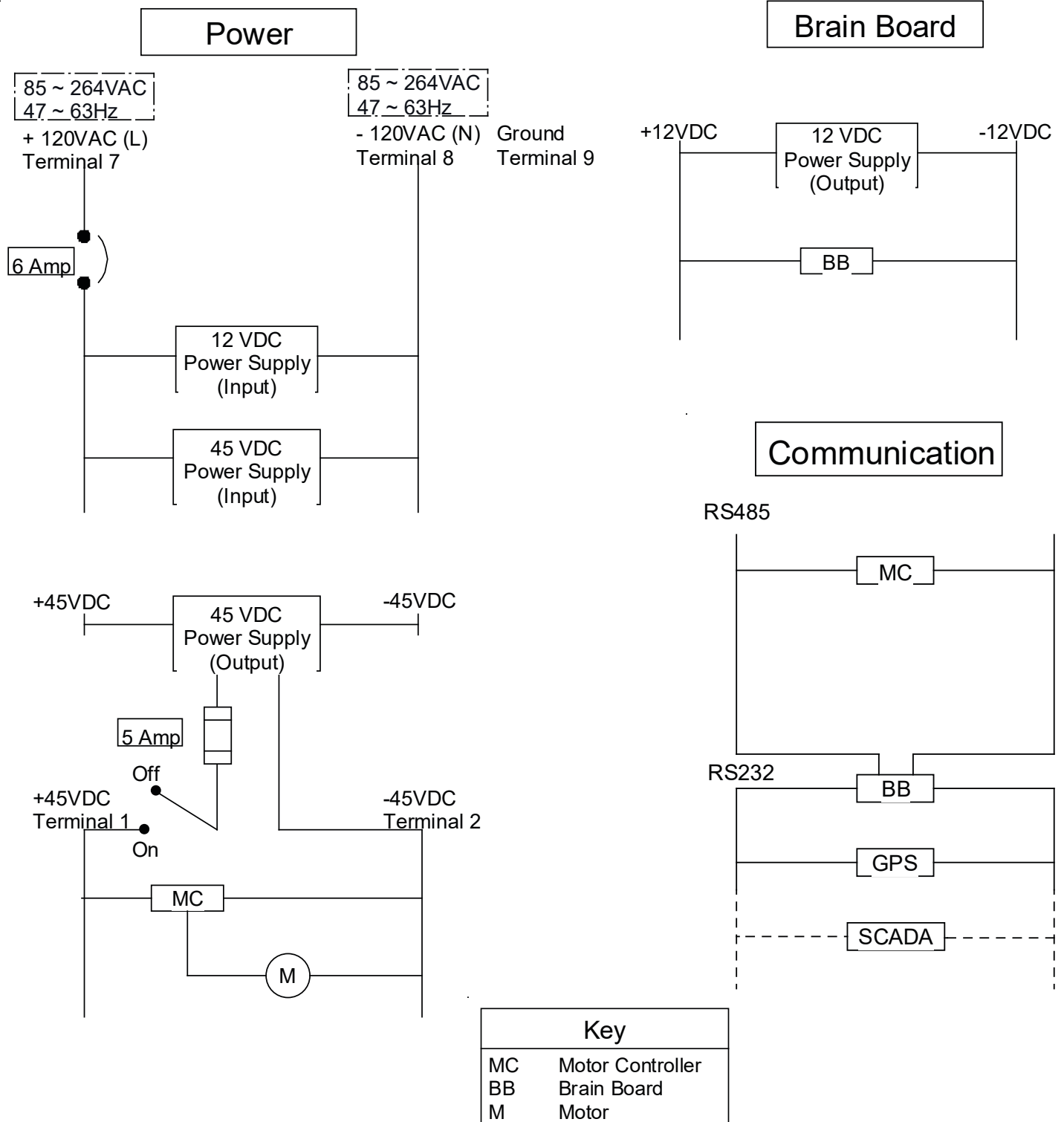

Key	
MC	Motor Controller
BB	Brain Board
M	Motor

## GridBee GF Series SCADA Output

The GridBee GF with SCADA package provides the following SCADA output capabilities: Controller shall have RS-232 serial communication (Modbus RTU), DB9 male connection point.

Parameters available for monitoring:

- 1) Motor RPM
- 2) Motor Direction
- 3) Motor Current
- 4) Visual Indicator Status

### SCADA Accessory Packages:

- Wireless Radio
- RS-232 to RS-485 Converter

---

## GridBee Monitoring Setup Information

The GridBee is a modbus RTU slave device with a factory programmable slave ID. The ID can be changed in the field with a properly programmed SD card. Contact Ixom Watercare, Inc. Customer Service for assistance.

### Serial Interface

Type: RS-232

Connector: 9 pin male D-Sub

Pin assignments:

- |   |                   |                      |
|---|-------------------|----------------------|
| 1 | n/c               |                      |
| 2 | RXD               | Receive Data Input   |
| 3 | TXD               | Transmit Data Output |
| 4 | n/c               |                      |
| 5 | Signal Ground     |                      |
| 6 | n/c               |                      |
| 7 | n/c               |                      |
| 8 | n/c               |                      |
| 9 | +12VDC, 1 Amp max |                      |
- (Can be used to power some serial devices)

### Serial/Modbus Communication Parameters

Rate: 19200 Baud

Bits/byte: 8

Stop bits: 1

Parity: N (none)

Handshake: None

Time between bytes sent to GridBee controller:  
No greater than 20 milliseconds

Time between commands sent to GridBee controller:  
At least 50 milliseconds

### Read Holding Register

The GridBee supports modbus Function 3 - Read Holding Register.

A properly formatted "Read Holding Register" modbus message will be replied to with holding register data. The "Read Holding Register" message consists of the GridBee slave address, the function (3), two bytes of register address, two bytes of number of points, and the CRC. The address of the holding registers can be found in the table below.

The format of the reply consists of the GridBee slave address, the function (3), a byte count (number of data bytes), two bytes of data for each of the requested points, and the CRC.

When monitoring several GridBees on the same modbus network, query them sequentially. That is, query one GridBee and wait for its response, query the next GridBee and wait for its response, etc. Querying the GridBees in a manner such that the query/response messages can overlap or collide will cause inconsistent communication.

## GridBee GF Series SCADA Output

### Description of Holding Registers in Order of Importance (Memory Table starts at zero, 0)

Register Address (Base 10)	Status Item	Description
0	NA	Not Applicable
1	NA	Not Applicable
2	NA	Not Applicable
3	NA	Not Applicable
4	Current Epoch High	<p>This is the date and time data for the GridBee. The format is the same as that of the "Unix epoch", (Epoch High * 65536 + Epoch Low), where the value is the number of seconds since 00:00:00 UTC on January 1, 1970. This value is set by the GPS hardware in the GridBee controller.</p> <p>Querying register 5 and testing the response against the previous value is a good way to monitor the communication link between the modbus master and the slave GridBee controller.</p>
5	Current Epoch Low	
6	NA	Not Applicable
7	NA	Not Applicable
8	NA	Not Applicable
9	Visual Status Indicator	<p>This value gives an indication of the GridBee controller health blink indicator. During normal operation the following values will appear:</p> <p>4 = (4 Blink Red = Healthy Operation)</p> <p>Any other indication requires attention:</p> <p>3 = (3 Blink Red = Motor Controller Communication Error)</p>
10	Motor Speed	The unit for this value is RPM in hundredths. To obtain RPM, divide the value by 100.
11	Motor Direction	The value of 0 indicates that the motor will be stopped, the value of 1 represents movement in the forward direction, whereas the value of 3 indicates reverse movement. Viewed from behind or above the motor clockwise motion is "forward".
12	Motor Current	The unit for this value is milliamps.

# System Status for GridBee GF SCADA

## Register Address 7 (Base 10)

Value of Zero indicates normal, healthy operation. Any other value indicates a subsystem or multiple subsystem errors. See below.

Binary Designation(s)	Decimal Value	Error Meaning
Bit 0 = 1	1	GPS Communication (Comm) Error
Bit 2 = 1	4	Motor Comm Error
Bits 0 and 2 = 1	5	GPS Comm and Motor Comm Error
Bit 3 = 1	8	Analog Out of Range (OOR) Error
Bits 0 and 3 = 1	9	GPS Comm and Analog OOR Error
Bits 2 and 3 = 1	12	Motor Comm and Analog OOR Error
Bits 0, 2, and 3 = 1	13	GPS Comm, Motor Comm, and Analog OOR Error

For Customer Service, contact Ixom Watercare, Inc. Office and Service Center at 866-437-8076.

**Table 4 - Visual Status Indicator (Register Address 9) - Priority Levels**

Priority Level	LED Behavior	Indication / Cause
Priority 1	3X Red	Motor Controller not communicating properly. If the Charge Controller has the Auxiliary Output turned off, this error is not displayed.
Priority 2	4X Red	Normal machine operation.



## Large 14" Brushless Motor

### Motor Features

**Technology Description-** Designed for Solarbee and Gridbee circulation equipment. The brushless direct drive motor provides high torque, eliminates costly gearboxes, and provides high reliability. The motor requires no brush replacement, no lubrication, and no routine maintenance. An iron free stator eliminates iron saturation to provide long life. It also provides a smooth, vibration free operation. Quite operation at low speeds. Operational power requirements utilize low voltage DC power. Using hall effects for electronic communication. Provides effective use of solar and DC energy.

14" Motor Specifications		
Size	14-inch (36cm) diameter X 6-inch (15cm) height	
Weight	75 lb (34 kg)	
Housing	Sealed 356-T6 Cast Aluminum	
Shaft	Stainless Steel: V-ring seal	
Thrust Bearing	L10: 100,000 hrs. Stainless Steel	
Motor Control	Anti-Corrosive coating on flux returns and magnets Encapsulated stator Conformal coating on commutation circuit board Hall Effect Commutation	
Receptacle	#16-9, 7A, 600V AC/DC, IP68, NEMA 6P, UL/CSA	
	<b>Normal Operation</b>	<b>Maximum Motor Ratings</b>
Current	<b>Less Than 1.0 Amp</b>	7.0 Amps
Voltage	<b>36 VDC</b>	36 VDC
Torque	<b>3ft-lb (0.4 N-m)</b>	30 ft-lb (40 N-m)
Power	<b>1/20 HP (36 W)</b>	1/3 HP (250 W)
Environment	<b>-40 to 140°F, freeze resistant, 100% humidity, splash and condensation resistant</b>	

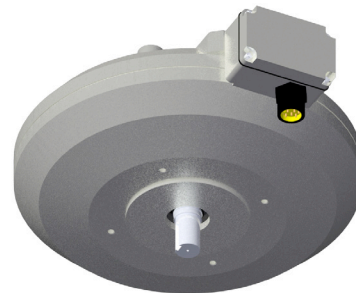

### Shipping Size/Weight

- 16" x 16" x 9", 80lbs.

**Maintenance / Warranty** - No routine maintenance. Limited 2-year parts and labor warranty.

## Warranty



### GridBee GF Mixers

#### Limited Replacement Warranty

**GridBee GF Mixers.** GridBee GF mixers and circulators are warranted to be free of defective parts, materials, and workmanship for a period of two years from the date of installation. GridBee SCADA and any optional accessories are considered “buyout” items for Ixom, and as such include a warranty against defects in material and workmanship for two years from the date of purchase. Parts that are determined by Ixom to be defective in material or workmanship under normal use during the two year warranty period will be repaired or replaced. Any shipping charges that may apply are the responsibility of the customer. A This warranty is valid only for GridBee equipment used in accordance with the owner’s manual, and consistent with any initial and ongoing factory ecommendations. This warranty is limited to the repair or replacement of defective components only and does not apply to normal wear and tear. If the factory’s service crews performed the original on-site placement and startup, then this warranty also includes labor. Where labor is included, in lieu of sending a factory service crew to the site for minor repairs, Ixom may choose to send the replacement parts to the owner postage-paid and may pay the owner a reasonable labor allowance, as determined solely by Ixom, to install the parts. There is no liability for consequential damages of any type. The warranty that is submitted and provided with the purchased equipment is the valid warranty.

**Terms applicable to all equipment.** This Limited Replacement Warranty is subject to the terms of Ixom’s General Terms and Conditions of Sale. In the event of any inconsistency between the terms of this Limited Replacement Warranty and Ixom’s General Terms and Conditions of Sale, the terms of this Limited Replacement Warranty shall prevail to the extent of that inconsistency.

# Protect Your Investment With The Ixom Service Program

## Comprehensive Damage Repair

Damage which occurs to your Ixom manufactured equipment in the normal course of operation will be repaired or replaced including supply and installation of structural repairs and replacement parts in accordance with Ixom's standard terms & conditions.

## Trained & Experienced Service Technicians

The Ixom Service Program allows our customers to take advantage of our highly trained service technicians. We have the equipment, experience and training to ensure the machines are well maintained while following OSHA regulations. Our dedication to safety and high level of training has earned us the prestigious SHARP recognition award time and time again. We have the means to safely service the equipment whether in municipal water tanks, lakes, reservoirs, or wastewater ponds & basins.



## Guaranteed Annual Onsite Maintenance

Ixom service personnel will perform a minimum of one (1) onsite equipment inspection & maintenance per yearly term of the service contract including mechanical, structural, and electronic components of Ixom manufactured equipment.

## On-Site Crew Response for Critical Application and Operational Service Issues

If service issues arise, the customer may be asked to perform a basic machine inspection and discuss results with Ixom's Customer Service Department. In some cases, the customer may be asked to perform minor tasks (i.e., cleaning, basic troubleshooting, and replacing minor parts). If replacement parts are needed, the factory will ship them out at no cost. For more serious application and service issues, Ixom will dispatch service personnel to resolve the issues onsite.



## Removal, Storage, and Redeployment of Equipment

For situations when Ixom equipment needs to be removed, stored, and redeployed, services can be offered at a discounted rate.

## Access to On-Staff Water Quality Experts

Ixom employs many experts in the water quality field including specialized areas such as limnology, hydrology, wastewater, biology, and engineering. Our water quality personnel are available for data analysis and troubleshooting when you need it.



## Contact us for a quote!

Call +1 866-437-8076 or email us at [watercare@ixom.com](mailto:watercare@ixom.com)

# IXOM

## WATERCARE

## Nationwide Installation & Service

### EVERYONE DESERVES GREAT CUSTOMER SUPPORT

Ixom Watercare earns customer trust with unparalleled service start to finish. Every department in Ixom is dedicated to the support of our Customers and the improvement of water quality. Complete life cycle support is much, much more than a returned phone call or an email. It centers around direct access and communication to those who can help when help is needed from the beginning of a project throughout the life of the equipment.

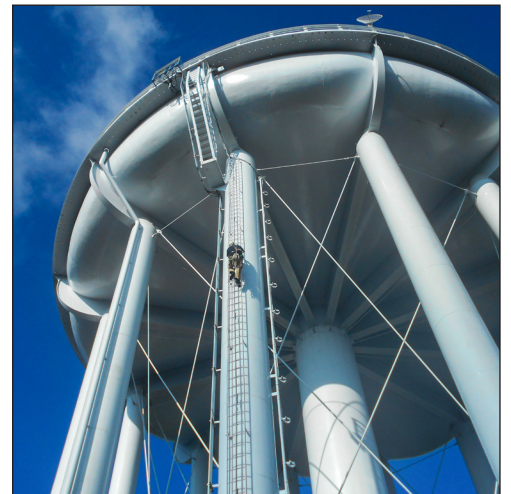

### ABOUT IXOM

Ixom combines innovative water quality solutions with top notch manufacturing and nationwide in-field service capabilities to create trusted, full circle support our Customers depend on.

We design and manufacture many trusted brands including GridBee®, SolarBee®, MIEX®, and ResidualHQ® for use across the water quality spectrum. This includes solutions for Water Treatment, Distribution Treatment, Wastewater Treatment and Lakes & Source Water Reservoirs.

Ixom has thousands of installations and is an industry-leader solving water quality problems across the United States, Canada and the world.

**Contact us today to discuss your water quality and service needs.**

[ixomwatercare.com](http://ixomwatercare.com)  
866-437-8076 • [watercare@ixom.com](mailto:watercare@ixom.com)