

SolarBee SB10000DM

Owner's Manual

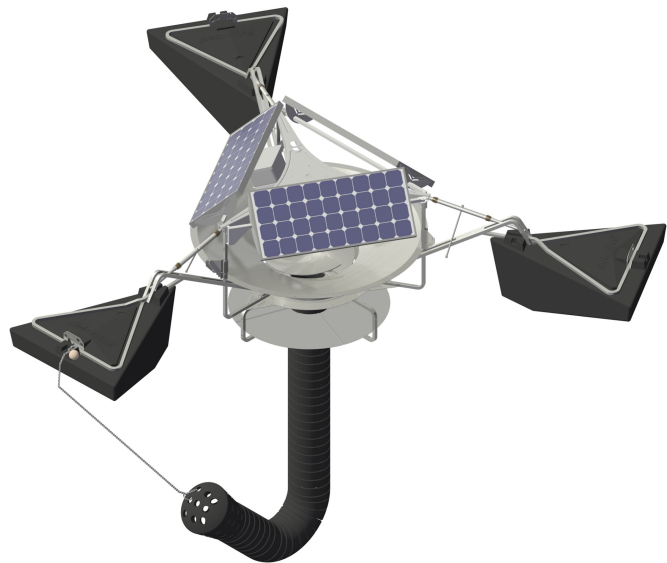

SolarBee SB10000DM

Owner's Manual

Safety	1
Operation	4
Features	5
Assembly	18
Maintenance	25
Electrical	38
Troubleshooting	40
Parts Diagram	44
Dimension Drawing	45
Appendix	46
Technical Specifications	47
Warranty	61
Service Program	62
Customer Service	63

Safety

IMPORTANT

**YOU MUST COMPLETELY
READ AND FULLY
UNDERSTAND THESE
INSTRUCTIONS BEFORE
INSTALLING, OPERATING,
OR SERVICING THIS UNIT.**

Be sure you have read all installation, operation, maintenance and safety instructions before you install, service or begin to operate this unit.

Accidents occur every year because of careless use of industrial equipment. You can avoid hazards by following these safety instructions, and applying some ordinary common sense when operating or servicing this unit.

Keep in mind that **full operator attention and alertness** are required when operating or servicing this unit.

USE COMMON SENSE!! Most accidents can be avoided by using **common sense and concentration** on the job being done.



Carefully read safety information when you see any safety symbols.

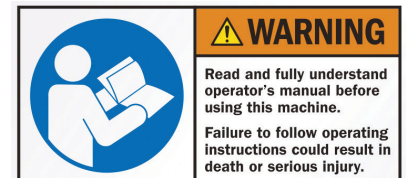

Safety

IMPORTANT

YOU MUST COMPLETELY READ AND FULLY UNDERSTAND THESE INSTRUCTIONS BEFORE INSTALLING, OPERATING, OR SERVICING THIS UNIT.

Identify all possible hazards. Determine what safeguards are needed and implement them. **Only you, the user,** understand your product and system characteristics fully. *The ultimate responsibility for safety is with you. Your safety ultimately rests in your hands.* Do your part and you will enjoy safe, trouble free operation for years to come. This instruction manual is not intended to include a comprehensive listing of all details for all procedures required for placement, operation and maintenance. If you have a question about a procedure or are uncertain about any detail, **Do Not Proceed.** Please contact Ixom Watercare Customer Service at **866-437-8076** to speak to a representative.



IMPORTANT!!!

Follow all federal and state laws in regards to safety regulations of working at heights, confined spaces, rescue, etc. as required by the U.S. Department of Labor, Occupational Safety and Health Administration. Use necessary PPE when placing and servicing this unit.



Thin Ice Hazard

WARNING: ICE SURROUNDING MACHINE MAY NOT SUPPORT WEIGHT, KEEP CLEAR OF THIN ICE.



ELECTRICAL HAZARD

WARNING: THIS EQUIPMENT CONTAINS HIGH VOLTAGE! ELECTRICAL SHOCK CAN CAUSE SERIOUS OR FATAL INJURY. ONLY QUALIFIED PERSONNEL SHOULD ATTEMPT PLACEMENT, OPERATION AND MAINTENANCE OF ELECTRICAL EQUIPMENT. REMOVE ALL SOURCES OF ELECTRICAL POWER BEFORE PERFORMING ANY SERVICE WORK TO THE MACHINE. USE PROPER LOCKOUT TAGOUT (LOTO) PROCEDURES TO ENSURE A SAFE WORK ENVIRONMENT.



Crush Hazard

WARNING: DO NOT REMOVE ANY FLOAT ASSEMBLY BOLTS OR PINS WHILE EQUIPMENT IS FLOATING IN WATER. EQUIPMENT MUST BE SECURELY SUPPORTED BEFORE PERFORMING SERVICE.



Rotating Hazard

CAUTION: KEEP BODY APPENANDAGES OR LOOSE CLOTHING AWAY FROM EQUIPMENT WHILE OPERATING. ENSURE EQUIPMENT IS OFF BEFORE ATTEMPTING SERVICE.



Entanglement Hazard

WARNING: ENSURE THAT PERSONNEL ARE CLEAR OF THE ELECTRIC CORD AND CHAIN TO AVOID ENTANGLEMENT.



Laceration Hazard

CAUTION: EDGES MAY BE SHARP AND CAUSE LACERATION IF PROPER CARE IS NOT USED.

Safety

Protect Yourself

It is important that you comply with all relative OSHA and local regulations while installing and performing any maintenance to the mixer circulation equipment.

Key OSHA Compliance Standards that must be followed (and not limited to) are:

- **1910.146 Permit-required confined spaces**
- **1910.147 Lockout/Tagout**
- **1926.500 Fall Protection**

Fall Protection Tips

- Identify all potential tripping and fall hazards before work starts.
- Look for fall hazards such as unprotected floor openings/edges, shafts, open hatches, stairwells, and roof openings/edges.
- Inspect fall protection and rescue equipment for defects before use.
- Select, wear, and use fall protection and rescue equipment appropriate for the task.
- Secure and stabilize all ladders before climbing.
- Never stand on the top rung/step of a ladder.
- Use handrails when you go up or down stairs.
- Practice good housekeeping. Keep cords, welding leads and air hoses out of walkways or adjacent work areas.

Refer to 29 CFR 1926.500 for complete regulations set by OSHA. Refer to your state's regulations if your state established and operates their own safety and health programs approved by OSHA.

Lockout Tagout

When the On/Off switch is in the "ON" position, the mixer may start up at any time if not already operating. The mixer's On/Off switch can be locked out by placing a pad lock thru the door latch of the controller after the switch has been turned to the "OFF" position. The On/Off switch is to be used as the emergency stop.



Permit-Required Confined Spaces

A confined space has limited openings for entry or exit, is large enough for entering and working, and is not designed for continuous worker occupancy. Confined spaces include underground reservoirs, ground storage tanks, elevated tanks, silos, manholes, and pipelines.

Confined Space Tips

- Do not enter permit-required confined spaces without being trained and without having a permit to enter.
- Review, understand and follow employer's procedures before entering permit-required confined spaces and know how and when to exit.
- Before entry, identify any physical hazards.
- Before and during entry, test and monitor for oxygen content, flammability, toxicity or explosive hazards as necessary.
- Use fall protection, rescue, air monitoring, ventilation, lighting and communication equipment according to entry procedures.
- Maintain contact at all times with a trained attendant either visually, via phone, or by two-way radio. This monitoring system enables the attendant and entry supervisor to order you to evacuate and to alert appropriately trained rescue personnel to rescue entrants when needed.

Refer to 29 CFR 1910.146 for complete regulations set by OSHA. Refer to your state's regulations if your state established and operates their own safety and health programs approved by OSHA.

Operation

Operation

SB Series

The SolarBee is designed to circulate water by bringing water from below and sending it out across the top in a thin layer causing a mixing effect. The laminar layer flows outward radially, in diverging “stream lines” from the distribution dish. As it does, vertical flow is induced in between the water being drawn below and the water above. At the level of the flow intake, water is drawn from all corners of the tank. As this lower layer of fluid makes its way inward with converging streamlines to the SolarBee, the water is forced upward, toward the surface, providing gentle mixing and de-stratification.

The SolarBee obtains all the energy it needs from the sun. Its solar panels provide power to the onboard battery which energizes the drive system’s controls and motor. Excess solar energy is stored during the day and used during the night allowing the SolarBee to operate during the night without being connected to the grid.

During operation, a visible flow can be observed coming off the distributor dish and spreading outward. The impeller of the SolarBee is designed to operate at full speed when there is sufficient sunlight and battery charge. The rpms may drop down some during the later night and early morning when the battery uses up its charge after a longer period of overcast days. In severe sunlight limited conditions, the machine may slow down or stop temporarily to protect the battery from damage.

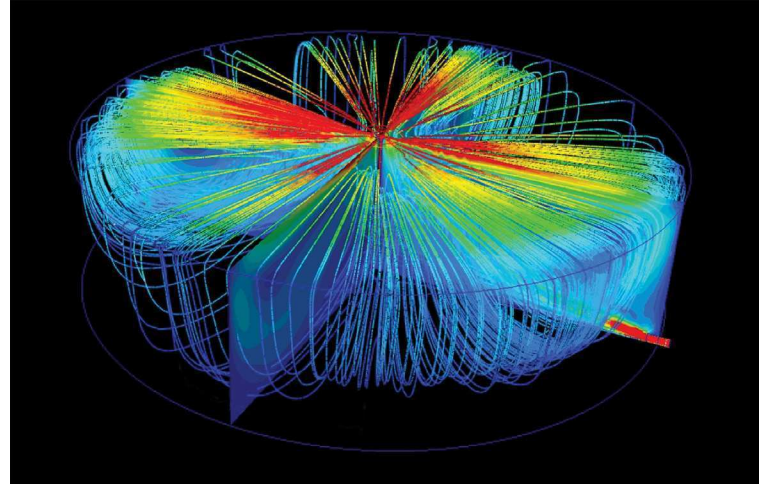

SolarBee Series Flow Model

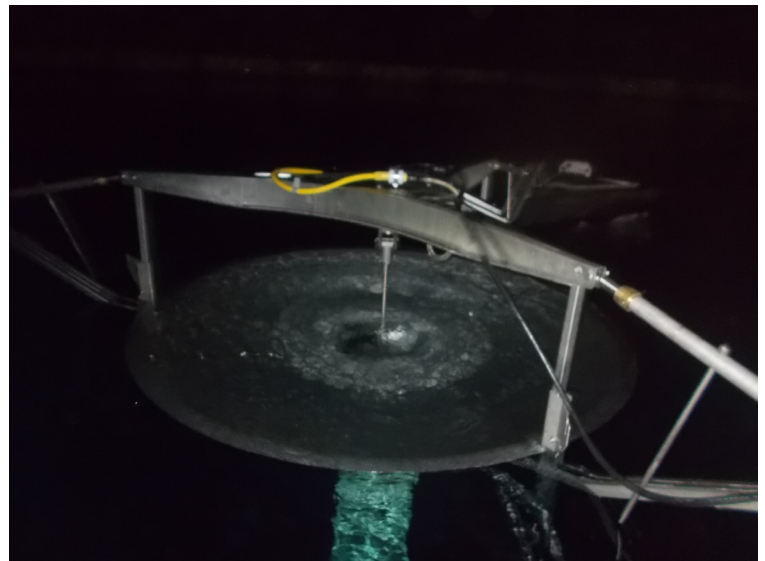

Flow Coming Off Distribution Dish

Features

Features

SB Series Large Frame Mixers

The SolarBee with technology includes new features which enhance its performance through more efficient and durable components, improved operation monitoring capabilities, easy component access, and a robust frame structure.

Solar / Electronics

Photovoltaic (PV) Modules -The PV modules are often referred to as the solar panels. The SolarBee uses 100% solar energy to provide day/night operation. The PV modules collect solar power to operate the machine with excess left over to charge an onboard 12-volt, deep cycle battery. The SolarBee has 3 80-watt PV modules which individually connect to the digital controller. A bird deterrent is located directly above the PV modules to prevent bird fouling.

The PV modules have 3 angle settings that are set at the factory based on solar energy availability unique to the customer's geographic location. The flattest position is a 35 degree angle for customers located where solar power availability is greatest. The mid-range setting position is a 45 degree angle for customers where solar power availability is moderately available. The steepest position is a 55 degree angle intended for winter conditions to prevent snow and ice buildup from lasting a long time period on the PV modules (following winter conditions, the PV modules should be returned to their original position to maximize solar energy collection).

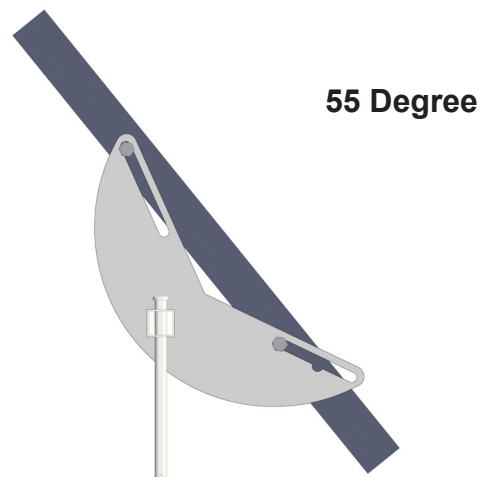
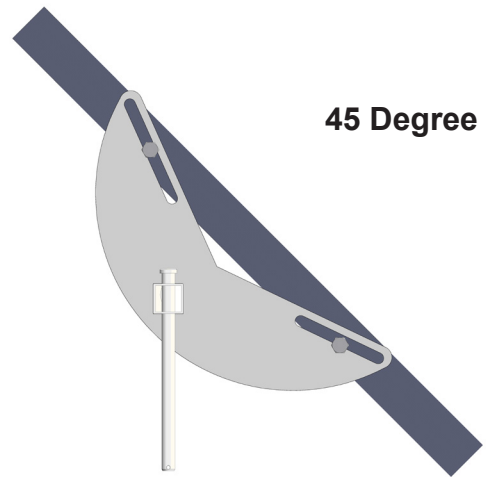
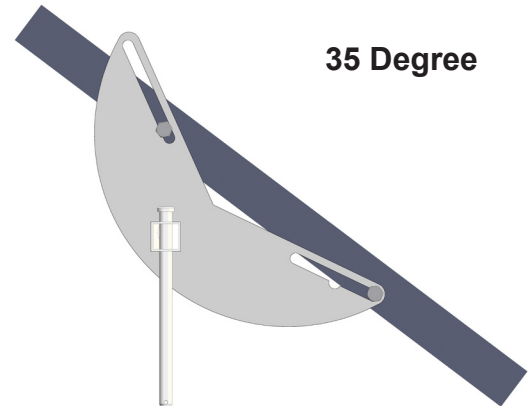

Features

Features

SB Series Large Frame Mixers

For cable tethered anchoring, the north facing panel may be flipped to face the south using a special panel gate. A tethered machine is fixed and will not rotate, so the north facing panel will receive the least sunlight, unless flipped using the special gate. For mooring block anchoring, this is not an option due to the machine rotating about the mooring blocks.

Each PV module is fixed to a gate that opens up allowing quick access to the interior components of the machine. Each gate opens by simply removing a pin on the latch end.

Onboard Battery - The onboard battery is located directly below the dish in a stainless steel compartment. During operation, the battery is submerged in the water to maintain a stable-temperature environment that increases its performance and life. The battery is double walled to isolate its contents from the water it is submerged in.

The onboard battery stores excess power from the solar panels during the day and operates the machine using the stored power during the night and extremely overcast days.

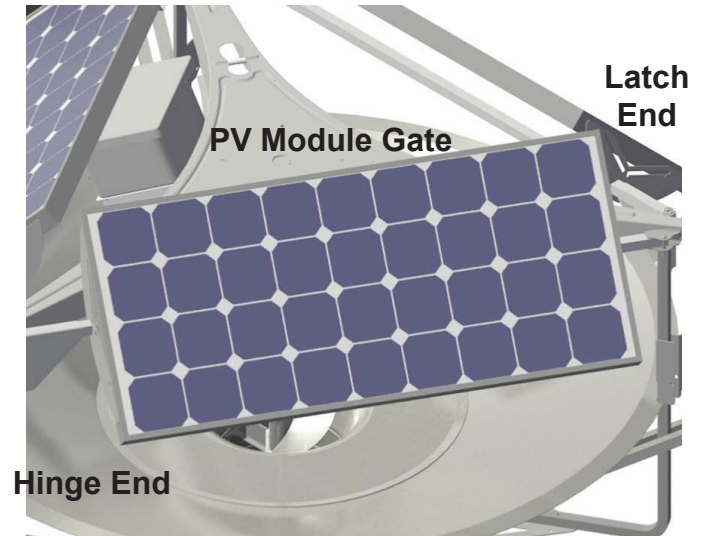

Onboard Battery

Features

Features

SB Series Large Frame Mixers

Digital Controller - The digital controller is located near the top center of the SolarBee. The digital controller can be easily accessed by opening the PV module gate directly above and in front of it. The digital controller is constructed with a NEMA 4X (IP 66) Enclosure.

All solar energy collection and motor operation are managed by the digital controller. This component has two primary functions: (1) To direct and divide the power being collected by the PV modules between the brushless motor and battery. (2) To serve as the main control center that operates the brushless motor.

There are 3 PV module connections located on the front face of the digital controller. If the onshore power accessory was purchased, a connection will be located on the right side face. The onshore connection is used only in applications where onshore grid power is desired.

The left side face of the digital controller contains the brushless motor connection, battery connection, and On/Off switch. The On/Off switch activates power to the motor. When the switch is turned to the Off position, the motor will not operate. The charging function of the controller will continue to charge the battery even when the switch is turned off.

MODEL MAY VARY

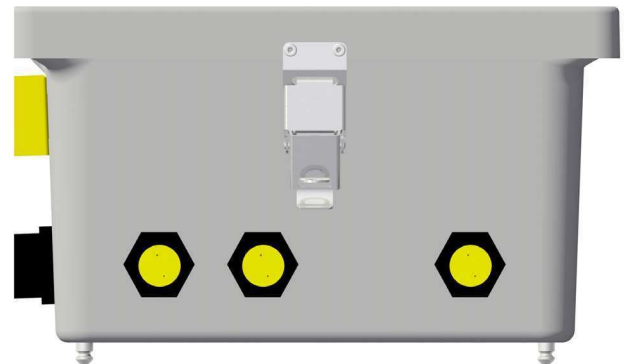
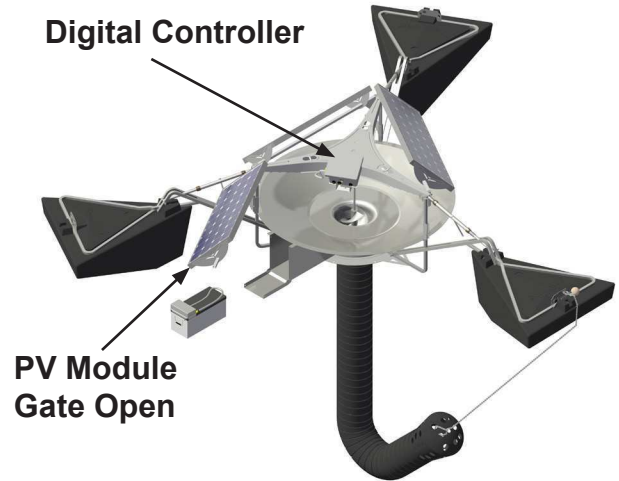

Front Face Of Digital Controller

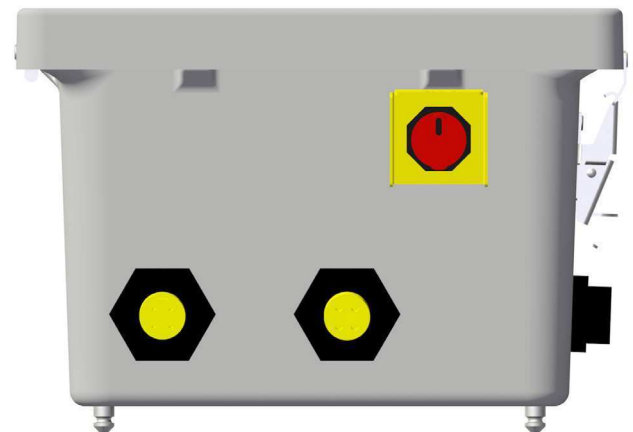

Left Side Face Of Digital Controller

Features

Features

SB and GF Large Frame Mixers

SCADA outputs offering machine operation parameters reside within the digital controller. Please contact us if you are interested in receiving these parameters.

Motor Controller - The motor controller is located near the motor just below the top plate of the Machine. The motor controller is sealed in line with the electrical cord that runs to the brushless motor.

The motor controller on the Machine receives power and signals from the main control center located inside the external enclosure. These signals are used to operate the brushless motor at the commanded speed. The motor controller also sends feedback signals back up to the main control center.

Due to the high frequency of communication between the motor controller and brushless motor, the two components need to be located close to one another. This is the primary reason for having the motor controller located directly on the Machine.

All electronic connections on the Machine equipment should only be used for the inputs or outputs that they are labeled and designed for. If any of the leads going into the electronic controller are disconnected, be sure when re-connecting to place them in the proper position.

Wiring - All electric wiring includes corrosion-resistant, industrial cords with molded, weather and watertight connectors. The connectors are indexed to prevent improper wiring. A general electrical schematic can be found in the Maintenance and Field Adjustment section.

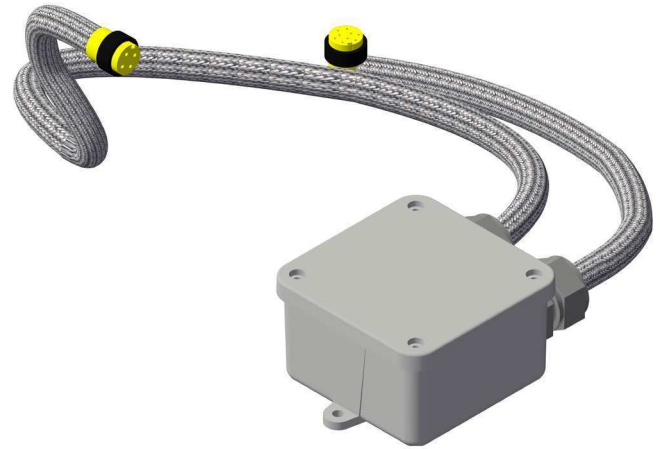

Motor Control Cord

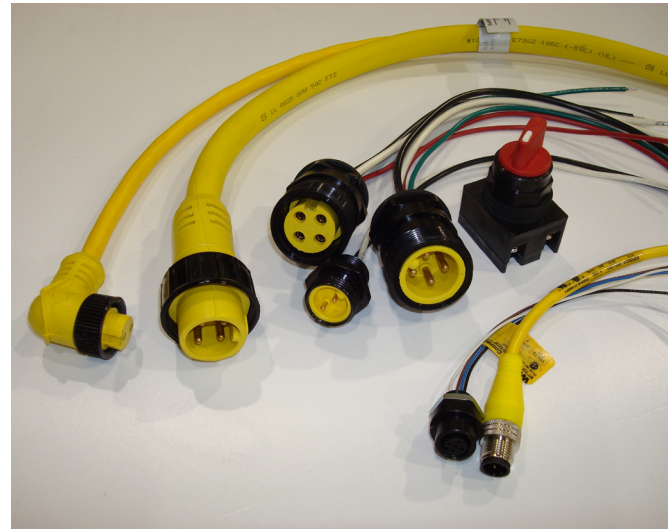

Durable Wiring And Connectors

Features

Features

SB and GF Large Frame Mixers

Brushless Motor / Impeller

Brushless Motor - The brushless motor is located directly below the Top Deck. 4 bolts run down through the Top Deck and into the housing of the brushless motor fastening it onto the machine.

The brushless motor is built to be very durable. The housing is constructed of casted aluminum. The brushless motor runs very quietly and smoothly. It does not require any maintenance. A drive shaft extends through the bottom center of the housing.

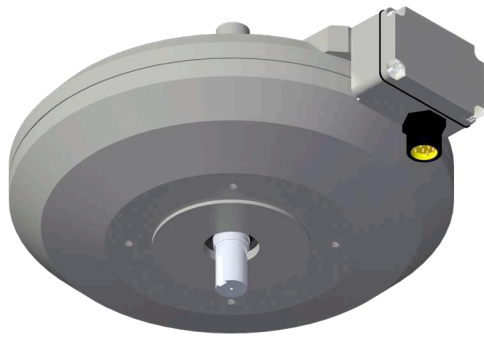

Brushless Motor



CAUTION: THE BRUSHLESS MOTOR WEIGHS APPROXIMATELY 80 LBS (36KG). DO NOT REMOVE WITHOUT DISCUSSING THE PROCEDURES AND EQUIPMENT NECESSARY WITH A SERVICE TEAM MEMBER.

Shaft Coupling - The shaft coupling connects the brushless motor drive shaft to the impeller shaft. The shaft coupling is located directly below the brushless motor and is made up of 3 main components. These components are called the upper coupling, lower coupling, and coupling sleeve. The shaft coupling is designed to allow quick disconnect for removal of the impeller assembly. Disconnecting the impeller shaft from the brushless motor shaft is simply accomplished by pulling out a pin and requires no tools. The upper coupling remains attached to the brushless motor while the lower coupling and coupling sleeve remain on the impeller shaft.

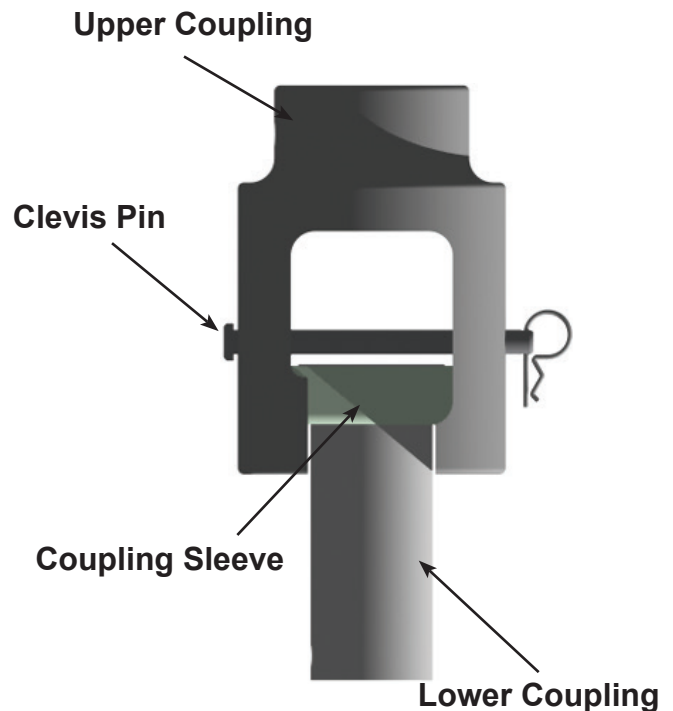

Features

Features

SB and GF Large Frame Mixers

Impeller Assembly - The impeller assembly is made up of the stainless steel impeller shaft, stainless steel flag indicator, freeze sleeve, stainless steel impeller blades, and plastic impeller bushing. The impeller assembly is easily removed by pulling a pin on the shaft coupling.



CAUTION: KEEP BODY APPENDAGES OR LOOSE CLOTHING AWAY FROM THE IMPELLER ASSEMBLY WHILE THE MACHINE IS OPERATING! IF MAINTENANCE IS REQUIRED, BE SURE TO TURN THE MACHINE OFF FIRST!

The flag indicator is fixed to the shaft and used as a visual indicator of the impeller shaft's rotational speed.

An food grade oil-filled, Teflon freeze sleeve secured with o-rings surrounds the impeller shaft. The freeze sleeve is free to rotate on the shaft. If the water should freeze around the machine, the freeze sleeve will stand still, frozen in by the ice, but inside the plastic sleeve, the impeller shaft will be turning.

The impeller blades are welded to a hub that is securely fastened to the impeller shaft. The impeller is designed to gently pump water from below and can handle up to 4-inch (10cm) spherical solids.

The impeller bushing is a smooth collar that the impeller shaft tip fits into. The impeller bushing aligns and centers the impeller shaft within the machine.



Turn Machine Off Before Performing Maintenance
Impeller Assembly

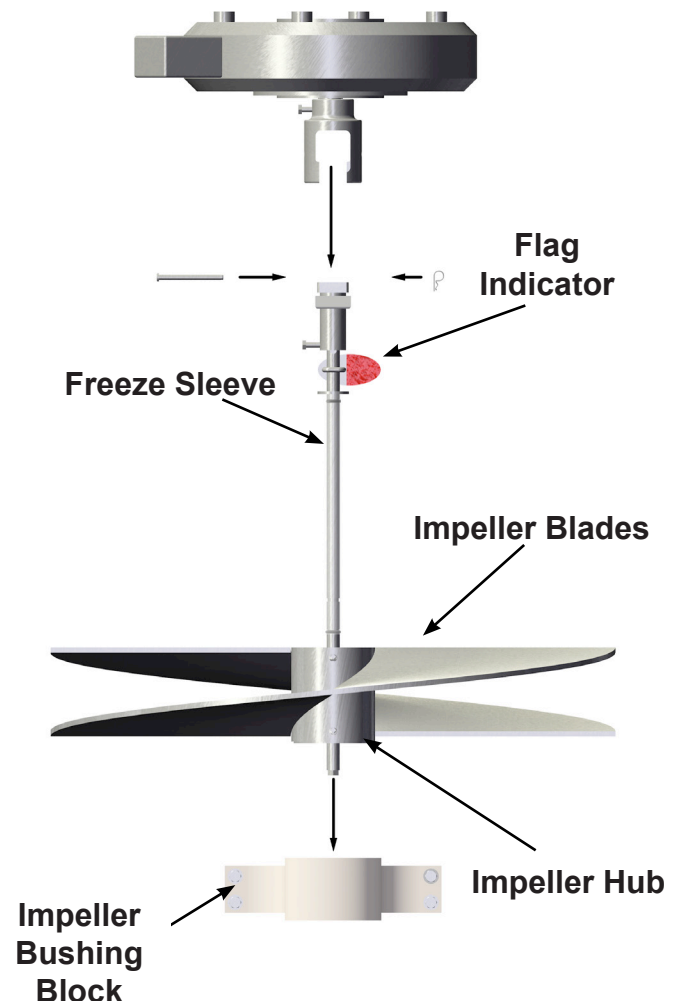

Features

Features

SB and GF Large Frame Mixers

Distributor Dish

The distributor dish, structural members, structural fasteners, and mounting brackets are constructed of stainless steel.

Distributor Dish - Near-laminar flow is achieved by the Machine due to its uniquely designed distributor dish. The impeller rotates while sitting within the lower half of the distributor dish. There are also small water passages located below the dish to strengthen the induced flow effect (water movement occurring between the lower water layer entering the machine and the upper water layer leaving the dish).

The top lip of the distributor dish is set from 3/4 inch to 2.5 inches (2 cm to 6.4 cm) (**Please refer to the table below for exact settings**) below the surface of the water to achieve best flow results. The distributor dish depth is set by rotating the turnbuckles located on the float arms.

MODEL MAY VARY

Distributor Dish

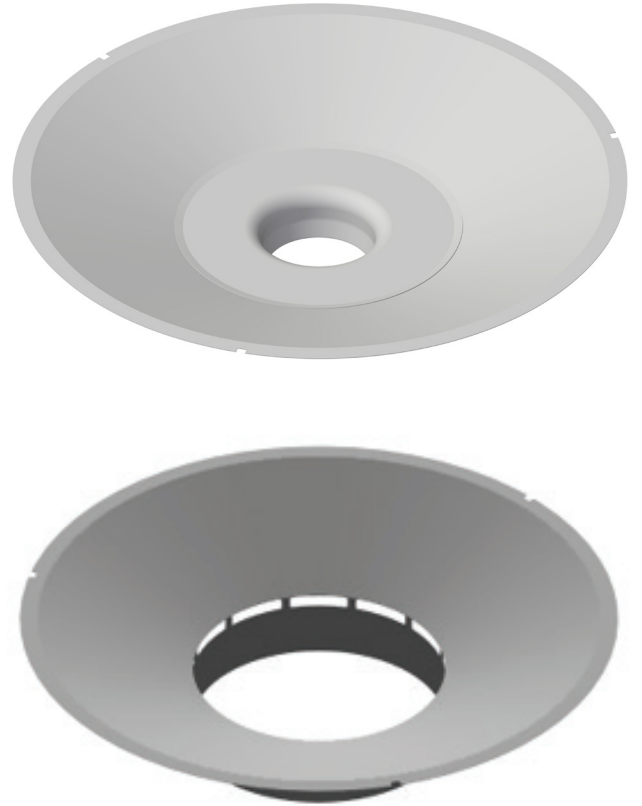

Machine Model	Water Level
2500	3/4 in to 1 in (2 cm to 2.5 cm)
5000	1 in to 1 1/2 in (2.5 cm to 3.8 cm)
7500	2 in to 2 1/2 in (5.1 cm to 6.4 cm)
10000	2 in to 2 1/2 in (5.1 cm to 6.4 cm)

Features

Features

SB and GF Large Frame Mixers

Hose / Strainer - The hose is directly below the distributor dish and the strainer is located at the end of the hose. The strainer contains a buoyant float ball inside that allows the strainer to draw water from approximately 1.5 ft to 2 ft (0.45m to 0.6m) above solid bottom. The hose is designed to make a "J" shaped bend at the bottom so that the strainer does not draw sediment up from the bottom. The strainer has a chain connected to it and can be chained up at more shallow depths if necessary. The chain also is used for pulling up the strainer to check it for plugging.

Hose and Strainer Configuration - MODEL MAY VARY



SB2500



SB5000



SB7500

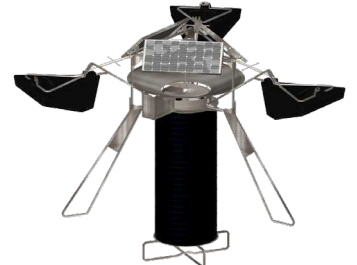

SB10000



GF2500



GF5000



GF7500



GF10000

Features

Features

SB and GF Large Frame Mixers

Float Arms / Floats

The Machine contains 3 float arms and 3 floats. The float arms allow vertical positioning of the machine and the floats provide buoyancy.

Float Arms - The float arms are constructed of stainless steel components. They connect the floats to the central machine structure. Each float arm has a sturdy turnbuckle. The turnbuckles can easily be rotated to adjust the vertical height of the distributor dish. Lengthening the turnbuckle (rotating clockwise) will raise the lip of the distributor dish, whereas shortening the turnbuckle (rotating counter-clockwise) will cause the lip of the distributor dish to lower.

The turnbuckle and float arm structure components are constructed with robust stainless steel materials allowing the Machine to operate in severe environments without being damaged. The turnbuckle is self locking. Simply rotate the handle to expand or collapse the turnbuckle for dish depth adjustment.

It is important to check the distributor dish depth routinely. The Machine naturally drops into the water over time due to biomass buildup and trapped air escaping from the hose. If the distributor dish lip is too high, the water coming off the lip may become turbulent and the flow rate of the machine may be reduced.

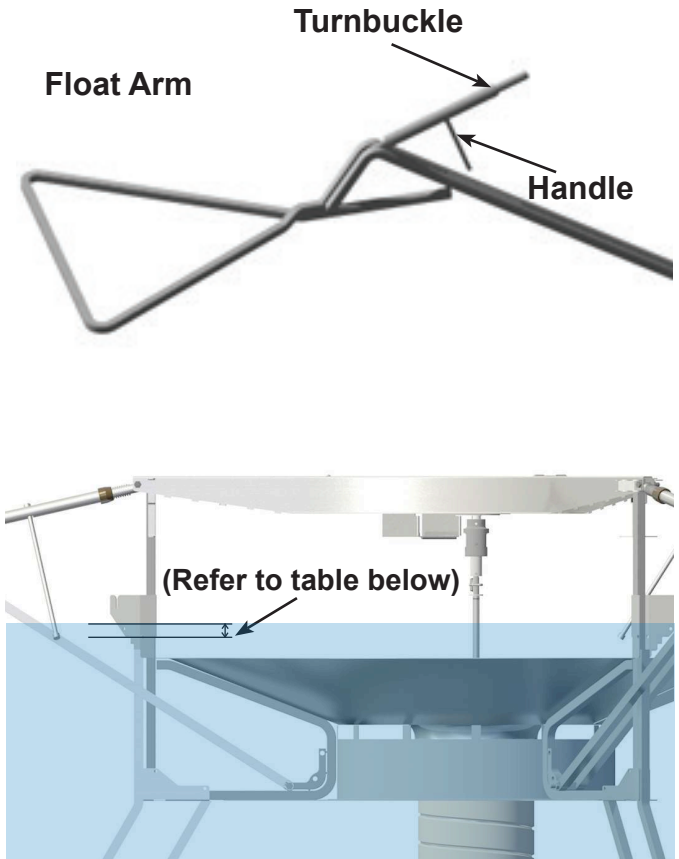

Distance Between Distributor Dish And Water Level

WATER LEVEL NOTCH SETTING FOR:

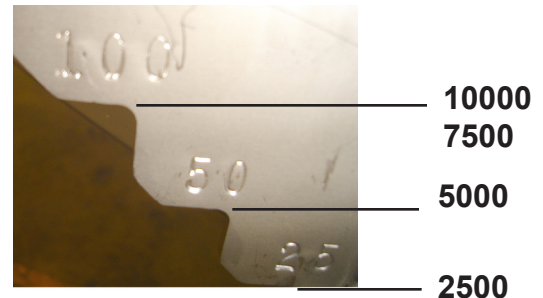

Dish Depths For Different Models

Machine Model	Water Level
2500	3/4 in to 1 in (2 cm to 2.5 cm)
5000	1 in to 1 1/2 in (2.5 cm to 3.8 cm)
7500	2 in to 2 1/2 in (5.1 cm to 6.4 cm)
10000	2 in to 2 1/2 in (5.1 cm to 6.4 cm)

Features

Features

SB and GF Large Frame Mixers

If the distributor dish lip is too low, the water coming off the lip will flow just underneath the surface of the pond and the surface will not be renewed.

Each float arm is connected to the central machine structure with 1 bolt and 1 pin. Each float is connected to the float arm by 2 pins. The turnbuckle can be removed from the float arm by pulling a pin, but should only be done when the unit is resting on the shore.

If re-attaching the turnbuckle to the float arm, be sure that each threaded end of the turnbuckle together are screwed all the way in or all the way out before re-attaching. If threaded ends are not equally expanded or collapsed before fixing the ends, the turnbuckle will have limited adjustment.

Floats - The Machine has 3 floats, made from high density Polyethylene. The floats are filled with a Polystyrene closed-cell foam for long term buoyancy. The floats have a uniquely designed shape to:

- Minimize the interference with the water flow on the surface coming off the distributor dish.
- Have a low profile above the water for minimizing wind resistance and offering less exposure to vandalism.
- Avoid being crushed by ice pressure.
- Provide extra buoyancy when needed without going much deeper into the water.

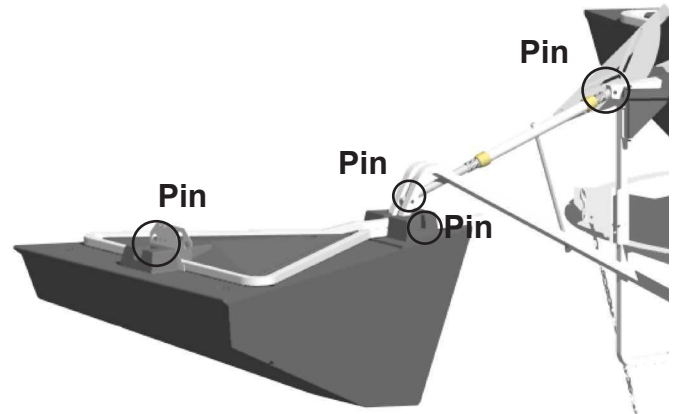

Float Arm Connection Points



CAUTION: DO NOT REMOVE ANY FLOAT ASSEMBLY PINS OR BOLTS WHILE THE MACHINE IS FLOATING IN THE WATER! THE MACHINE MUST BE RESTING ON THE GROUND OR SAFELY SUPPORTED TO RELIEVE THE FORCES ON THE FLOAT ASSEMBLY STRUCTURES PRIOR TO DISASSEMBLY! FAILURE TO FOLLOW THIS WARNING COULD LEAD TO SINKING THE MACHINE OR SERIOUS INJURY!

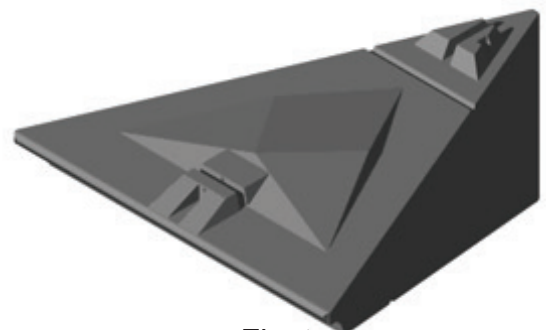

Float

Features

Features

SB Large Frame Mixers Anchoring Systems

Anchoring Systems

The SolarBee uses one of the following anchoring systems. The mooring block system consists of submerged anchors and doesn't require lines running from the shoreline. The tethering system uses cable that spans across the pond or reservoir connecting to tethering posts on the shoreline.

Mooring Block System - The mooring block system consists of two mooring blocks made of high density Polyethylene with smooth, rounded bottoms. The smooth bottoms prevent any damage being done to a pond liner or reservoir bottom. The mooring blocks are concrete filled and weigh approximately 70-lbs. (32 kg).

Stainless steel anchor chain is used to connect the mooring blocks to the SolarBee at the float plate on one of the floats. The anchor chain contains swivels approximately every 15-ft (4.5m) to prevent the chain from twisting and tangling.

A 7:1 scope is generally preferred for the length of anchor chain. For example, if the pond is approximately 10-ft (3m) deep, the anchor chain will go from the first mooring block out 70-ft (21m) to the machine. The 7:1 scope prevents the machine from moving during high wind and wave conditions. The two mooring blocks are generally spaced apart along the anchor chain by a distance approximately the depth of the water. From time to time, as determined by specific circumstances, the scope can be reduced to 5:1.



Mooring Blocks

Movement of machine - For a SolarBee anchored by a mooring block system, the machine may rotate 360 degrees around the mooring blocks on a radius of approximately 5X to 7X the water depth. For example, a machine that is in 10 ft (3m) of water may travel on a 70 ft (21 m) radius from the location of the mooring blocks.

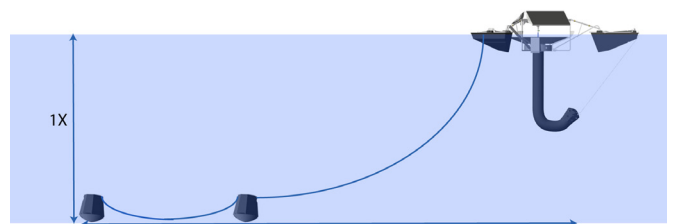

Mooring Block System (7:1 Scope)

Features

Features

SB Large Frame Mixers Anchoring Systems

Following severe weather conditions (greater than 80-mph (129 km/hr) wind, higher than 4-ft (1.2m) waves, or ice thaw), it is possible for the SolarBee to drag the anchors and move out of position. If this should happen, the pond or reservoir operator will need to re-locate the machine to its original position.



WARNING: IF MOVING OR DEPLOYING MOORING BLOCKS CONNECTED TO THE ANCHOR CHAIN, BE SURE THAT YOU AND OTHERS ARE CLEAR OF THE ANCHOR CHAIN BEFORE SINKING THE MOORING BLOCKS! LOWER THE MOORING BLOCKS INTO THE WATER SLOWLY. FAILURE TO DO SO COULD CAUSE SERIOUS INJURY OR DEATH BY DROWNING!

Tethering System - The tethering system consists of 2 tether posts or duckbill anchors set into the shoreline across from one another. A stainless steel cable is strung across the pond or reservoir and tied to both tether posts. The SolarBee has 2 short chains running from two of the float plates on the machine out to the cable line running across the pond or reservoir.

The tethering system is used in applications where the body of water is very narrow or the Mooring Block System is not applicable. Following severe weather conditions (greater than 80-mph (129 km/hr) wind, higher than 4-ft (1.2m) waves, or ice thaw), it is possible for the tether posts to pull partly or completely out of the ground. If this should happen, the pond or reservoir operator will need to re-locate the machine to its original position.

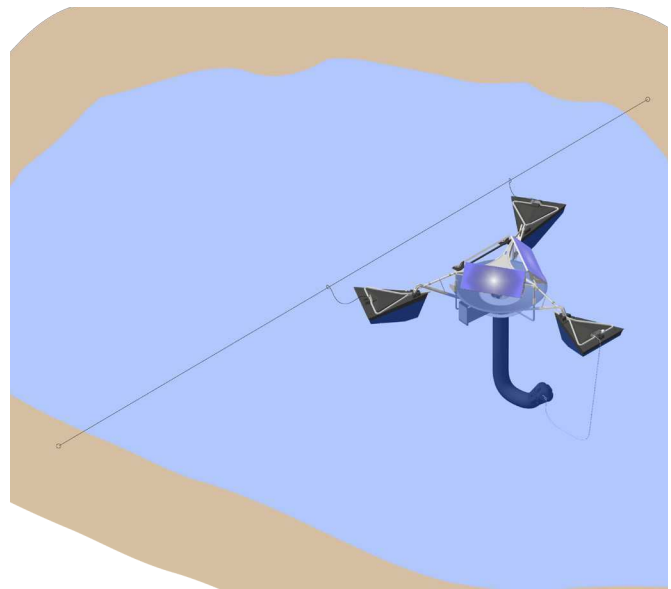

Tethering System

Movement of machine - For a SolarBee anchored by a tether system, the machine will have limited movement, however slack will be left to allow for water fluctuation. The tether line slack will be field determined based on tether line span and expected water fluctuation. The SolarBee will not rotate when it is anchored using the tether system.

Tethering Deployment

Duckbill Anchors

Duckbill Anchoring Deployment

for Tethered SolarBee / GridBee Machines

Verify that One-Call has been called and that buried lines have been marked.

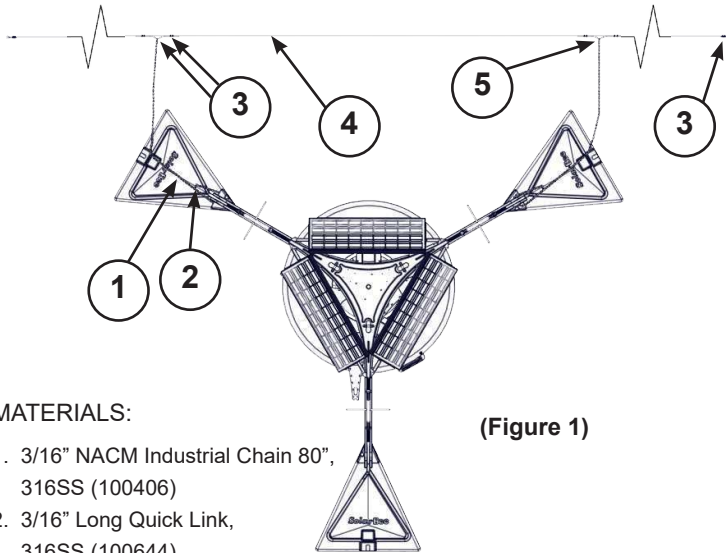

MATERIALS:

1. 3/16" NACM Industrial Chain 80", 316SS (100406)
2. 3/16" Long Quick Link, 316SS (100644)
3. Cable Clamp, 3/16" (12010412)
4. 3/16" cable, 316SS (10014018)
5. 3/16" cable loop, 316SS

(Figure 1)

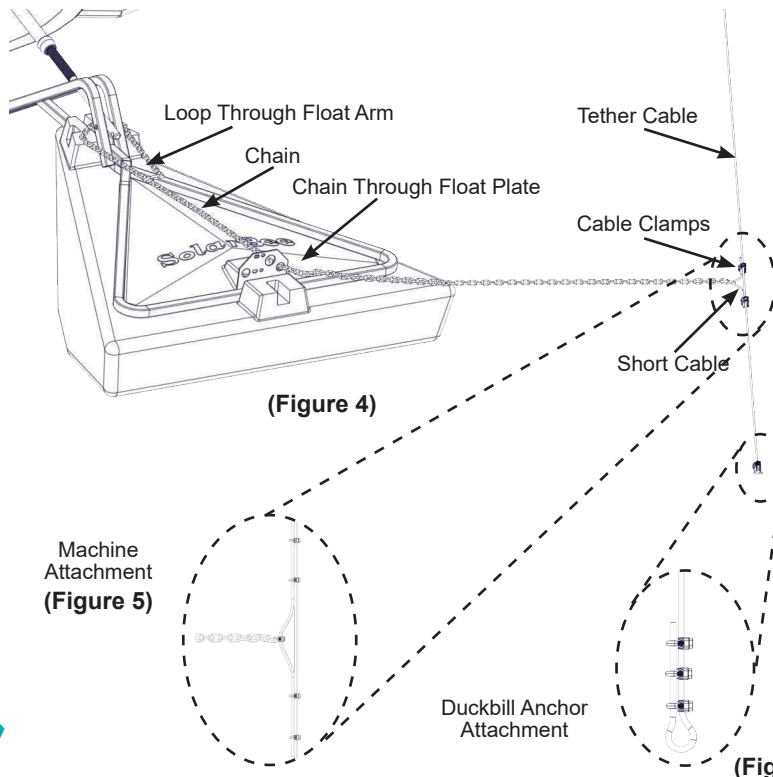

(Figure 4)

Machine Attachment (Figure 5)

Duckbill Anchor Attachment (Figure 6)

(Figure 6)

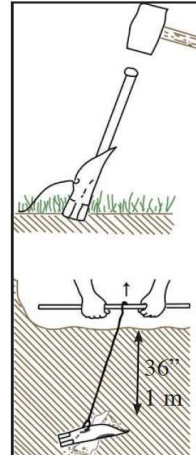

(Figure 2)

Rated for 3000 lb (13.3 kN) load.

Set at a depth of 3 ft (1m).

1/4" (6.35mm) SS Cable, 42" (1m) L

Aluminum Alloy 356 Duckbill

2 Duckbill anchors per Machine

TOOLS REQUIRED:

- (1) Sledge Hammer
- (1) Ø 5/8" or Ø 7/8" Steel Driving Rod
- (1) Pliers
- (2) 10 mm wrench and/or socket

STEP 1: Set two duckbill anchors across the pond from one another so that the center of a straight line between the two anchors is the approximate location that the SolarBee/GridBee will be placed. (Figure 1)

STEP 2: Drive in the duckbill anchors into the ground at desired location using a 5/8" or 7/8" rod. (Figure 2)

STEP 3: Tie off the tether cable to the eye loop of the duckbill anchor. Use 10 mm wrench to tighten both nuts on each cable clamp. (Figure 3 & 6)

STEP 4: Secure one end of the tether cable across the pond and tie it off to the other anchor leaving some slack/droop in the line. (See Figures 1, 3 & 6) The slack is for water fluctuation. If the pond has a large range of fluctuation, more slack should be left.

STEP 5: Secure short chain to the SolarBee float arm and the other end to the tethering cable. (Figure 4 & 5) Tighten quick link on float arm side using pliers. Tighten cable clamp side using 10 mm wrench.

STEP 6: Repeat step 5 for the second short chain and float arm.

CORRECT WIRE ROPE CLIP PLACEMENT



RIGHT WAY FOR MAXIMUM ROPE STRENGTH

(Figure 3)

Float Assembly

After familiarizing yourself with all the components and gathering the necessary tools, you are ready for setting up the Machine. Find a location where you have approximately 20 ft of working space near the reservoir that the Machine will be put in (The less distance you have to move the fully assembled machine, the better). Follow these steps to prepare the Machine before floating it in the water:

NO TOOLS REQUIRED

STEP 1: Locate one float, one float arm, one float bracket, and 2 float pin sets. Observe that there are two slots on the top of the float which fit around the float arm. One slot runs left and right, the other runs front to back. If float pins are in the slots, remove them.

STEP 2: Orientate the float so that it will fit around the float arm when the float is raised into place.

STEP 3: Place the float plate into float slot 1 furthest from the core unit assembly aligning the holes of the float slot with the small holes on the float plate (see photo).

STEP 4: Once the float plate is in place on the float, raise the float up fitting it into the float arm. Use the float pins to secure the float to the float arm.

STEP 5: Place hairpins in each float pin to secure it and prevent the pin from coming out.

STEP 6: Repeat Steps 1 through 5 for the other two floats.

NOTE: The float plate may not be used on one of the three floats.

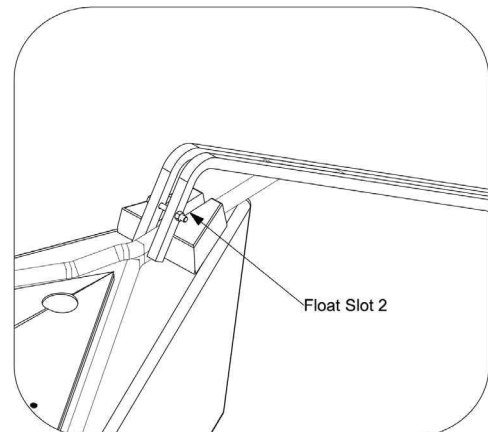
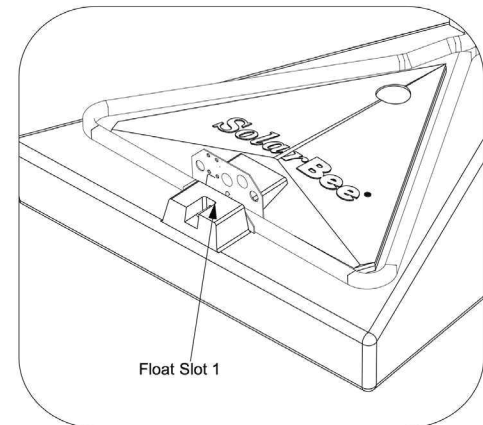
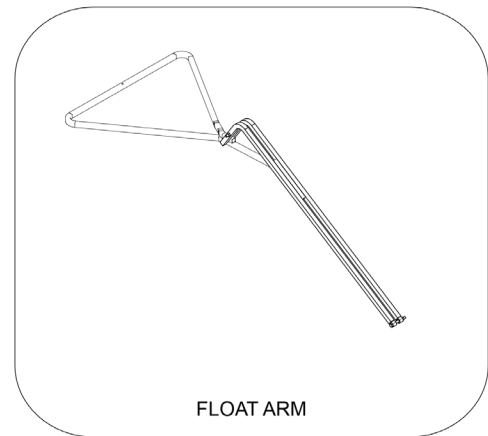

Float Arm to Machine Attachment Assembly

IMPORTANT: IF WRONG CONNECTION HOLE IS USED, DISH DEPTH LEVEL MAY NOT BE OBTAINED DURING FINAL SETTINGS AND UNIT WOULD HAVE TO BE PULLED BACK OUT OF THE WATER, CORRECTED, AND RE-INSTALLED

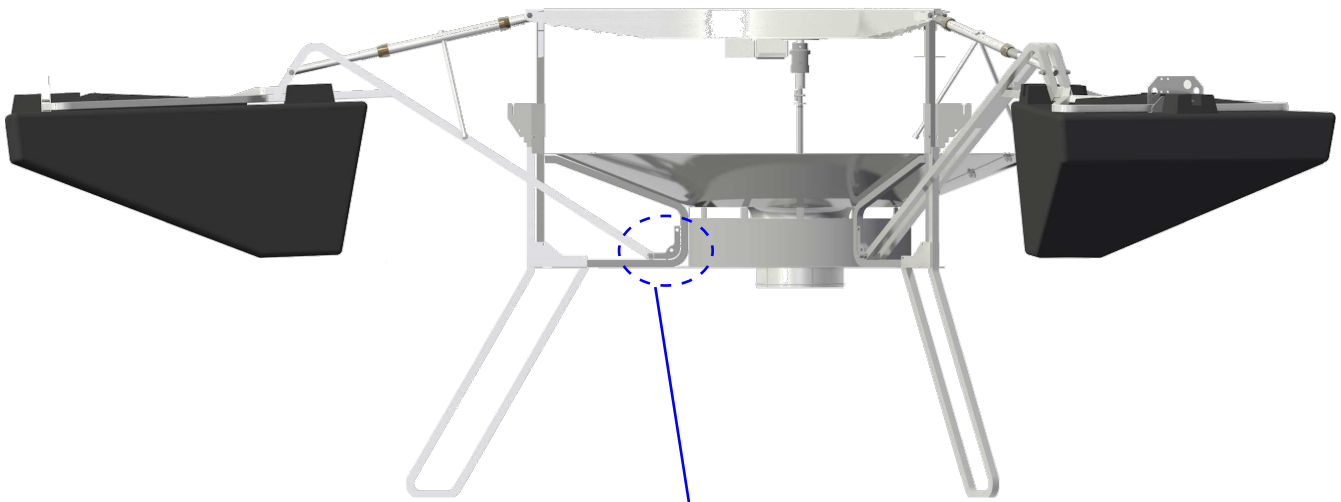

SB10000 WITH 20FT OR MORE HOSE
SB7500 WITH 20FT OR MORE HOSE

SB10000 WITH 15FT (4.5m) OR LESS HOSE
SB 7500 20FT (4.5m) OR LESS HOSE
ALL SB5000
ALL SB2500

ALL POTABLE WATER UNITS
ALL HIGH SALINITY (SALTWATER) APPLICATIONS

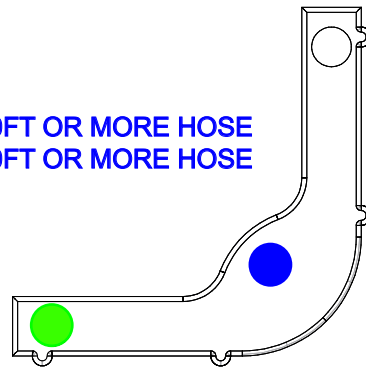

Float Arm Assembly

TOOLS REQUIRED:

(2) 19mm wrench
19mm socket wrench (optional)

STEP 1: Reference the previous page to select which float arm connection hole is required for your machine.

IMPORTANT: Be sure to use the proper hole to avoid a prolonged installation.

STEP 2: Locate the 3 float arm assemblies. Have the M12 x 90mm long bolts and M12 nylok nuts easily accessible near the core unit assembly.

STEP 3: Take the float arm and slip the narrow end with Float Arm Stems around the core unit leg. Align the holes through the Float Arm Stems with the correct float arm connection hole determined from Step 1.

STEP 4: Once aligned slide the M12 X 90mm bolt through all holes. Tighten a M12 nylok nut onto the bolt until there is little play or space between the bolted components. Use a two 19mm wrenches to tighten nut.

STEP 5: Repeat steps 2 and 3 for the other 2 float arms.

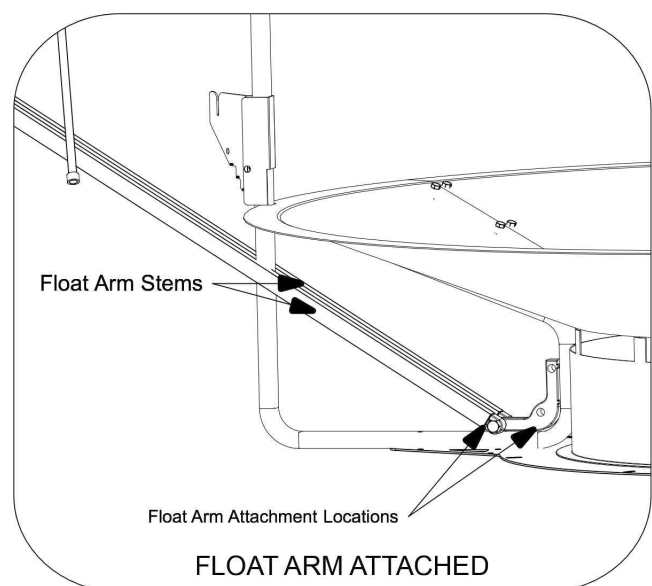
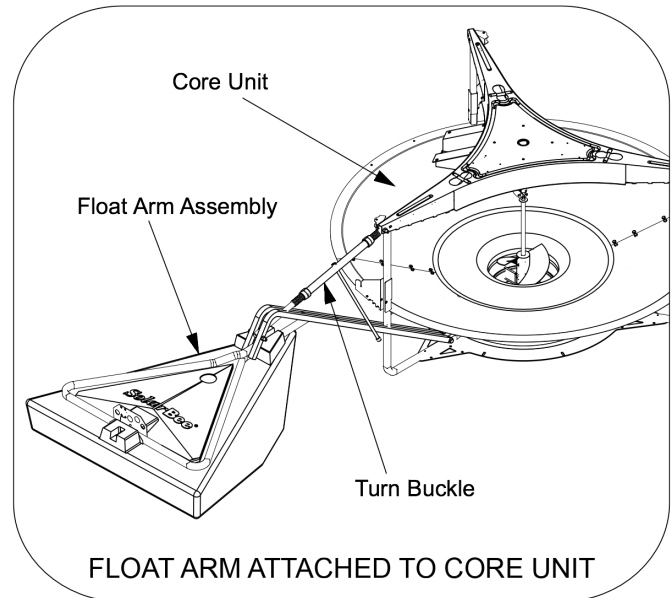

Turnbuckle Assembly

••• IMPORTANT •••

Hold the center of the turnbuckle assembly and turn both ends all the way into the center. Skipping this step will cause decreased extension of turnbuckle and more time to install may be required.

NO TOOLS REQUIRED:

STEP 1: Locate the three turnbuckles, M12 90mm Bolts, M12 55mm Bolts, and Nylok Nuts.

STEP 2: Notice that the turnbuckle assembly has an end with a smooth shaft and the other end with threaded shaft.

STEP 3: Take the threaded shaft end of the turnbuckle assembly and slip it into the TriFrame of the core unit assembly. Align the holes and slide the M12 55mm Bolt into position and tighten the Nylok nut.

STEP 4: Once the upper part of the turnbuckle assembly is in place, take the opposite end of the turnbuckle and slide it into the float arm assembly as shown in picture.

STEP 5: Align the hole through the shaft with the float arm assembly holes and slide the M12 90mm Bolt and tighten the Nylok nut.

STEP 6: Repeat steps 2 through 5 for each turnbuckle assembly.

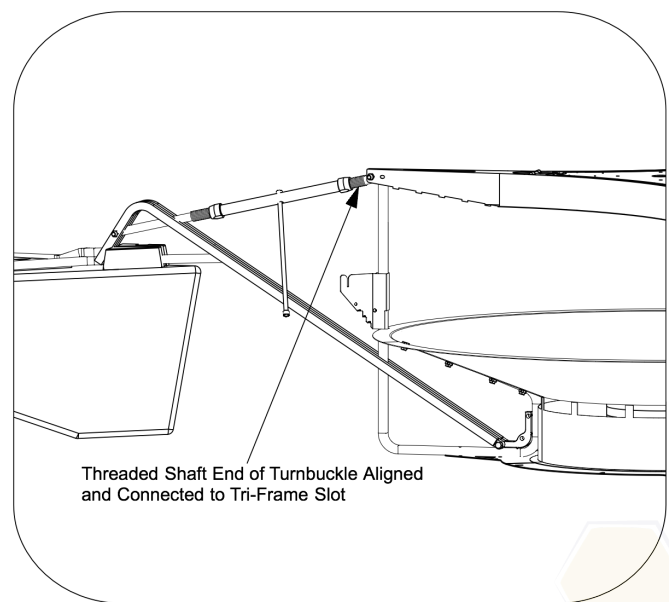
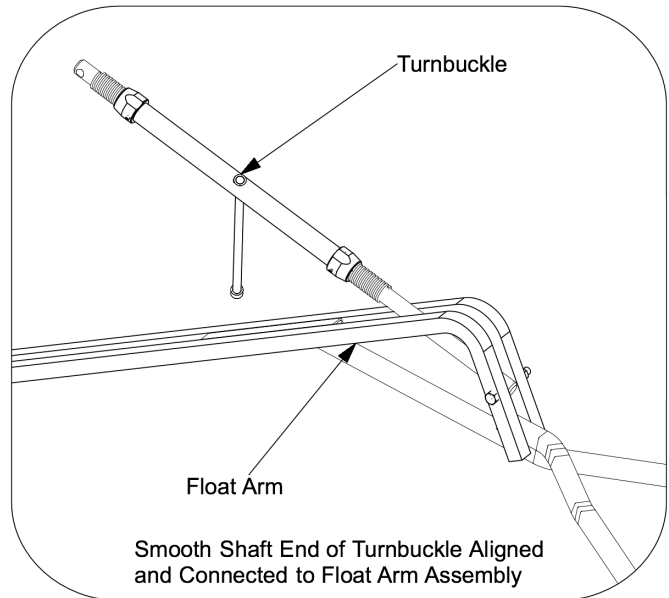

Chain Bracket Assembly

TOOLS REQUIRED:

- (2) 13mm wrench
- 13mm socket wrench (optional)

STEP 1: Locate the 3 chain brackets and the M8 X 45mm long bolts and M8 nylok nuts (3 sets needed).

STEP 2: Notice that along the perimeter of the dish on the core unit assembly, there are three locations where square tubing extends above the dish. Each of the 3 chain brackets will be attached to each of the three square tubing just above the dish.

STEP 3: Place one of the chain brackets over the square tubing with the wider side facing up and the opening facing outward.

STEP 4: Once the chain bracket is slid around the square tubing, insert the M8 x 45mm bolt through the outer holes in the chain bracket. Apply anti-seize to the threads of the bolt. Tighten the M8 nylok nut on the bolt to keep the chain bracket in place using two 13mm wrenches.

STEP 5: Repeat steps 3 and 4 for the other 2 chain brackets.



Applying Anti-Seize
To The Bolts

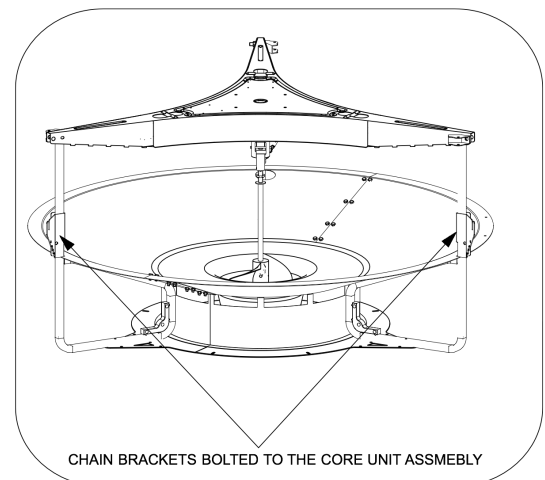
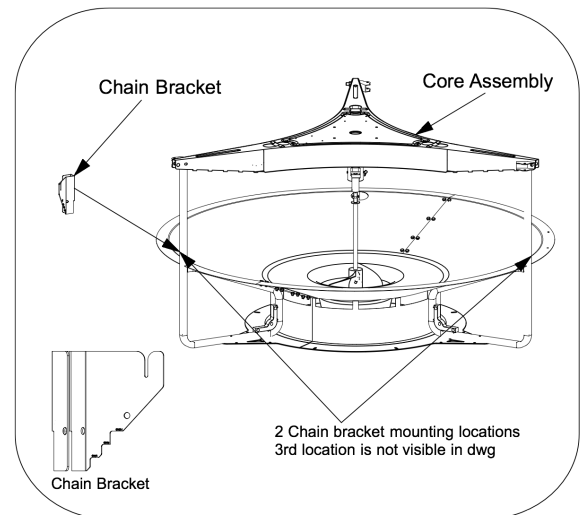
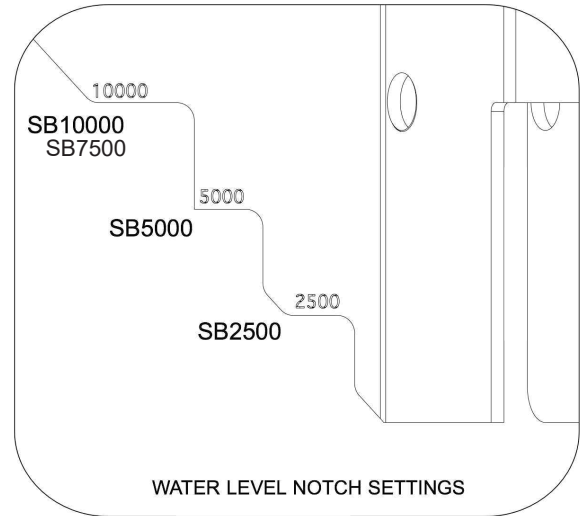

Leg Extension Assembly (IF APPLICABLE)

NO TOOLS REQUIRED:

STEP 1: Tilt or hoist the core unit assembly off the ground. Now the leg extensions can be attached.

STEP 2: Slide the leg extension around the three legs of the Machine core unit assembly and above the bottom flange ring.

STEP 3: Slide the leg extension up snug against the leg to allow two pins to be inserted through the holes of the leg extension.

STEP 4: Fasten the leg extension to the Core unit assembly using a set of two 5/16 inch x 2 inch (8mm x 51mm) clevis pins.

STEP 5: Secure both pins using two hair pins.

STEP 6: Repeat steps 2 through 5 for each leg extension.

NOTE: Once the leg extensions are attached and secure, the leg extensions act as a tri-pod in which the Machine can rest on.



Sliding Leg Extension Around Bottom Leg Of Machine Core Unit

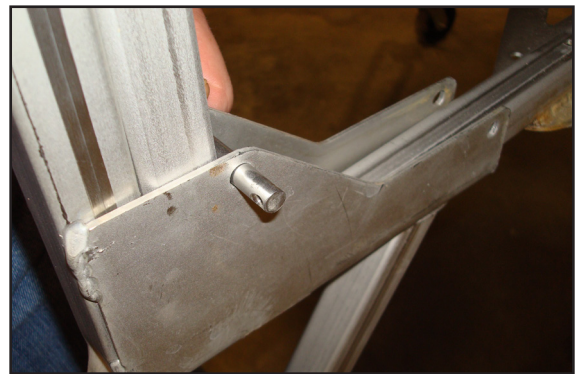

Attaching Leg Extension With a Clevis Pin.

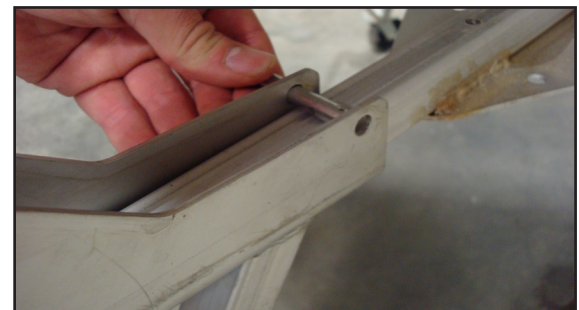

Securing Clevis Pins



Secured with Hair pins

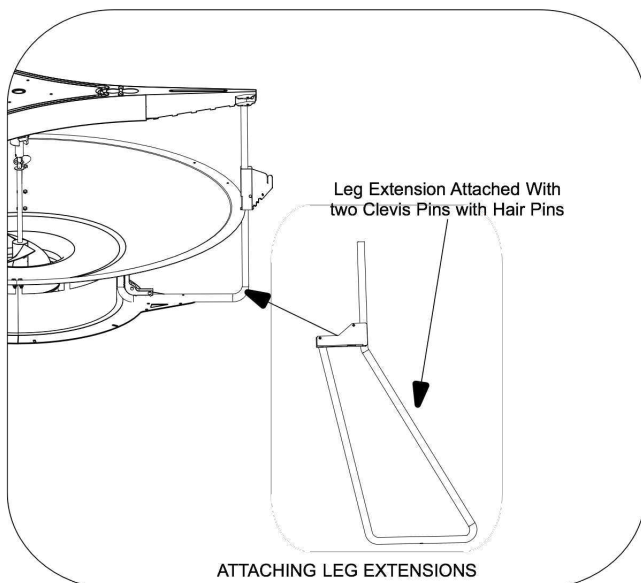

Intake Marker Chain Assembly

TOOLS REQUIRED:

Pliers

STEP 1: Locate the three marker chain sets. These will provide the means to lowering and raising the intake plate level.

STEP 2: The marker chain has numbered indicators represent the depth of the intake plate when that numbered indicator is at water level. For this reason, when attaching the marker chain, the numbers should start highest value at the top and the lowest value at the bottom. The numbers are indicated in feet.

STEP 3: Locate the very lastlink in the chain end having the highest numbered indicator. Use a quick link to attach the link to the small hole located on the chain bracket. Tighten the quick link using a pliers.

STEP 4: Find the last link on the end having the lowest numbered indicator. This link should attach to the welded link located directly below the chain bracket on the hose flange connected to the intake plate. Use a quick link to make this attachment. Tighten the quick link using a pliers.

STEP 5: Once marker chain is connected to the chain bracket and hose flange, pull the chain tight from the nose flange and slide it into the chain slot on the chain bracket.

STEP 6: Repeat steps 2 through 5 for each marker chain.

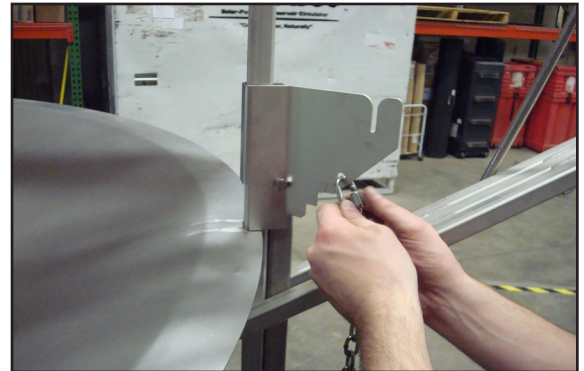

Quick Link connecting end of chain to small chain bracket hole.



Weld link on hose flange connecting opposite end of chain to hose flange.



Marker chain slipped into chain bracket slot.

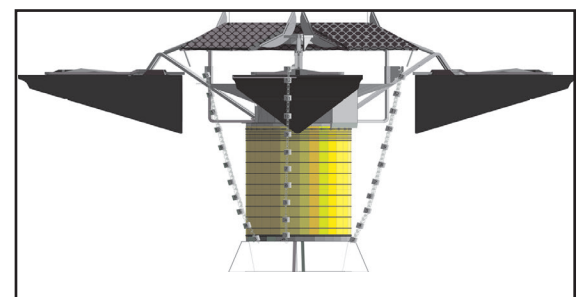

Machine equipped with 3 marker chains.

Maintenance

Maintenance and Field Adjustment

SB / GF Series Large Frame Mixers

The performance of the Mixer has proven to increase tremendously when its operator understands the operation of the machine and knows how to carry out field adjustment procedures.

In most applications, it is strongly encouraged that the operator have a boat to perform routine checkups and field adjustment procedures on the Machine. A large, expensive boat isn't necessary. Our field teams use 12 ft (3.65m) Jon boats that work fine for almost all applications.

It is extremely important that safety comes first every time the Machine is inspected or having maintenance procedures performed. It is strongly encouraged that anyone working on or near the machine follow these rules:



⚠️ Wear a personal floatation device

⚠️ Stay focused and alert

⚠️ Turn the Machine off before working on it

⚠️ Stay clear of parts while they are moving

To turn the Machine motor off, turn the On / Off switch to the off position. To completely power down the digital controller, remove all power sources in the proper sequence.



SAFETY FIRST

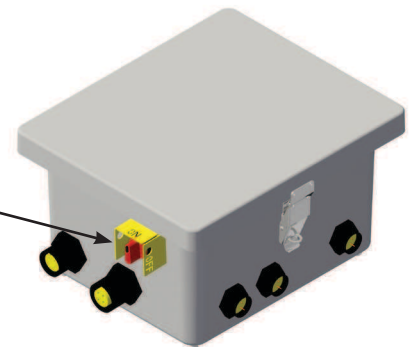
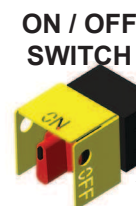

**DIGITAL
CONTROLLER**

Maintenance

Large Frame Rigging Points

SB/GF Series Large Frame Mixers

When deploying a Machine into the reservoir, it may need to be suspended. If suspending the Machine, it must be suspended from all three rigging points to ensure the support of the weight of the Machine and to keep the Machine balanced once suspended. A crane or hoist is often needed in order to suspend the Machine for deployment into the reservoir.

TOOLS REQUIRED:

Crane or Hoist (if necessary)

Boat

STEP 1: Adjust all three turnbuckles to their full extension. This will raise the entire Machine to its maximum height and aid in towing.

STEP 2: Using a three point rigging system, connect to all three rigging points of the Machine. Hoist the Machine by the three rigging points and slowly lower into the reservoir.

STEP 3: Tie as much of the hose up as possible. This will reduce some drag when towing the Machine to its position in the reservoir.

STEP 4: Towing the Machine can be done one of two ways. The first way is to hook a chain, or towing line, around one of the float arms and pull the Machine with a boat. A second option, and in most cases is the best option, is to push the Machine using the front of the boat.

IMPORTANT: DO NOT EXCEED 5 MPH (8KM/HR) WHEN TOWING OR PUSHING A MACHINE.

STEP 5: Once in position, lower the hose into the water. If the hose and strainer are not completely submerged, push them both down until the air trapped inside is released. Once the air is released, the hose will lower down into place.

MODEL MAY VARY



Rigging Points



CAUTION: DO NOT REMOVE ANY FLOAT ASSEMBLY PINS OR BOLTS WHILE THE MACHINE IS FLOATING IN THE WATER! THE MACHINE MUST BE RESTING ON THE GROUND OR SAFELY SUPPORTED TO RELIEVE THE FORCES ON THE FLOAT ASSEMBLY STRUCTURES PRIOR TO DISASSEMBLY! FAILURE TO FOLLOW THIS WARNING COULD LEAD TO SINKING THE MACHINE, OR CAUSE SERIOUS INJURY!

Maintenance

Large Frame Dish Levels

SB / GF Series Large Frame Mixers

Distribution Dish Level Setting

The machine distributor dish depth in the water is a key factor in maintaining the near-laminar flow of water coming off the machine.

The distribution dish level setting is measured from the top lip of the dish up to the water surface. For the Large Frame machine, set the depth level according to the following table:

Model	Depth - Inch	Depth - cm
2500	3/4 - 1	2.0 - 2.5
5000	1 - 1 1/2	2.5 - 3.8
7500	2.0 - 2 1/2	5.1 - 6.4
10000	2.0 - 2 1/2	5.1 - 6.4

Distribution Dish Level Adjustment

TOOLS RECOMMENDED:

Tape Measure

STEP 1: If machine is not on, turn the On/Off switch to the On position.

STEP 2: Observe if the dish level is too deep or not deep enough at the three locations where each float arm extends out from the machine. This can be done using a tape measure, by approximating the height of a nickel, or locating the notch on each chain bracket for machines having a hose. If using the notch on each chain bracket, the water level should be even with the appropriate notch (see picture).

STEP 3: Set the dish to the correct level in each of the three locations. To raise the dish level, rotate the turnbuckle around (clockwise) so that it is expanding. To lower the dish level, rotate the turnbuckle around (counter-clockwise) so that it is compressing.

STEP 4: Double check dish level at all three locations and fine tune as necessary.

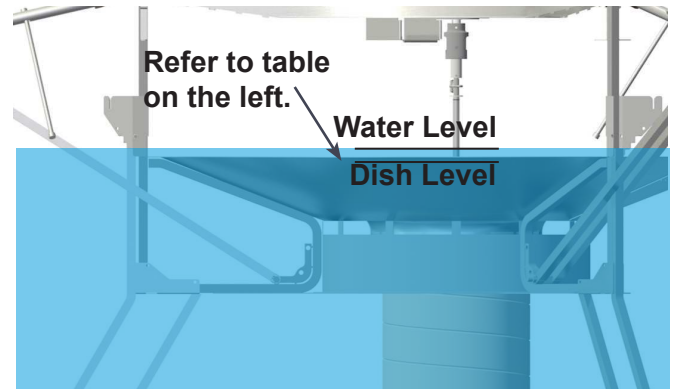

Distance Between Distributor Dish And Water Level

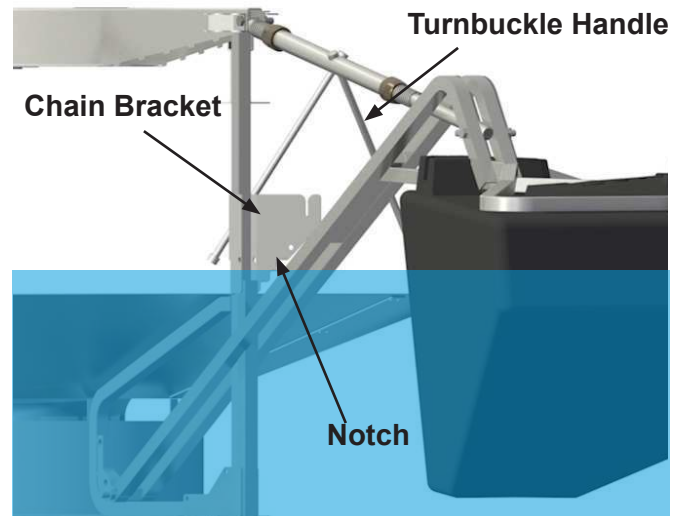

Water Level Even With Notch On Chain Bracket

WATER LEVEL NOTCH SETTING FOR:

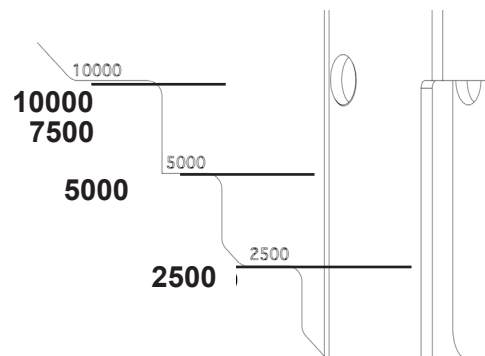

Dish Depths For Different Models of machines

Maintenance

RPM Check

SB/GF Series

Impeller Rotational Speed Check

During clear skies and good sunlight weather conditions, the drive system of the unit should operate:

- 1) At a rotational speed between 55 and 85 revolutions per minute (rpm).
- 2) In a clockwise direction when looking down at the impeller.

Checking Rotational Speed

TOOLS RECOMMENDED:

Watch or Stopwatch

STEP 1: Locate the flag indicator on the impeller shaft.

STEP 2: Start the stopwatch or mark a starting point on the watch. Immediately begin counting each full revolution of the flag indicator (starting with "ZERO", "ONE", "TWO", etc) for a time of less than or equal to 1 minute and at least 20 seconds. This step is easier with two people, one counting revolutions and the other keeping track of the time expired.

STEP 3: Quit counting revolutions and immediately observe how much time has expired in seconds.

STEP 4: Use the following equation to calculate rotational speed in rpms:

$$\text{Revolutions Per Minute (RPM)} = \frac{(\# \text{ Revolutions Counted} \times 60)}{\# \text{ Seconds Expired}}$$

MODEL MAY VARY

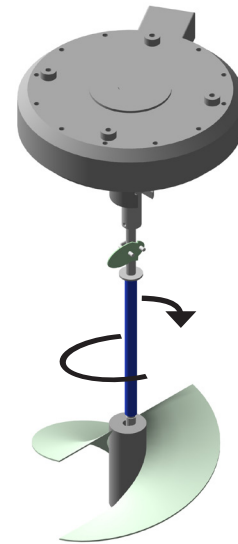

Clockwise Rotation When Looking Down

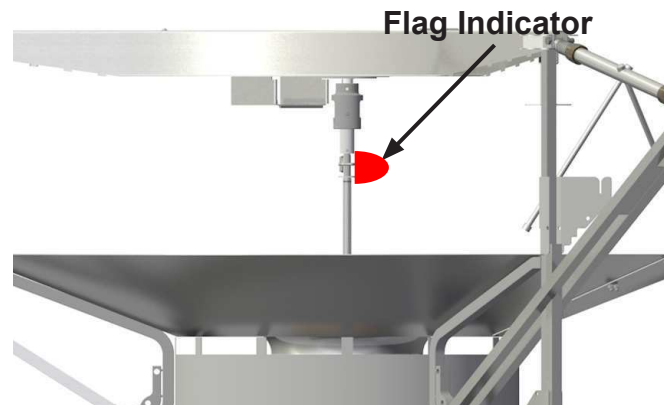

Flag Indicator Section of Impeller Shaft

Example: 30 Revolutions were counted in a time period of 30 seconds.

$$\text{RPM} = (30 \text{ revolutions} \times 60) / (30 \text{ seconds}) = 60$$

Impeller Rotational Speed = 60 RPMs

Maintenance

Impeller Cleaning

SB / GF Series Large Frame Mixers

In some applications, the autoreverse function will not completely eliminate floating debris or aquatic weeds from catching on the impeller blades and shaft. In these applications, impeller cleaning and impeller removal may be necessary.

Impeller Cleaning

TOOLS RECOMMENDED:

- Elbow High Rubber Gloves
- Squeegee
- Garbage Bag



STEP 1: Turn Machine off by placing the On/Off switch into the OFF position.

STEP 2: Open PV module gate for easy access to the impeller. If necessary for better access, use the three turnbuckles to raise machine level.

STEP 3: Using gloves and squeegee, clean off debris or aquatic weeds that are wrapped around impeller blades and shaft. Place the debris into a garbage bag and remove from pond to prevent it from going through Machine again. **Follow all local laws and regulations when disposing of any materials collected.**

STEP 4: Observe if there is buildup below the impeller blades.

If below the impeller is clean, then close the PV module gate, lower dish into the water at proper setting using the turnbuckles, and screw in fuse switch to turn Machine back on.

If there is buildup below the impeller, then see directions for impeller removal on the next page.



Machine With Buildup On Impeller



CAUTION
Moving blade.
Rotating parts and shaft can cause injury.
Keep hands clear while machine is operating.

CAUTION: TURN MACHINE OFF BEFORE WORKING NEAR IMPELLER! WEAR PROTECTIVE GLOVES AND BE CAUTIOUS OF SHARP LEADING EDGES ON IMPELLER BLADES WHILE CLEANING! FAILURE TO FOLLOW THESE WARNINGS COULD LEAD TO INJURY!



Impeller Removal For Buildup Below Impeller

Maintenance

Impeller Assembly Removal

SB / GF Series Large Frame Mixers

Turn Machine Off Before Performing Maintenance

In the case that there is buildup below the impeller that cannot be reached, the rotating assembly can easily be removed.

TOOLS RECOMMENDED:

Elbow High Rubber Gloves
Garbage Bag



STEP 1: With Machine off and PV module gate open, locate the clevis pin going through the upper shaft coupling. Remove the hair pin and pull clevis pin out.

STEP 2: Grab the impeller shaft below the flag indicator, lift up and then outward until lower coupling and shaft are disconnected from upper coupling and brushless motor.

STEP 3: Observe and clean any debris located on the bottom of the impeller.

STEP 4: Observe and clean any debris located down in the dish where the impeller rests. Place the debris into a garbage bag and remove from pond to prevent it from going through Machine again. Follow all local laws and regulations when disposing of any materials collected.

STEP 5: Once clean, place impeller assembly back in place (Slide lower coupling into upper coupling and allow to drop down into place). Be sure bottom of impeller shaft fits into the bushing in the dish and that the coupling sleeve is in place inside the shaft coupling assembly.

STEP 6: Place clevis pin back through upper shaft coupling and secure with hair pin.

STEP 7: Close PV module gate and turn Machine back on.

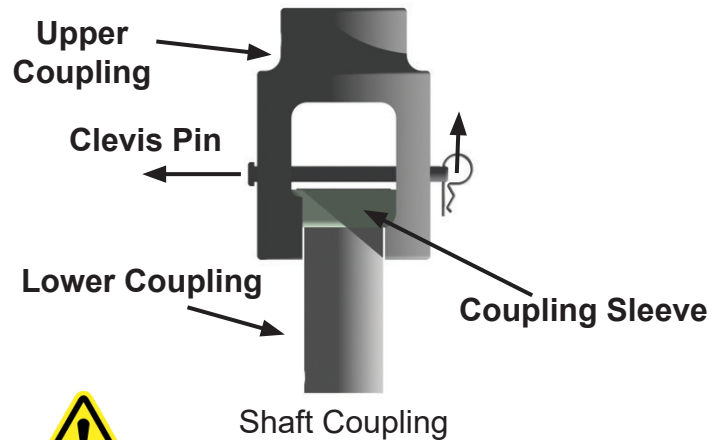

CAUTION: TURN MACHINE OFF BEFORE WORKING NEAR IMPELLER! WEAR PROTECTIVE GLOVES AND BE CAUTIOUS OF SHARP LEADING EDGES ON IMPELLER BLADES WHILE CLEANING! FAILURE TO FOLLOW THESE WARNINGS COULD LEAD TO INJURY!

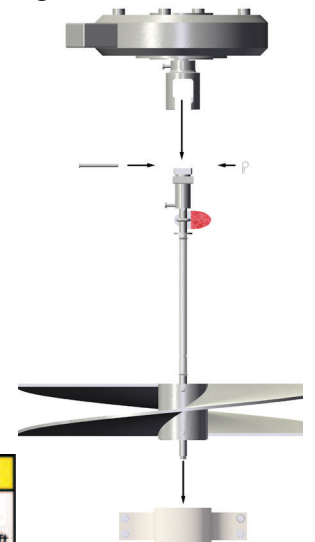

Impeller Assembly Removal Motion



CAUTION
Moving blade.
Rotating parts and shaft can cause injury.
Keep hands clear while machine is operating.

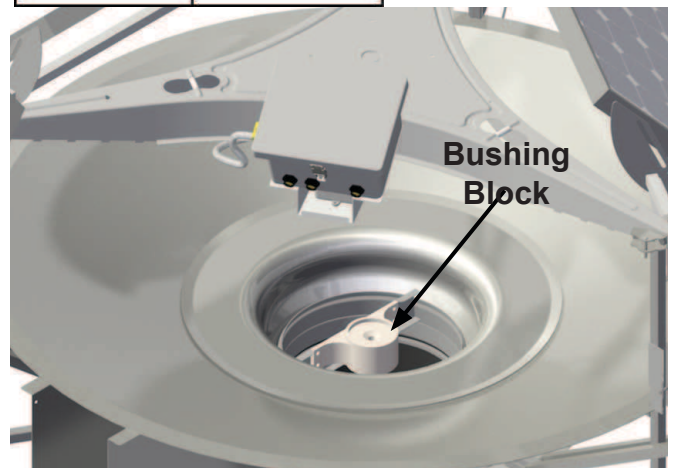

Impeller Assembly Removed

Maintenance

PV Module Cleaning

SB Series Mixers

The solar panels are the SolarBee's primary source of energy, so it is important that they be kept clean. Over time, dust collects on the PV modules or birds are not kept completely off by the bird deterrent resulting in the panel's effective surface area decreasing.

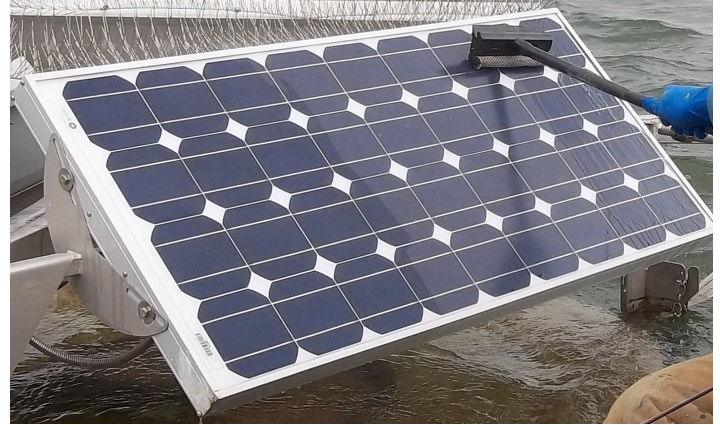

(If Equipped the following applies)

The SolarBee controller and solar panel(s) are generally located on the roof of the tank or reservoir. If your tank is ground storage standpipe, hydro-pillar, pedosphere, or other style elevated tank, please follow the necessary OSHA regulations in regards to Fall Protection, Rescue, etc.



TOOLS RECOMMENDED:

Squeegee
Glass Cleaner
Paper Towel or Wash Cloth

STEP 1: Rinse panel face off with water.

STEP 2: Use squeegee, towel, or wash cloth to clean surface of panel.

STEP 3: Remove any streaks or films using glass cleaner and paper towel/wash cloth.

STEP 4: Repeat Steps 1 through 3 for each solar panel.



Maintenance

Solar Panel Angle Adjustment

SB Series Large Frame Mixers

The SolarBee technology includes tilting PV modules to allow for optimal solar collection for different geographical regions and changing sun position during the seasons.

Use 35 Degree (Flattest Position):

Where - Locations south of 40 degree latitude.
When - During fall, summer, and spring or year round if no adjustment is preferred.

OR

Where - Locations north of 40 degree latitude.
When - During summer only.

Use 45 Degree (Middle Position):

Where - Locations north of 40 degree latitude (Especially Great Lakes Region and Canada).
When - During spring and fall or year round if no adjustment is preferred.

OR

Where - Locations south of 40 degree latitude.
When - During winter

Use 55 Degree (Steepest Position):

Where - Locations north of 40 degree latitude.
When - During winter season or periods of abundant snow (The steep angle will help prevent snow from building up on the panels).

TOOLS RECOMMENDED:

Two 1/2" or 13mm wrenches

STEP 1: Loosen 2 bolts on each end of the PV module using 1/2" or 13mm wrenches as shown in the figure below.

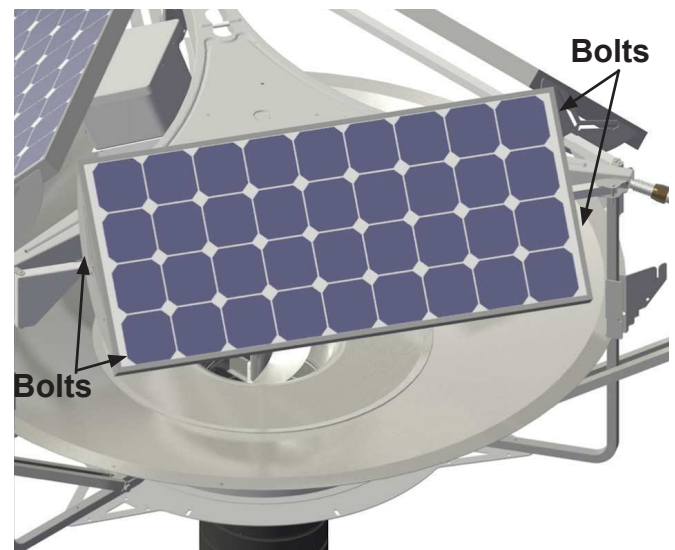

STEP 2: Firmly grip the PV module and slide it up or down the tracks until it is in the desired position. For each of the three recommended angle settings listed, there is a slot in the top tracks at both ends that the top bolt will drop into.

STEP 3: Once the PV module is in the desired position, tighten all four bolts.

STEP 4: Repeat steps 1 through 3 for other two solar panels

Maintenance

Hose Strainer Depth and Cleaning

SB / GF Series Mixers

Hose Strainer Depth Setting

The hose strainer depth is either set by a buoyant float inside the strainer or chained up at a specific depth. If the hose strainer is not tied up using the attached chain, the water will enter the hose approximately 1.5 to 2 feet (0.45m to 0.6m) above solid bottom of the pond. In some cases, the hose strainer depth will need to be chained up to a higher level in the water.

Hose Strainer Depth Adjustment

TOOLS RECOMMENDED:

Tape Measure

STEP 1: Determine the new hose strainer setting after consulting with a Ixom Watercare, Inc. service team member.

STEP 2: Use the tape measure to determine how deep the pond at the Mixer.

STEP 3: Locate the white float ball that is on one of the floats. This float ball marks the chain that is attached to the submerged hose strainer.

STEP 4: If the strainer is suspended by the buoyant float and not tied up by the chain, the strainer is approximately 1.5 to 2 feet (0.45m to 0.6m) above the solid bottom. If the strainer is tied up, let it loose so it is suspended by the buoyant float. Use the depth measurement made in Step 2 to determine how deep the strainer is.

STEP 5: Lift the chain up until the strainer is at the desired setting and tie off to the float plate.

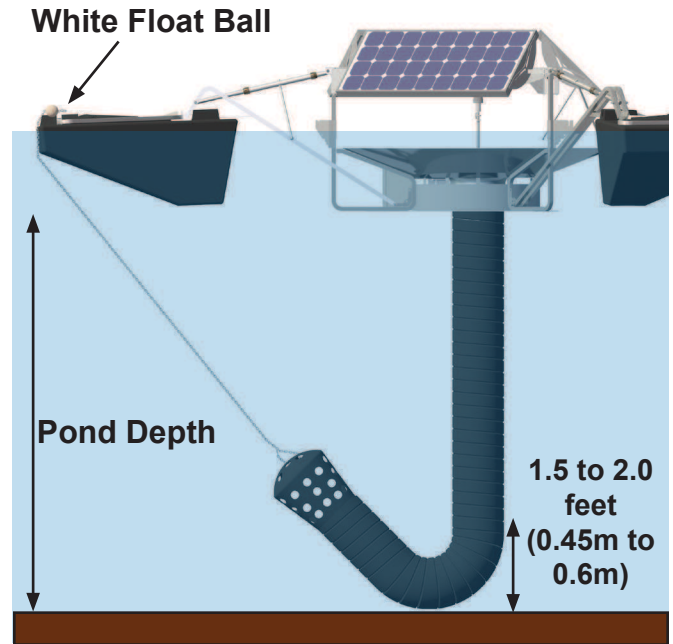

Strainer Free Floating, Not Tied Up

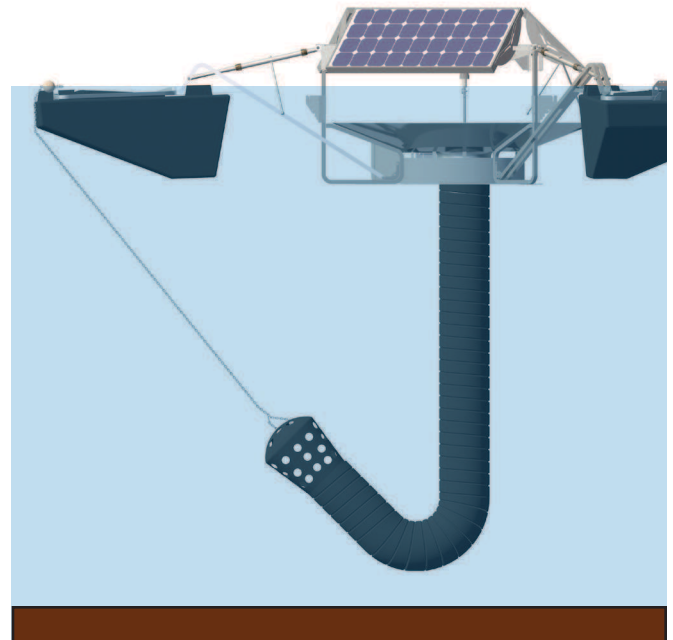

Strainer Chained Up, Not Free Floating

Maintenance

Hose Strainer Depth and Cleaning

SB / GF Series Mixers

Hose Strainer Cleaning

In some applications where floating debris or garbage is present in the pond, the hose strainer may become plugged. In these applications, the strainer will need to be cleaned on a regular basis to maintain optimal performance of the Mixer.

TOOLS RECOMMENDED:

- Rubber Gloves
- Garbage Bag



Partially Plugged Strainer

STEP 1: Turn Mixer off by placing the On/Off switch into the OFF position.

STEP 2: Locate the white float ball on one of the floats. The float white float ball marks the chain that attaches to the submerged strainer.

STEP 3: Using rubber gloves, pull up on the chain until the strainer is above the water. If there is debris or garbage on the strainer, remove it, place it in a garbage bag, and take it out of the pond to prevent it from hanging up on the strainer again. **Follow all local laws and regulations when disposing of any materials collected.**

STEP 4: Once all the garbage and debris are removed, let the strainer sink back into place. It is a good idea to setup your own schedule of routinely checking the strainer for plugging based on the amount of garbage and debris you find.

STEP 5: Turn Mixer back on.

ON / OFF SWITCH

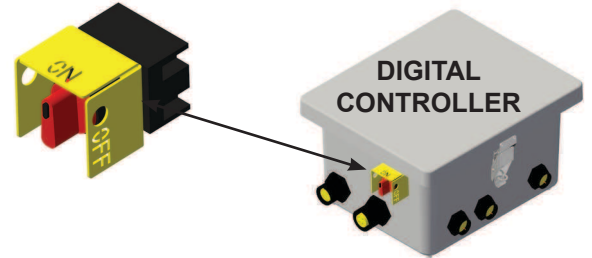

White Float Ball

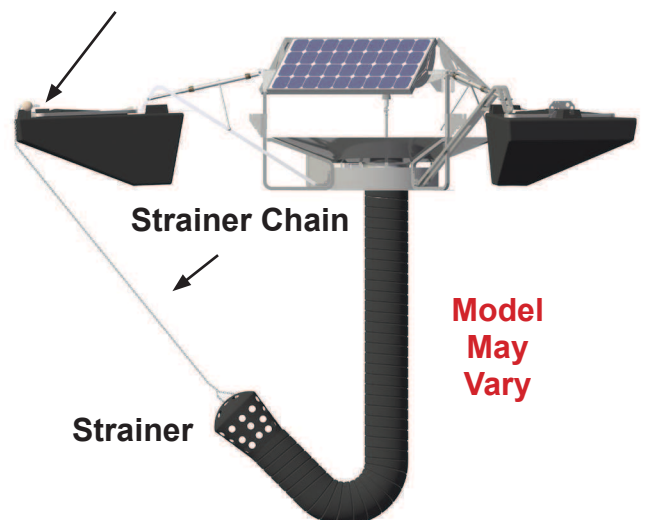

Strainer Chain

Strainer

Model May Vary

Strainer Hose And Chain

Maintenance

Battery Replacement

SB Series Mixers Floating

The SolarBee contains an on-board battery that will require infrequent replacement. Between 2 and 3 replacements are expected over the course of the machine life.

TOOLS RECOMMENDED:

13 mm wrench
13 mm socket wrench

STEP 1: Extend all 3 turnbuckles out all the way to raise the machine out of the water enough to expose the entire battery compartment.

STEP 2: Open the PV gate over the controller and perform a complete power down procedure on the SolarBee, refer to the proper Power Down Procedure in the Electrical Section.

STEP 3: With the SolarBee off, locate the battery compartment below the SolarBee distribution dish.

STEP 4: Using the 13 mm wrenches, loosen and remove the upper bolt and locking nut. This will allow the battery lid to be opened up. (If possible, allow the battery lid to lay down on a stable part of the boat)

STEP 5: First fish through the battery lead from the back of the battery compartment, then pull the battery out into boat.

STEP 6: Install new battery into position and fish battery lead through the back of the battery compartment.

STEP 7: Close the battery lid and tighten bolt and nut to secure in place.

STEP 8: Completely power up SolarBee, refer to proper Power Up Procedure in the Electrical Section. Close panel gate, and reset dish depth.

**** Failure to follow these steps could result in component damage. ****

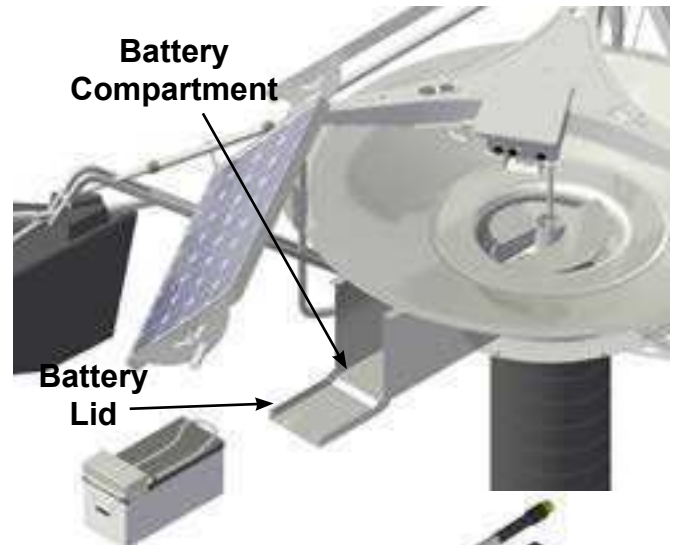

IMPORTANT NOTE:
The battery weighs approximately 140 lbs and may require two people to handle.



Battery Disposal:
Be sure to follow local law and regulations when disposing of the used up battery!



Battery Lid Down, Battery Lead Out

Maintenance

Repositioning the SolarBee

SB Series Mixers

Repositioning The SolarBee

Under some circumstances, the SolarBee unit may need to be moved or placed back into its original location if severe weather hits.

Repositioning Mooring Block Systems

TOOLS RECOMMENDED:

Motor Powered Boat



STEP 1: Locate the white float ball that marks the strainer chain. Pull the strainer chain up and tie off on the float plate, so when moving SolarBee strainer and hose don't hit the bottom.

STEP 2: Locate the anchor chain connection point to the SolarBee.

STEP 3: Begin pulling the anchor chain slack until your boat is directly above the first mooring block. Pull up on the anchor chain and pop the first mooring block loose. Once the first mooring block is popped free, pull up more anchor chain and pop the second mooring block.

STEP 4: Once both mooring blocks are loose from the bottom, pull them up so they are off the bottom and tie them off the boat. The mooring blocks don't need to be pulled completely out of the water, just high enough so they won't hit the bottom when you are moving.

STEP 5: Pull the SolarBee with the suspended mooring blocks to the desired location using the boat. Untie the anchor chain from the boat letting the mooring blocks fall to the bottom. Stay clear of sinking anchor chain!

STEP 6: Lower the strainer back down.

Anchor Chain Connection

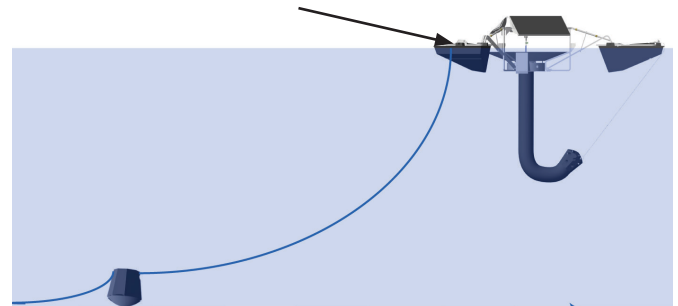

SolarBee Anchored With Mooring Block System



Mooring Blocks Suspended, Ready To Move



WARNING
Entanglement Hazard.
Heavily weighted chain.
Keep hands and feet clear while setting the anchors.



WARNING: WHEN SINKING THE MOORING BLOCKS, BE SURE TO STAY CLEAR OF THE SINKING ANCHOR CHAIN! LOWER THE MOORING BLOCKS INTO THE WATER SLOWLY. FAILURE TO DO SO COULD RESULT IN SERIOUS INJURY OR DEATH BY DROWNING!

Maintenance

Winter Conditions

SB Series Mixers

Winter Conditions

In some locations, heavy snowfall and frigid temperatures may be present during the winter season. During these conditions, it is possible that the SolarBee becomes frozen in by ice and snow causing it to stop turning.

The SolarBee is designed to avoid being damaged when it is stalled and as the ice starts to melt it will start back up again.

When the SolarBee is beginning to freeze in or starting to thaw out, the ice around the machine is not stable enough to support weight. Also, in many cases, one cannot recognize that the ice is thin around the machine. For this reason, it is highly recommended that the SolarBee should **NOT** be approached during the period of time it is frozen in.

In some locations there may be public access or recreation such as ice fishing, snowmobile traffic, or other activities on the water body during winter. For these locations, **SolarBee strongly recommends turning the machine off** by late fall (Nov 15th in U.S.) before freeze up. The area around the SolarBee would then freeze in solid as the rest of the lake does, decreasing the chance of a serious accident near the machine.

If these recommendations are not followed, the SolarBee will cause thin ice several meters around the vicinity of the SolarBee creating a very large hazardous area.

When it is desired for the SolarBee to freeze in and the location requires the SolarBee to be turned off in late fall, it is important to verify that the machine is not operating prior to ice formation. Once winter passes and the ice melts away, the machine should be turned back on to get an early spring start.



SolarBee In A Lake That Is Partially Frozen















WARNING: DURING WINTER CONDITIONS WHEN THE SOLARBEE IS FROZEN IN OR PARTIALLY FROZEN IN, THE MACHINE SHOULD NOT BE APPROACHED. THE ICE AND SNOW AROUND THE SOLARBEE SHOULD NOT BE ASSUMED TO SUPPORT WEIGHT. FAILURE TO DO SO CAN RESULT IN SERIOUS INJURY OR DEATH BY DROWNING OR HYPOTHERMIA!!!



SolarBee Completely Froze In

SolarBee/GridBee SD Card

Update Instructions

Insert the SD card into the slot. The solid blue light beside the slot will come on.	 SD CARD INSERTED
Once the correct files have been found, the green light will begin to flash rapidly.	 FILE SEARCH AND DOWNLOAD
When it is time to remove the card, the green and yellow lights will flash rapidly and be alternating. Remove the SD card from the slot.	 DOWNLOAD COMPLETE REMOVE SD CARD
When the card is removed, the red light will flash rapidly. This is the beginning of the self programming with instructions received from the SD card. After the red light is finished, the yellow light will flash rapidly, followed by the green light.	   INITIALIZING PROGRAM
Upon completion the brainboard will restart and perform a system check. Following a successful update the red light blinking once followed by one yellow blink and one green. If you miss this or are unsure, you can repeat the previous steps	   SD CARD UPDATE SUCCESSFUL
If the update was not successful, the red, yellow, and green lights will blink together 10 times. The machine will revert to the default parameters. Insert the card to attempt the update again. If it still fails, contact Customer Service.	   UNSUCCESSFUL SD CARD UPDATE

Please refer to the provided owners manual for normal operation led blink codes.

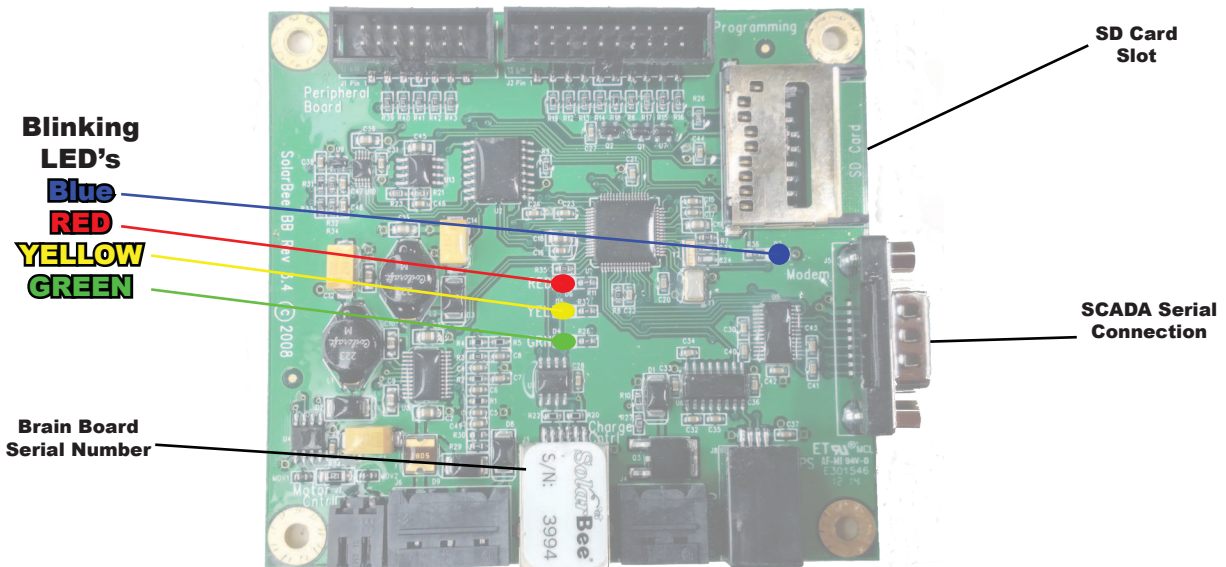

Figure 1: Brainboard

Electrical

Power Down / Power Up Procedure

SB Series

Complete Power Down Procedure

NO TOOLS REQUIRED:

STEP 1: Turn the On/Off switch to Off position.

STEP 2: Unscrew all PV module leads on the front side of the digital controller.

STEP 3: Unscrew the on-shore (grid power) connection on the right face, if applicable.

STEP 4: Disconnect the battery lead on the left face. Now all power is taken away from the electrical system.

Be certain steps 1-4 have been completed before continuing. If this order is not followed, component damage may occur.

STEP 5 & 6: Disconnect the motor controller from the digital controller and from the motor if needed.

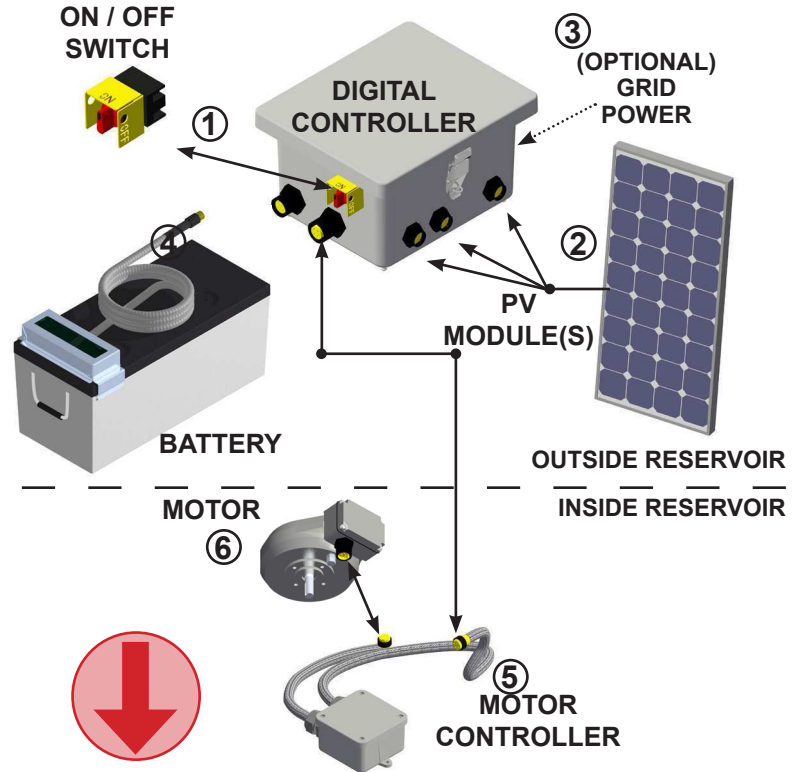

Complete Power Up Procedure

NO TOOLS REQUIRED:

STEP 1 & 2: Connect the motor controller to the motor and to the digital controller.

Be certain steps 1-2 have been completed before continuing. If this order is not followed, component damage may occur.

STEP 3: Now you are able to bring power to boot up the system by plugging in the 4P Male connector of the battery to the left face of the digital controller.

STEP 4: If applicable, connect the on-shore (grid power) 2P male connection to the right side of the digital controller.

STEP 5: Connect all available PV module leads into the front face of the digital controller.

STEP 6: Turn the On/Off switch to On position.

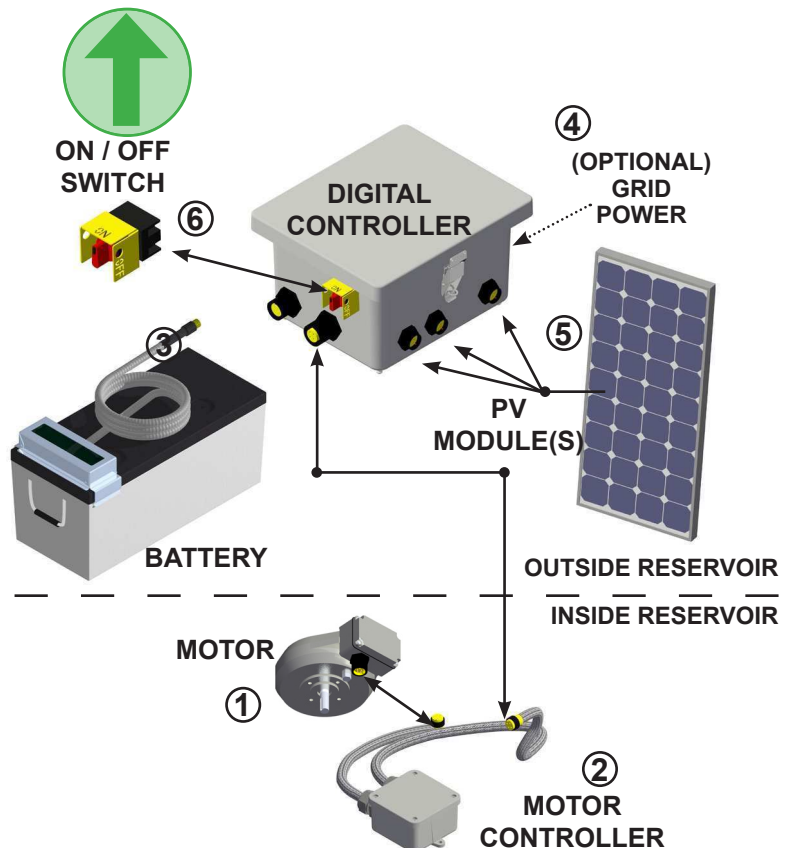

Troubleshooting

Troubleshooting

SB Series

If you find that the SolarBee has quit operating, the following checks can be performed:

Connection Check -

- 1) Locate the digital controller and be sure that each PV module cord is properly connected.
- 2) Check that the battery is properly connected.
- 3) Follow each cord from the electronic controller to its originating component and be sure it is not damaged.

Visual Digital Controller Check - The

SolarBee contains an LED (Light Emitting Diode) blink sequence that indicates the machine operation status. The blinking LEDs are found on the Brain-board located inside the digital controller. A solid green LED is also located on the Zahn board. To observe the LEDs,

- 1) Open the door of the digital controller and locate the laminated LED label on the inside of the door.
- 2) Using the LED label, locate the Brain-board and the Zahn board. Observe and record the blinking LEDs (color and # of blinks in succession) and solid green LED (off or on).
- 3) Using the LED label, match your blink observations to the corresponding indication. Use the information on the next two pages to proceed.

DC Voltage Check -

If a DC voltmeter is available, the battery voltage can be measured off of the brainboard at the 3-pin connection (white, black, and orange leads).

- 1) Using the voltmeter positive lead on the white screw terminal and voltmeter negative lead on the black screw terminal, the voltage can be measured.
- 2) Record the measurement.

SCADA Information - SolarBee operation status information can be transmitted from the machine to a nearby monitoring station by using one of SolarBee's various SCADA kits. Contact Ixom Watercare, Inc. Customer Service for more information.

Ixom Watercare, Inc. is committed to serving our customers. Feel free to contact a SolarBee Customer Service Representative if you experience any problems with your SolarBee. At SolarBee, we will get you technical support, parts, or a service visit to make sure that your SolarBee is back online in short time. (866) 437-8076 or customerservice@ixom.com



SolarBee Installation / Service Crew

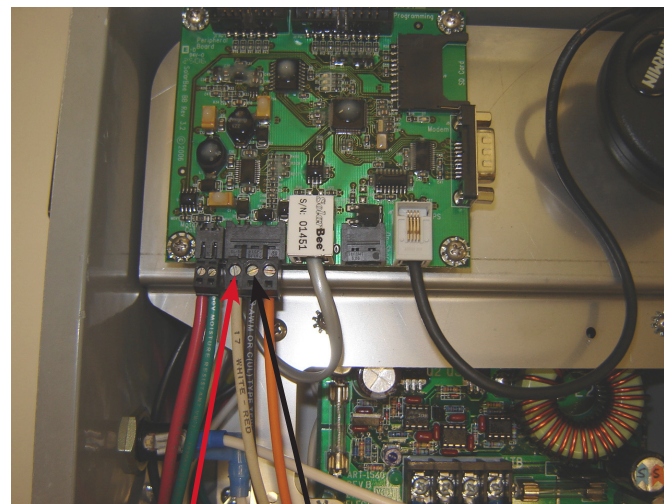

12 VDC+

12 VDC-

Troubleshooting

Troubleshooting

SB Series

Blink Indication Follow-up Procedures

Blinking Green - System healthy, machine should be operating on programmed run schedule. If not operating on programmed run schedule, contact SolarBee Customer Service.

1X Blinking Yellow - High motor current, check the machine for plugging at impeller and/or strainer-intake.

2X Blinking Yellow - Low battery voltage, machine may be operating at reduced speed or temporarily shut down due to cloudy weather period. Re-check machine after sunlight conditions improve.

5X Blinking Yellow - Check GPS connection at Brain-Board (lower right corner). If properly connected and blink code persists, contact SolarBee Customer Service.

1X Blinking Red - Anti-Jam Routine, machine is operating on a jam removal sequence triggered by high current. Check for plugging only after disconnecting power. If power is not removed first, machine may begin to operate

2X Blinking Red - 36 VDC out of range, machine may be shut down due to blown fuse (glass cylindrical) on the Zahn Board. Left side of Zahn board takes a 5 Amp Fuse, Right side of Zahn board takes a 20 Amp Fuse. Disconnect power before changing fuses. Blown fuses may be difficult to observe, so a continuity tester or new fuse should be used to confirm that the problem is not a blown fuse. If your SolarBee has a fuse switch (20 Amp), check that fuse also.

5X Blinking Red - Battery out of range, machine battery is too low. Check and record battery voltage if possible, then contact SolarBee Customer Service.

For all other blink codes, please contact SolarBee Customer Service.

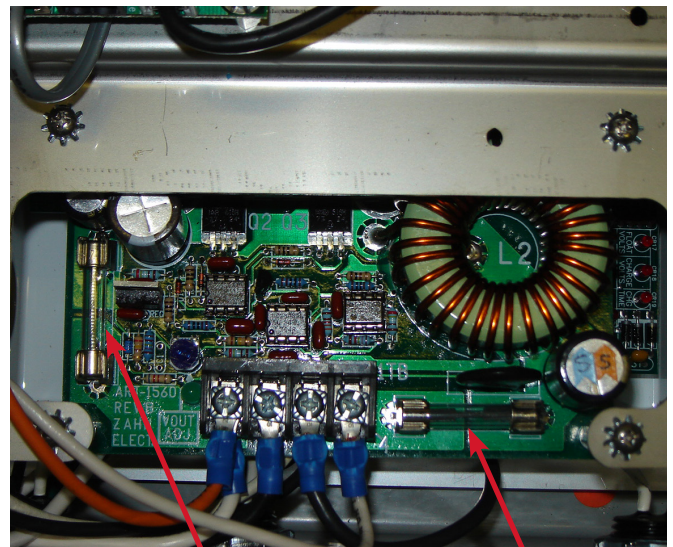
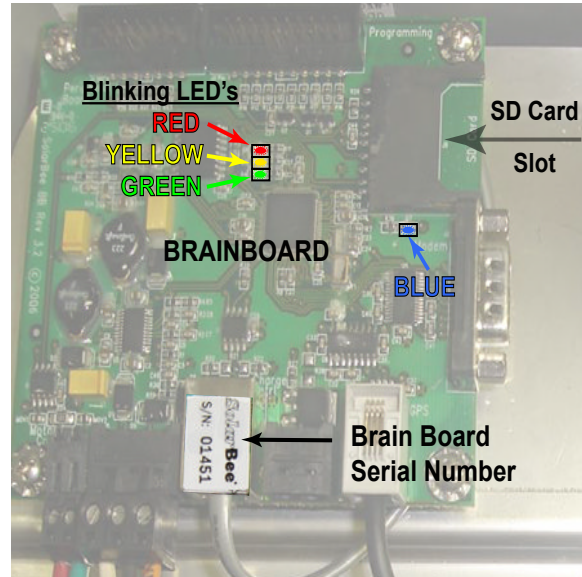

5 Amp Fuse

20 Amp Fuse

ON / OFF SWITCH

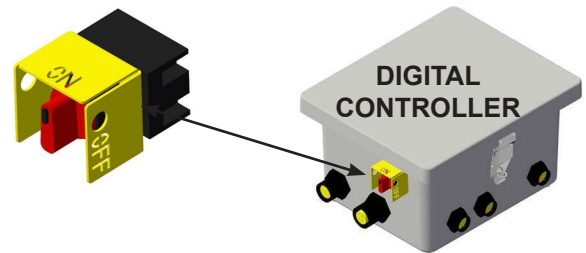

SB Series Status Codes

SB Series: Control Box Lid Label

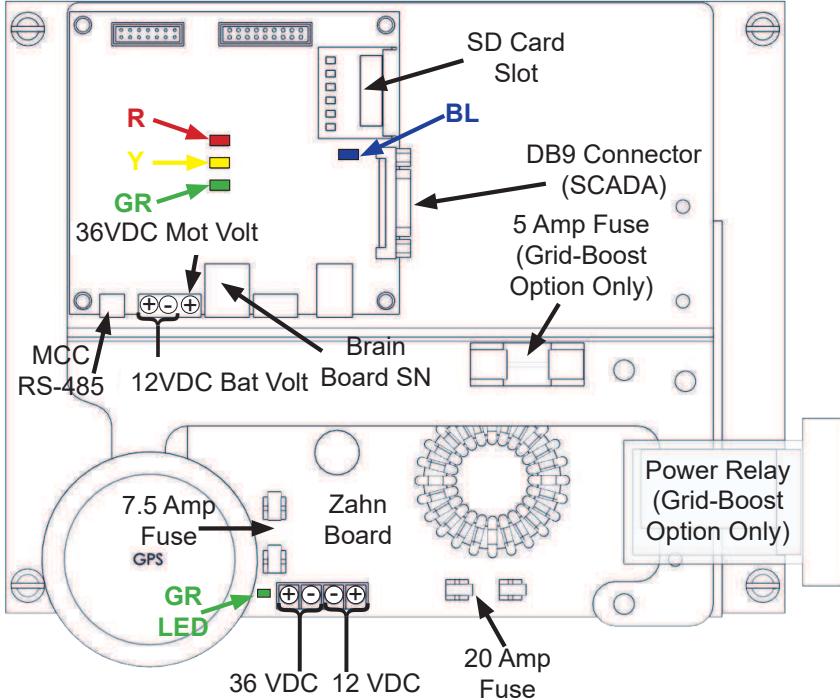

BEHAVIOR	VISUAL	INDICATION
BLINK GR		HEALTHY SYSTEM
SOLID R, Y, GR		HARDWARE ERROR
R, Y, GR OFF		HARDWARE ERROR
SOLID BL		SD CARD INSERTED
1X R, Y, GR		CUSTOM SYSTEM BOOT UP
1X R		ANTI-JAM ROUTINE
2X R		36 VDC OUT OF RANGE
3X R		MOTOR COMM ERROR
4X R		CHARGE COMM ERROR
5X R		BATT OUT OF RANGE
1X Y		HIGH MOTOR CURRENT
2X Y		LOW BATT VOLTAGE
3X Y		TEMP OUT OF RANGE
4X Y		5 VDC OUT OF RANGE
5X Y		GPS COMM ERROR
10X R, Y, GR		INCOMPLETE SD CARD UPDATE
1X Y, GR		GPS SATELLITE LOCK ERROR

Power Up and Power Down Sequence

Power Down	Component	Power Up
1	On/Off Switch	6
2	PV Panels	5
3	Grid Power (Grid-Boost)	4
4	Battery	3
5	Motor Control Cord (MCC)	2
6	Motor	1

Zahn Board Green LED	
On	12 VDC to Zahn
Off	No Power to Zahn

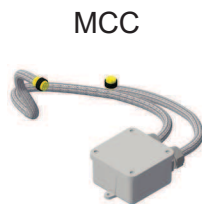
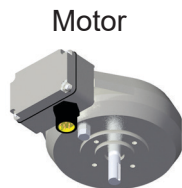

On/Off Switch

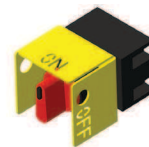

Battery

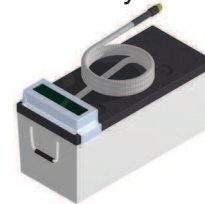

Grid-Boost Option
(36 VDC connection on right side)

MCC

MCC Connection

Battery Connection

PV Panel Connections

PV Panel

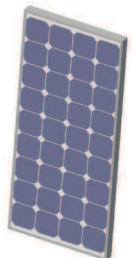

Troubleshooting

Fallback RPM Schedule

For Solar-Powered Floating Mixers

The below design calculations are in regards to the power conservation & continued operation mode of Ixom Watercare, Inc.'s solar-powered mixing control systems.

The SolarBee control system includes a brain board component with pre-programmed algorithms for reducing motor load and continuing operation by incremental speed reduction, thus incrementally reducing motor load and load being drawn from the battery. This feature is automatically enabled when extended low sunlight conditions occur or battery reserve power is reduced. This feature is commonly referred to as Fallback RPM.

Below is the detailed Fallback RPM chart, based on battery voltage and percentage of commanded or scheduled run speed, typically programmed for full speed of 80rpm.

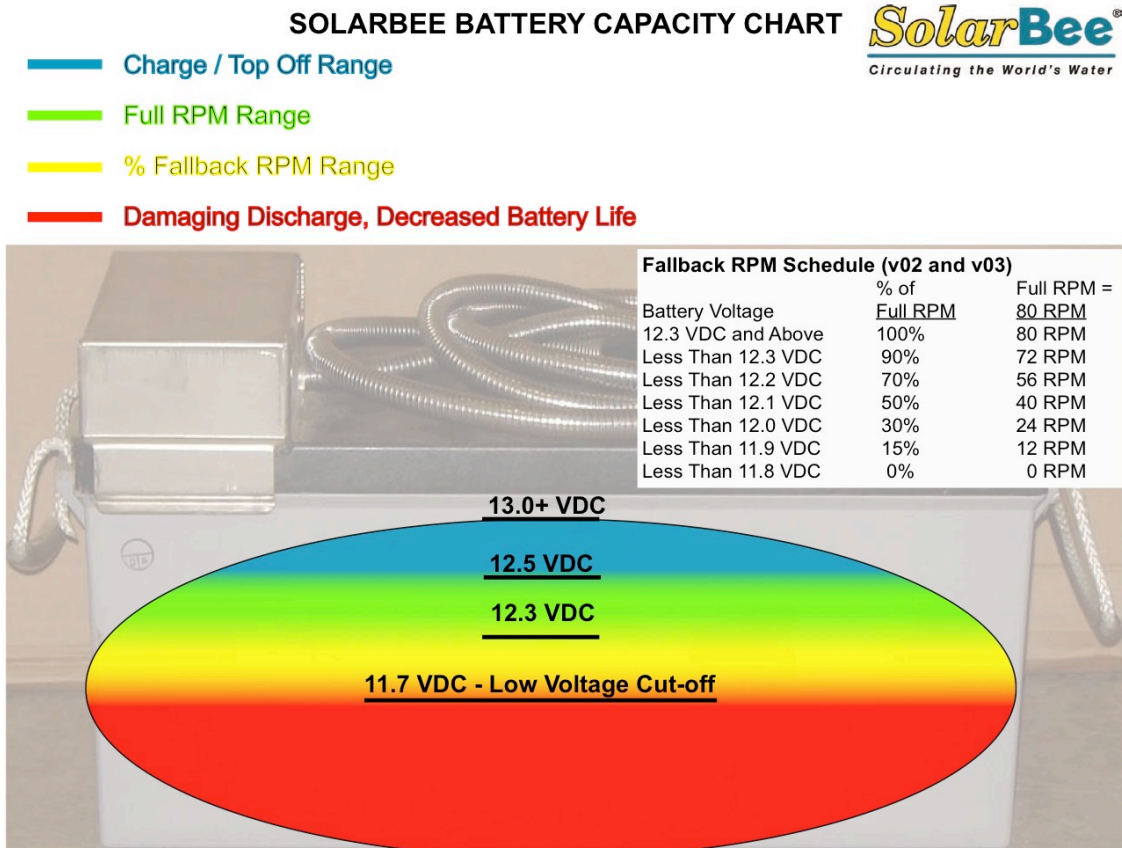

Parts Diagram

SB10000DM Parts Diagram

NO.	PART#	DESCRIPTION
01	PN: 22281100	Impeller Assembly
02	PN: 100428	Core Frame
03	PN: 14283087	Solar Panel Assembly
04	PN: 18260225	Float Arm Assembly
05	PN: 24010100	Float
06	PN: 18265000	Turnbuckle Assembly
07	PN: 14300000	Control Box
08	PN: 14013022	Motor Control Cord
09	PN: 20014500	14" Brushless Motor
10	PN: 14285212	Battery Assembly
11	PN: 26011220	12" x 20' Hose
12	PN: 26128005	Intake Plate
13	PN: 26284012	Intake Strainer

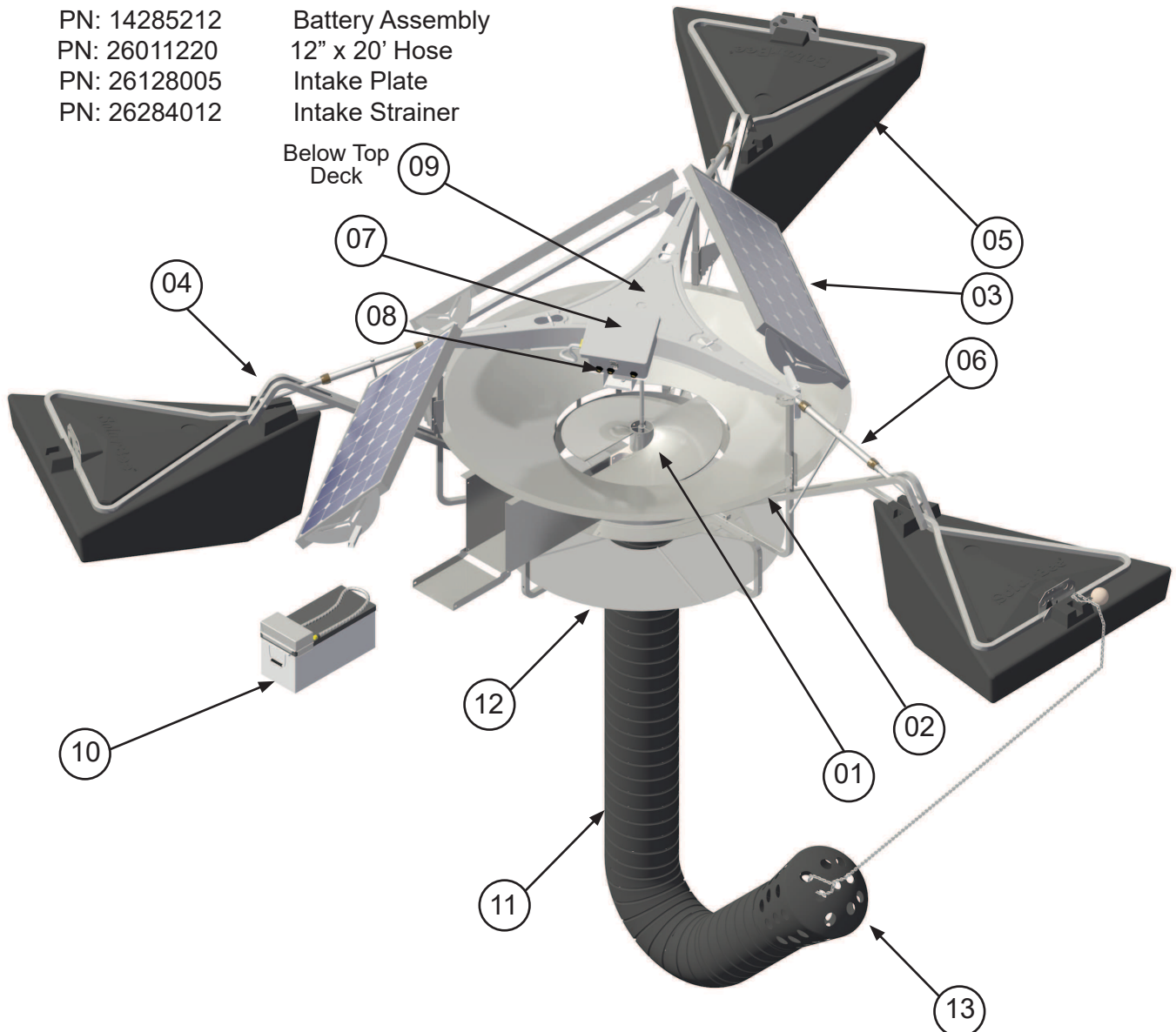

Dimension Drawing

SB10000DM

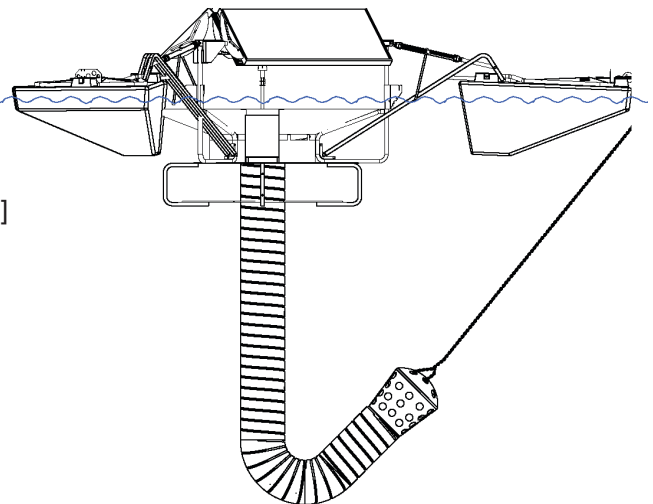
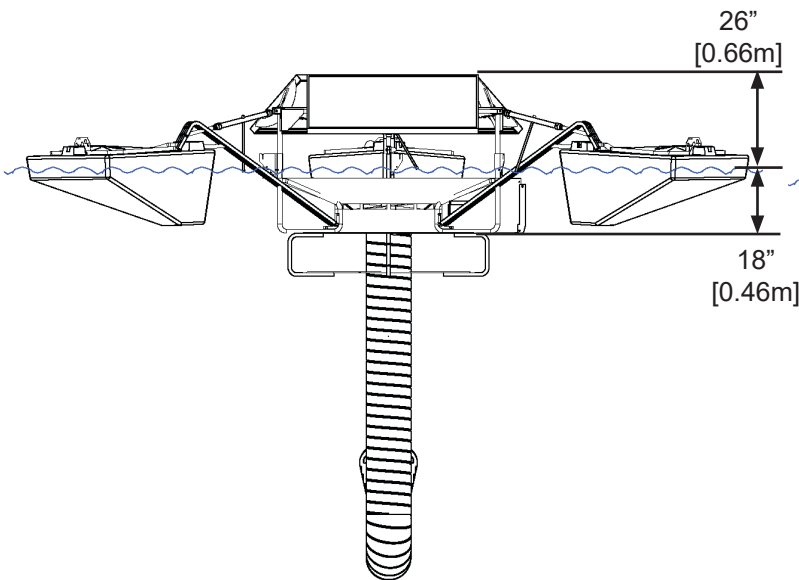
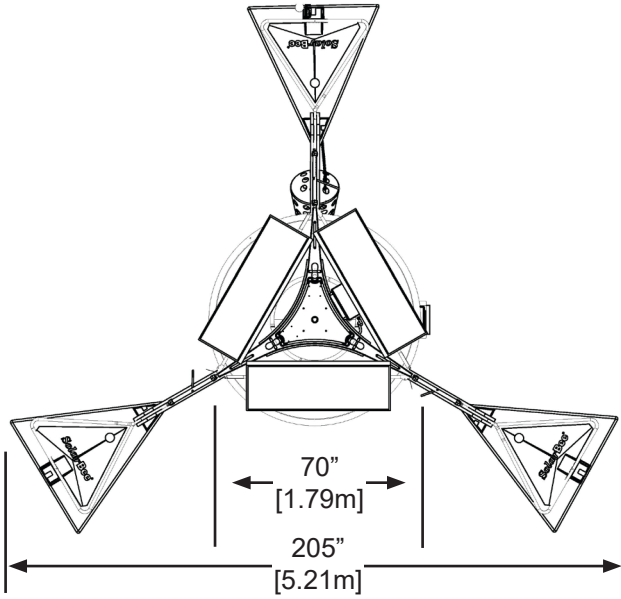

Appendices



Appendix

Additional Component Information

Technical Data Sheets

Technical Data Sheet

SB10000DM

Technology Description- Floating, solar powered, circulation equipment. Two mixing flows for maximum nutrient (N and P) reduction, in addition to BOD/TSS reduction in partial mix and facultative wastewater treatment systems. Day/night operation on solar only by utilizing a battery to store a battery to store excess daytime power for nighttime operation.

Materials of Construction - T316 stainless steel construction. Foam-filled high-density polyethylene (HDPE) floats. Thermoplastic rubber stainless steel reinforced intake hose. HDPE strainer. Concrete mooring blocks are encapsulated in HDPE.

Machine Size / Weight - Assembled machine is 16 feet (5 m) in diameter and weighs 850 pounds (380 kg).

Drive System - High torque, direct drive (no gearbox), low voltage brushless D.C. motor.

Minimum Operating Depth - 36 inches (0.9 m). No damage to machine or bottom of reservoir when run dry in shallow water.

Flotation System - Three floats in triangular pattern each with an adjustable float arm for proper vertical positioning, total float buoyancy of 1,450 lbs (660 kg).

Rotating Assembly - Removable assembly with easy access to motor and digital controller. Impeller handles 4-inch (10 cm) spherical solids. Oil-filled (food grade) teflon freeze sleeve with o-rings, shaft. Rotational indicator on shaft.

Power Supply/Control System - *Photovoltaic (PV) Solar Panels are protected from bird fouling with bird deterrent kit.*

PV Solar Panels: 3 X 80-watt photovoltaic solar panels. Onboard battery storage for day/night operation.

Electronic Controller: Digital solid-state controller, mounted in weather-tight (NEMA 4X) enclosure with externally fused disconnect. SCADA output through RS-232 serial communication (Modbus RTU), DB9 male connection point inside enclosure. Wireless options available, not included.

Wiring: Corrosion-resistant industrial cord with molded watertight connectors that are indexed to prevent improper wiring.

Flow Rates - *Flow Rates at full speed at 10 feet (3.0 m) diameter.*

Direct Flow Rate: 3,000 gallons per minute (12,000 liters per minute).

Induced Flow Rate: 7,000 gallons per minute (26,000 liters per minute).

Combined Flow Rate: 10,000 gallons per minute (38,000 liters per minute).

Lower Mixed Zone Flow Rates - *Flow Rates at full speed at center of machine..*

Direct Flow Rate - Day: 150 gallons per minute. (600 liters per minute).

Direct Flow Rate - Night: 150 gallons per minute. (600 liters per minute).

Fluid Intake Assembly - Lower Mixed Zone - *Intake hose assembly bolted to bottom of structural assembly.*

Hose System: 12 inch (31 cm) diameter X 20 feet (6 meter).

Intake Type: Inverted bell shape strainer with 3 inch (7.6 cm) holes.

Intake Depth Adjustment: There is no adjustment necessary for fluctuations in water level. Weight and flotation of the 'J' bend of hose keeps intake above sludge at all operation depths. Strainer can be chained up higher if desired.

Fluid Intake Assembly - Upper Mixed Zone - *Fixed horizontal plate bolted to bottom of structural assembly.*

Intake Type: Fixed horizontal plate with 12-inch (31 cm) openings.

Intake Depth Adjustment: No adjustment necessary. Horizontal inflow from 25-inch (64 cm) below distribution dish.

Anchoring - (1) Two mooring blocks tethered together with SS chain and attached to structural member on unit or
(2) Tethered to shore with SS cable.

Ice Protection - Freeze sleeve and positive pumping under distribution dish to maintain circulation.

Accessories Available - (1) Supplemental Shore Power Kit, (2) Chemical Injection Kit, (3) Marker Light Kit

Shipping Size / Weight -

• **Crate -** 87 inch W X 87 inch L X 65 inch H (2.2 m x 2.2 m x 1.7 m) / 1,500 pounds (680 kg)

Exact weight and dimensions varies dependent on machine configuration.

Maintenance / Warranty - Minimal maintenance. Limited 2-year parts and labor warranty.

Patent Pending

Subject to change without notice.

©2024 IXOM Watercare Inc. | www.ixomwatercare.com | 866 - 437 - 8076 | watercare@ixom.com

182_10589_20240108

O&M_SB10000DM_10592_20241127 - 47

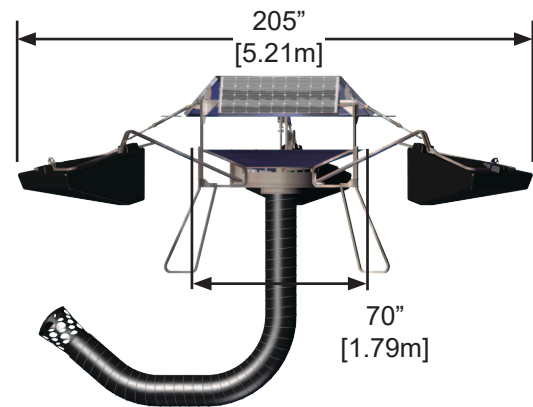

Figure 1: SB10000DM

SB A-Series Control Panel

Part Number: 14300000

Description

The SB A-Series Control Panel enables the solar powered SB units to charge a deep cycle 12VDC battery and allow continuous operation. Contains control board for autonomous control, data logging and SCADA monitoring. Also takes advantage of MPPT charging technology to ensure maximum solar power is utilized. Robust DC-DC converter to power the impeller motor.

Power Source Required

1 to 3 - 90 W, 36 Cell Monocrystalline Solar Panels
1 - 212 Ah, 12VDC Deep Cycle Battery

SCADA

A SCADA output is available as a standard in RS-232 DB9 male connection and follows Modbus RTU protocol. Accessory SCADA options for other output formats may be available upon request.

SCADA Monitoring Accessories

Additional SCADA monitoring accessories are available upon request. These include, but are not limited too, RS232-RS485 converter, wireless radios, and Modbus Master converter.

Enclosure

10 inch X 8 inch X 6 inch, NEMA 4X Fiberglass
Mounting Feet Hole Pattern: 7.01" W X 11.19" H
Back Plate Hole Pattern: 6.25 inch W X 8.25 inch H

Shipping Size/Weight

16 inch X 13 inch X 11 inch, 16 lbs

Warranty

Reference SB Limited Replacement Warranty.

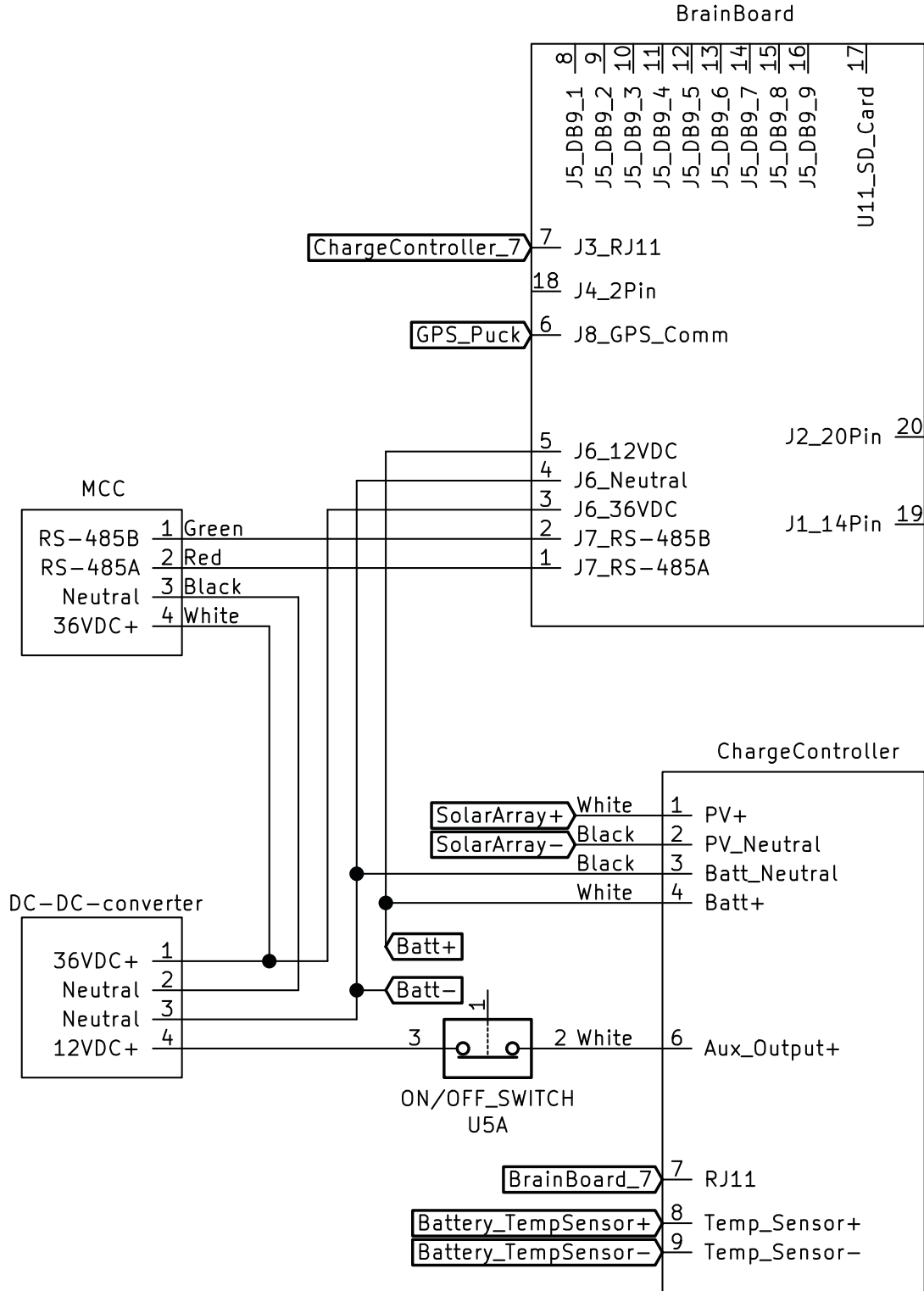

Figure 1: SB A-Series Control Panel, External



Figure 2: SB A-Series Control Panel, Internal

SB Series A-Box Wiring Schematic



Electrical

Electrical Schematic

SB Series - A Box

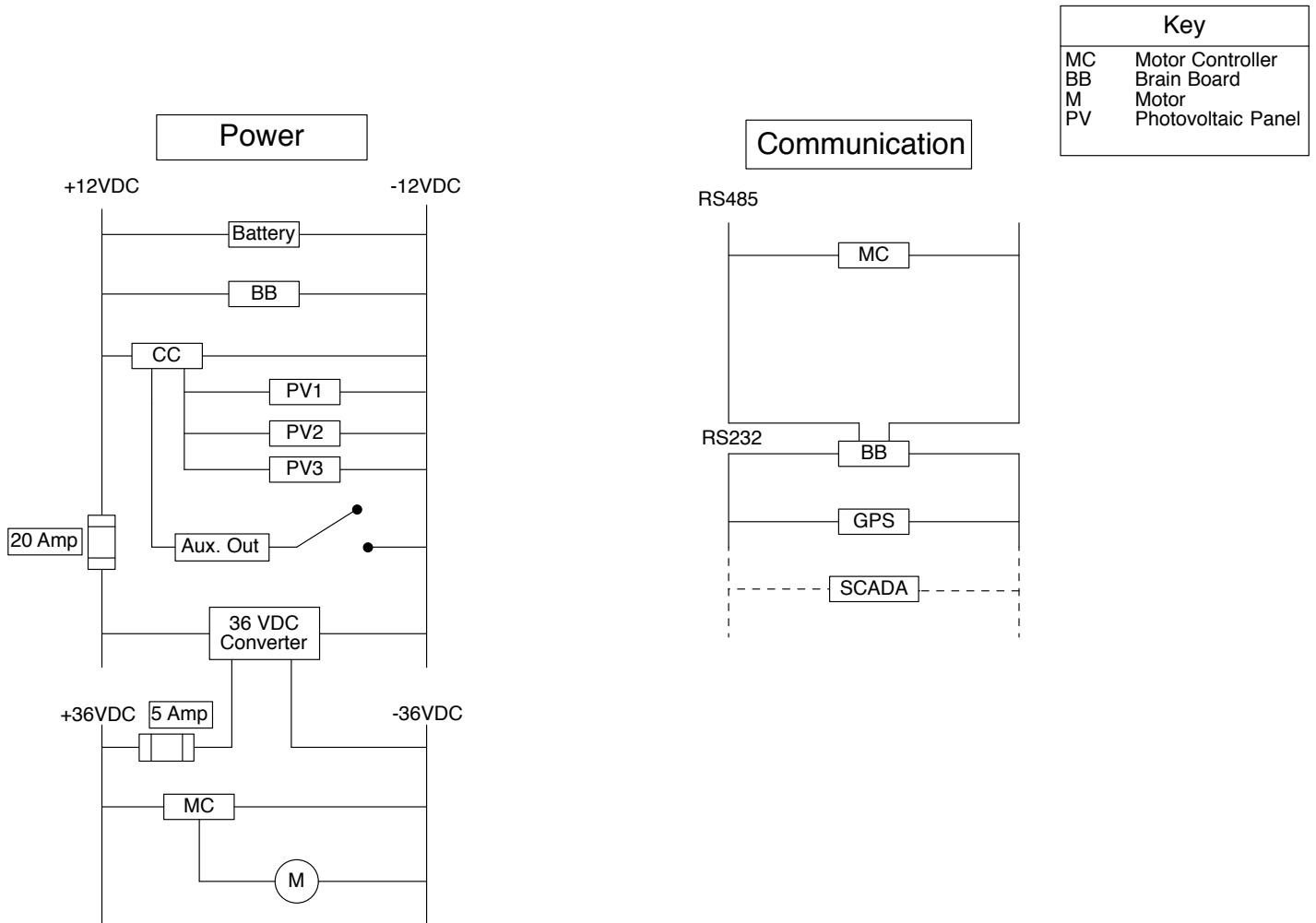

SB B-Series Control Panel

Part Number: 14300005

Description

The SB B-Series Control Panel enables the solar powered SB units to charge a deep cycle 12VDC battery and allow continuous operation. Also utilizes supplemental grid power from the shore. Contains control board for autonomous control, data logging and SCADA monitoring. Also takes advantage of MPPT charging technology to ensure maximum solar power is utilized. Robust DC-DC converter to power the impeller motor.

Power Source Required

- 1 to 3 - 90 W, 36 Cell Monocrystalline Solar Panels
- 1 - 212 Ah, 12VDC Deep Cycle Battery
- 1 - Supplemental 36VDC Shore Power (Additional Shore Power Box Needed)

SCADA

A SCADA output is available as a standard in RS-232 DB9 male connection and follows Modbus RTU protocol. Accessory SCADA options for other output formats may be available upon request.

SCADA Monitoring Accessories

Additional SCADA monitoring accessories are available upon request. These include, but are not limited too, RS232-RS485 converter, wireless radios, and Modbus Master converter.

Enclosure

10 inch X 8 inch X 6 inch, NEMA 4X Fiberglass
Mounting Feet Hole Pattern: 7.01" W X 11.19" H
Back Plate Hole Pattern: 6.25 inch W X 8.25 inch H

Shipping Size/Weight

16 inch X 13 inch X 11 inch, 16 lbs

Warranty

Reference SB Limited Replacement Warranty.

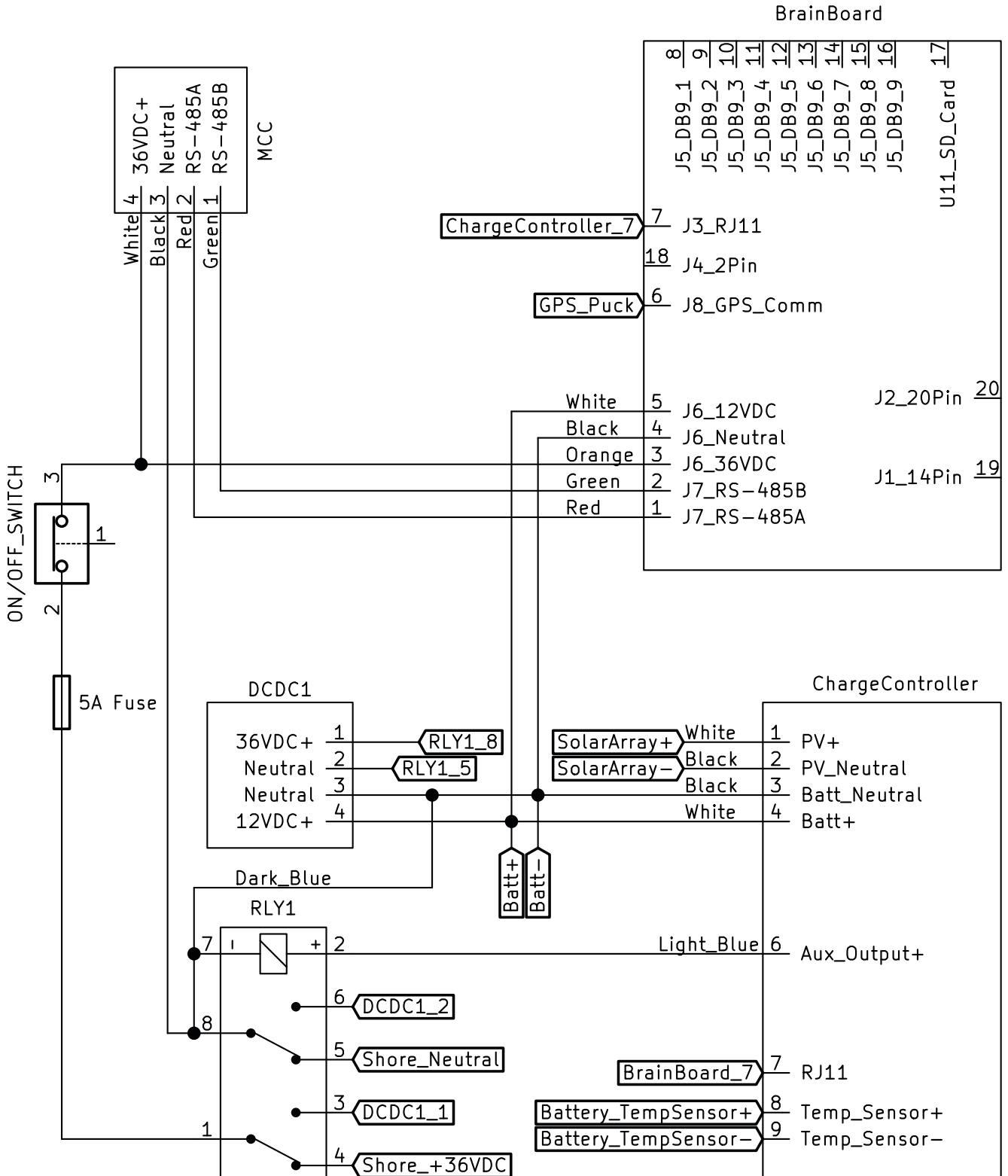

Figure 1: SB B-Series Control Panel, External



Figure 2: SB B-Series Control Panel, Internal

SB Series B-Box Wiring Schematic



Electrical Schematic

SB Series - B Box - Grid Boost

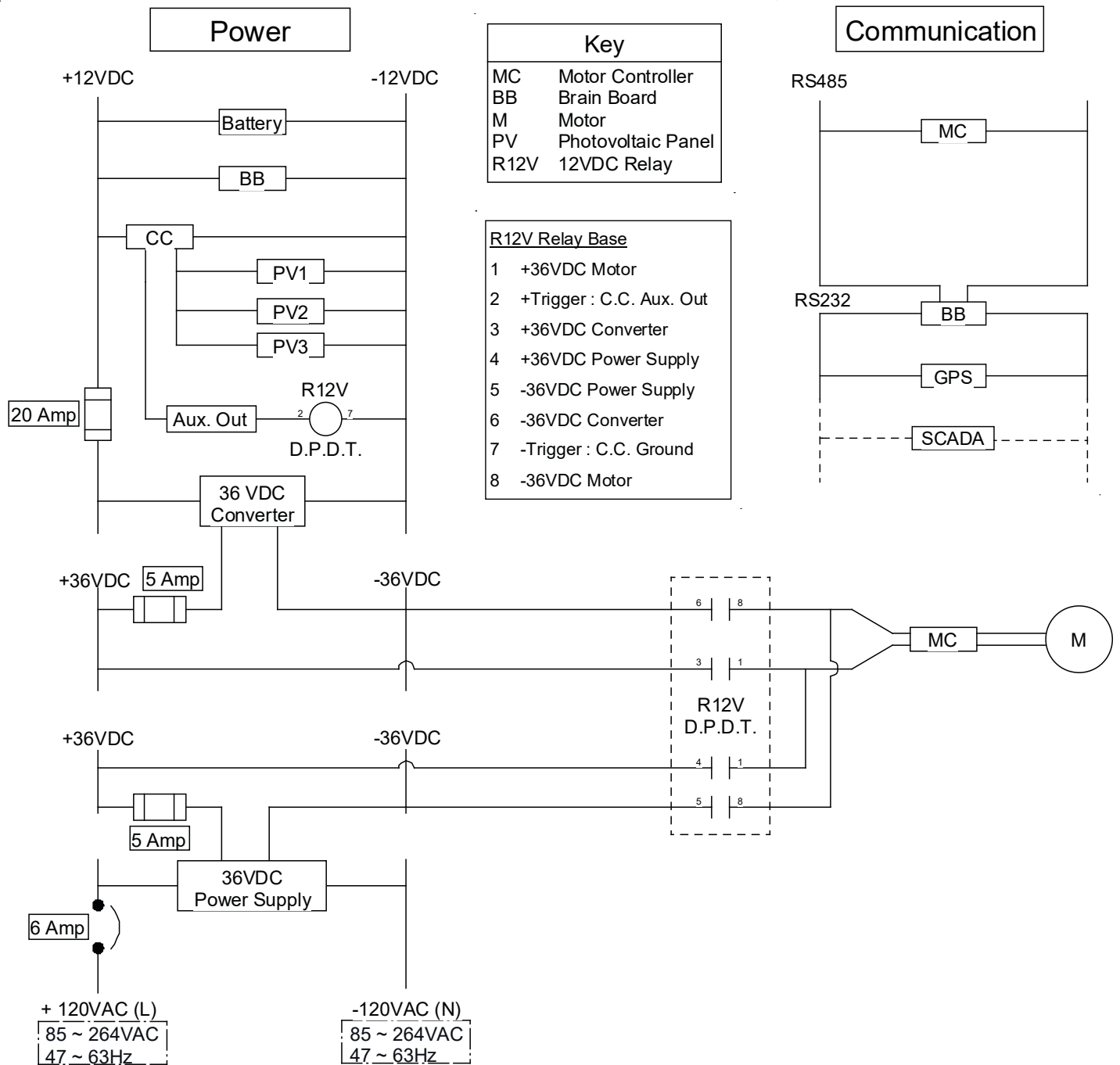

SolarBee Standard SCADA Output

The SolarBee digital controller comes standard with the following SCADA output capabilities: Controller shall have RS-232 serial communication (Modbus RTU), DB9 male connection point.

Parameters available for monitoring:

- 1) System Status (OK or Fault)
- 2) Visual Status Indicator
- 3) Motor RPM & Direction
- 4) Motor Current
- 5) Battery Voltage
- 6) Input Charge Current

SCADA Accessory Packages:

- Wireless Radio
- Analog Output
- RS-232 to RS-485 Converter
- LED RPM Indicator

SolarBee Monitoring Setup Information

The SolarBee is a modbus RTU slave device with a factory programmable slave ID. The ID can be changed in the field with a properly programmed SD card. Contact Ixom Watercare, Inc. Customer Service for assistance.

Serial Interface

Type: RS-232

Connector: 9 pin male D-Sub

Pin assignments:

- | | |
|---|---|
| 1 | n/c |
| 2 | RXD Receive Data Input |
| 3 | TXD Transmit Data Output |
| 4 | n/c |
| 5 | Signal Ground |
| 6 | n/c |
| 7 | n/c |
| 8 | n/c |
| 9 | +12VDC, 1 Amp max
(Can be used to power some serial devices) |

Serial/modbus Communication Parameters

Rate: 19200 Baud

Bits/byte: 8

Stop bits: 1

Parity: N (none)

Handshake: None

Time between bytes sent to SolarBee controller:
No greater than 20 milliseconds

Time between commands sent to SolarBee controller:
At least 50 milliseconds

Read Holding Register

The SolarBee supports modbus Function 3 - Read Holding Register.

A properly formatted "Read Holding Register" modbus message will be replied to with holding register data. The "Read Holding Register" message consists of the SolarBee slave address, the function (3), two bytes of register address, two bytes of number of points, and the CRC. The address of the holding registers can be found in the table on the next page.

The format of the reply consists of the SolarBee slave address, the function (3), a byte count (number of data bytes), two bytes of data for each of the requested points, and the CRC.

When monitoring several SolarBees on the same modbus network, query them sequentially. That is, query one SolarBee and wait for its response, query the next SolarBee and wait for its response, etc. Querying the SolarBees in a manner such that the query/response messages can overlap or collide will cause inconsistent communication.

SolarBee Standard SCADA Output

Description of Holding Registers in Order of Importance

(Memory Table starts at zero, 0)

Register Address (Base 10)	Status Item	Description
4	Current Epoch High	This is the date and time data for the SolarBee. The format is the same as that of the "Unix epoch", (Epoch High * 65536 + Epoch Low), where the value is the number of seconds since 00:00:00 UTC on January 1, 1970. This value is set by the GPS hardware in the SolarBee controller. Querying register 5 and testing the response against the previous value is a good way to monitor the communication link between the modbus master and the slave SolarBee controller.
5	Current Epoch Low	
7	System Status	During normal operation this value is 0 (Zero). Any other number indicates an error. It is important to monitor this register since the SolarBee controller reports last known values it received from subsystem modules. For example, if the SolarBee controller loses communication with the motor control module, it will indicate this in this system status register but continue to report the last known motor RPM and current values.
9	Visual Status Indicator	This value gives an indication of the SolarBee controller health blink indicator. During normal operation the following values will appear: 0 = (1 Blink Green = Healthy System) 32 = (2 Blink Yellow = Low Battery, Healthy System) 1 = (1 Blink Red = AntiJam Sequence), high current may self correct 256 = (1 Blink Green & 1 Blink Yellow = Acquiring GPS Satellite Signal) Any other indication requires attention: 2 = (2 Blink Red = 36V Out Of Range) 3 = (3 Blink Red = Motor Controller Communication Error) 4 = (4 Blink Red = Charge Controller Communication Error) 5 = (5 Blink Red = Low Battery Limit) 16 = (1 Blink Yellow = High Motor Current) 48 = (3 Blink Yellow = Temperature Out Of Range) 64 = (4 Blink Yellow = 5V Out Of Range) 80 = (5 Blink Yellow = GPS Communication Error)
10	Motor Speed	The unit for this value is RPM in hundredths. To obtain RPM, divide the value by 100.
11	Motor Direction	The value of 0 indicates that the motor will be stopped, the value of 1 represents movement in the forward direction, whereas the value of 3 indicates reverse movement. Viewed from behind or above the motor clockwise motion is "forward".
12	Motor Current	The unit for this value is milliamps.
13	Battery Voltage	The unit for this value is Volts. The value is scaled using this formula: value / 10.
14	Input Current	The current that is input to the controller via the solar array or shore power connections. The unit for this value is Amps. The value is scaled using this formula: value / 10.

SolarBee Standard SCADA Output

Logic Diagram

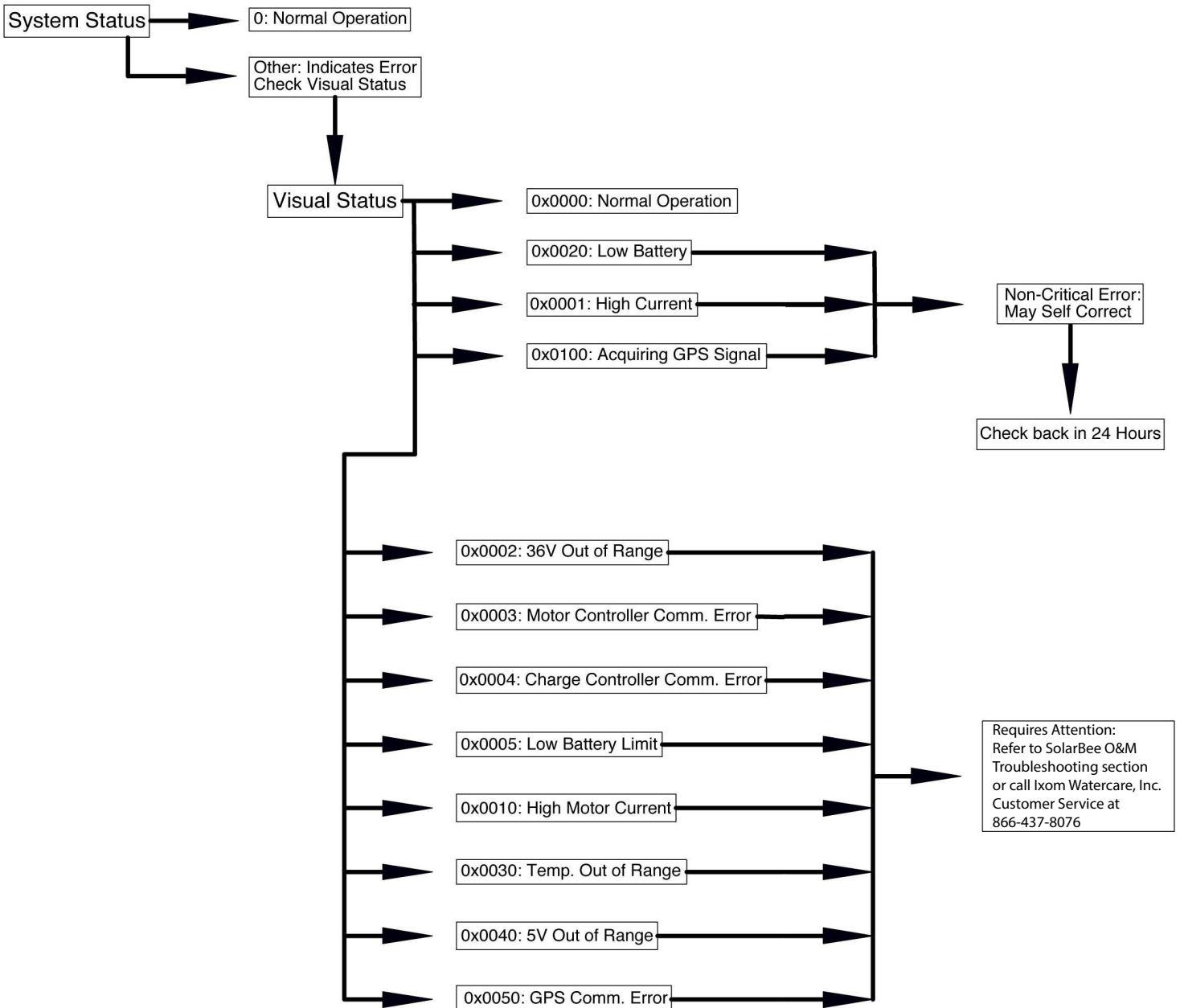

SolarBee SCADA

Integration



System Status for SolarBee SCADA Integration

Register Address 7 (Base 10)

Value of Zero indicates normal, healthy operation. Any other value indicates a subsystem or multiple subsystem errors. See below.

Binary Designation(s)	Decimal Value	Error Meaning
Bit 0 = 1	1	GPS Communication (Comm) Error
Bit 1 = 1	2	Charge Controller Comm Error
Bits 0 and 1 = 1	3	GPS Comm and Charge Controller Comm Error
Bit 2 = 1	4	Motor Comm Error
Bits 0 and 2 = 1	5	GPS Comm and Motor Comm Error
Bits 1 and 2 = 1	6	Charge Controller Comm and Motor Comm Error
Bits 0, 1, and 2 = 1	7	GPS Comm, Charge Controller Comm, and Motor Comm Error
Bit 3 = 1	8	Analog Out of Range (OOR) Error
Bits 0 and 3 = 1	9	GPS Comm and Analog OOR Error
Bits 1 and 3 = 1	10	Charge Controller Comm and Analog OOR Error
Bits 0, 1, and 3 = 1	11	GPS Comm, Charge Controller Comm, and Analog OOR Error
Bits 2 and 3 = 1	12	Motor Comm and Analog OOR Error
Bits 0, 2, and 3 = 1	13	GPS Comm, Motor Comm, and Analog OOR Error
Bits 1, 2, and 3 = 1	14	Charge Controller Comm, Motor Comm, and Analog OOR Error
Bits 0, 1, 2, and 3 = 1	15	GPS Comm, Charge Controller Comm, Motor Comm, and Analog OOR Error

For Customer Service, contact Ixom Watercare, Inc. Main Office and Service Center at 866-437-8076.

Visual Status Indicator Priority Levels

Register Address 9 (Base 10)

Table 4 - Status Indicator Priority Levels		
Priority Level	LED Behavior	Indication / Cause
Priority 1	5x Red	Battery Voltage is Out of Range: Vbat < Analog Battery Monitor Lower Limit (11.4V) or Vbat > Analog Battery Monitor Upper Limit (17.5V)
Priority 2	1X Red	AntiJam Mode has been activated: Motor Current > AntiJam A Trigger Current (4.5A) or Motor Controller Error has been received.
Priority 3	2X Red	36V Supply is Out of Range: 36V supply < Analog 36V Monitor Lower Limit (33.0V) or 36V supply > Analog 36V Monitor Upper Limit (39.0V). If the Charge Controller has the Auxiliary Output turned off, this error is not displayed. * Improper power down and power up sequence. Charge controller locked out. (e.g. battery replacement).
Priority 4	3X Red	Motor Controller not communicating properly. If the Charge Controller has the Auxiliary Output turned off, this error is not displayed.
Priority 5	4X Red	Charge Controller not communication properly.
Priority 6	1X Yellow	Motor Current > Visual Motor Current Threshold (3.5A)
Priority 7	2X Yellow	Vbat < Visual Low Battery Threshold (12.1V)
Priority 8	3X Yellow	Temperature Reading is Out of Range: Temp < Analog Temperature Monitor Lower Limit (0°F) or Temp > Analog Temperature Monitor Upper Limit (176°F)
Priority 9	4X Yellow	5V Supply is Out of Range: 5V supply < Analog 5V Monitor Lower Limit (4.5V) or 5V supply < Analog 5V Monitor Upper Limit (5.5V)
Priority 10	5X Yellow	GPS Unit not communicating properly

Large 14" Brushless Motor

Motor Features

Technology Description- Designed for Solarbee and Gridbee circulation equipment. The brushless direct drive motor provides high torque, eliminates costly gearboxes, and provides high reliability. The motor requires no brush replacement, no lubrication, and no routine maintenance. An iron free stator eliminates iron saturation to provide long life. It also provides a smooth, vibration free operation. Quite operation at low speeds. Operational power requirements utilize low voltage DC power. Using hall effects for electronic communication. Provides effective use of solar and DC energy.

14" Motor Specifications		
Size	14-inch (36cm) diameter X 6-inch (15cm) height	
Weight	75 lb (34 kg)	
Housing	Sealed 356-T6 Cast Aluminum	
Shaft	Stainless Steel: V-ring seal	
Thrust Bearing	L10: 100,000 hrs. Stainless Steel	
Motor Control	Anti-Corrosive coating on flux returns and magnets Encapsulated stator Conformal coating on commutation circuit board Hall Effect Commutation	
Receptacle	#16-9, 7A, 600V AC/DC, IP68, NEMA 6P, UL/CSA	
	Normal Operation	Maximum Motor Ratings
Current	Less Than 1.0 Amp	7.0 Amps
Voltage	36 VDC	36 VDC
Torque	3ft-lb (0.4 N-m)	30 ft-lb (40 N-m)
Power	1/20 HP (36 W)	1/3 HP (250 W)
Environment	-40 to 140°F, freeze resistant, 100% humidity, splash and condensation resistant	

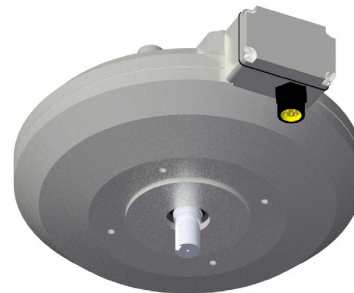

Shipping Size/Weight

- 16" x 16" x 9", 80lbs.

Maintenance / Warranty - No routine maintenance. Limited 2-year parts and labor warranty.

Technical Data Sheet



Sun Xtender Submersible Solar Battery

PART NUMBER: 14285212

DESCRIPTION:

Core Manufacturer: Concord Corp.
Sun Xtender Solar Battery, VRLA-AGM Deep Cycle Battery for Off Grid and Grid Tied Systems

CONSTRUCTION:

Thick walled polypropylene copolymer container and sealed cover. PolyGuard protection used around the positive plate and AGM prevents shorting from shock and vibration. Sun Xtender is the only battery offering this added layer of protection. Recombinant gas Sun Xtender® Series solar batteries are valve regulated lead acid (VRLA) batteries, providing explosion resistance.

APPROVALS:

UL 1989 (Standby Battery), File Number MH-17983. Sun Xtender® Series batteries ship Hazmat EXEMPT. Complies with 49 CFR 173.159a, DOT HMR49, ICAO and IATA, Special Provisions S.P.A67 & A48.

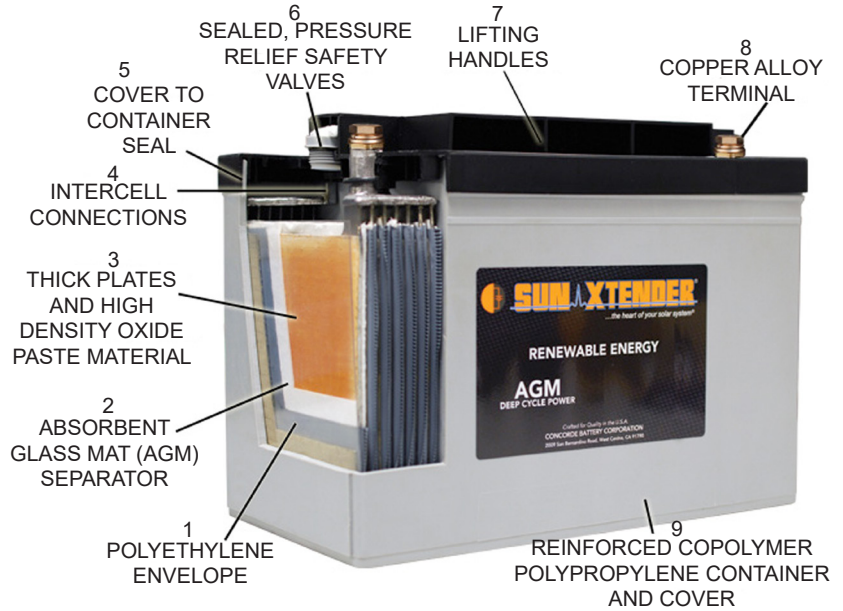

1. Eliminates internal shorts caused by shock, vibration & dendrite growth.
2. Custom designed and manufactured to provide superior wicking characteristics for electrolyte retention.
3. Insures long life, excellent cycling capability.
4. Massive "over-the-partition" weld increases the weld strength & provides low resistance connection path.
5. Strong, epoxied tongue & groove cover/container seal will not separate even under extreme temperature & pressure changes or vibration.
6. Operates in any orientation without leaking. Maintenance-free: never requires water additions.
7. Easier handling, carrying & installation.
8. Provides low resistance electrical connection (copper-to-copper), non-corrosive, increased environmental protection & personal safety- no exposed lead.
9. High impact resistance and resists bulging even under severe overcharge and temperature. Shock proof and freeze tolerant.

4 PIN MALE FACE VIEW

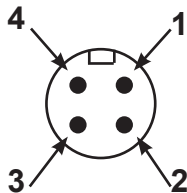

- | | | |
|------------|-------|--------------------|
| 1 - 12 AWG | Black | -12VDC Power |
| 2 - 12 AWG | Green | Temperature Sensor |
| 3 - 12 AWG | Red | Temperature Sensor |
| 4 - 12 AWG | White | +12VDC Power |

Electrical and Physical Properties:

Voltage: 12V
Weight: 145 lb (65.77 kg)
Battery Series: 12 Volt Sun Xtender Series
Cord Length: 7 ft T316 SS Sheathed
Self Discharge Rate: 1-3%/month - remains stable over life.
IP Rating: IP68
Nominal Capacity Ampere Hours:
 @ 25° C (77° F) to 1.75 Volts per cell

24 Hr Rate: 212Ah
 48 Hr Rate: 235Ah
 72 Hr Rate: 244Ah

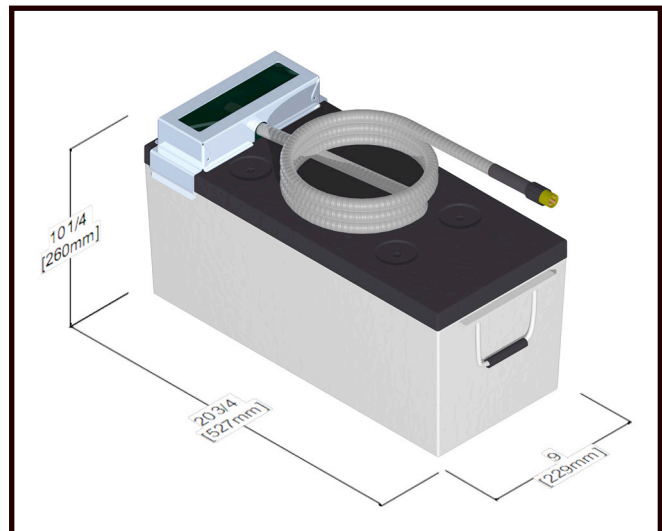

Warranty



Solar SB Mixers

Limited Replacement Warranty

SolarBee SB Mixers. All new and factory-refurbished SolarBee SB mixers and circulators are warranted to be free of defective parts, materials, and workmanship for a period of two years from the date of installation. SolarBee SCADA and any optional accessories are considered “buyout” items for Ixom, and as such include a warranty against defects in material and workmanship for two years from the date of purchase. Parts that are determined by Ixom to be defective in material or workmanship under normal use during the two year warranty period will be repaired or replaced. Any shipping charges that may apply are the responsibility of the customer. This warranty is valid only for SolarBee equipment used in accordance with the owner’s manual, and consistent with any initial and ongoing factory recommendations. This warranty is limited to the repair or replacement of defective components only and does not apply to normal wear and tear. If the factory’s service crews performed the original on-site placement and startup, then this warranty also includes labor. Where labor is included, in lieu of sending a factory service crew to the site for minor repairs, Ixom may choose to send the replacement parts to the owner postage-paid and may pay the owner a reasonable labor allowance, as determined solely by Ixom, to install the parts. There is no liability for consequential damages of any type. The warranty that is submitted and provided with the purchased equipment is the valid warranty.

Terms applicable to all equipment. This Limited Replacement Warranty is subject to the terms of Ixom’s General Terms and Conditions of Sale. In the event of any inconsistency between the terms of this Limited Replacement Warranty and Ixom’s General Terms and Conditions of Sale, the terms of this Limited Replacement Warranty shall prevail to the extent of that inconsistency.

Protect Your Investment With The Ixom Service Program

Comprehensive Damage Repair

Damage which occurs to your Ixom manufactured equipment in the normal course of operation will be repaired or replaced including supply and installation of structural repairs and replacement parts in accordance with Ixom's standard terms & conditions.

Trained & Experienced Service Technicians

The Ixom Service Program allows our customers to take advantage of our highly trained service technicians. We have the equipment, experience and training to ensure the machines are well maintained while following OSHA regulations. Our dedication to safety and high level of training has earned us the prestigious SHARP recognition award time and time again. We have the means to safely service the equipment whether in municipal water tanks, lakes, reservoirs, or wastewater ponds & basins.



Guaranteed Annual Onsite Maintenance

Ixom service personnel will perform a minimum of one (1) onsite equipment inspection & maintenance per yearly term of the service contract including mechanical, structural, and electronic components of Ixom manufactured equipment.

On-Site Crew Response for Critical Application and Operational Service Issues

If service issues arise, the customer may be asked to perform a basic machine inspection and discuss results with Ixom's Customer Service Department. In some cases, the customer may be asked to perform minor tasks (i.e., cleaning, basic troubleshooting, and replacing minor parts). If replacement parts are needed, the factory will ship them out at no cost. For more serious application and service issues, Ixom will dispatch service personnel to resolve the issues onsite.



Removal, Storage, and Redeployment of Equipment

For situations when Ixom equipment needs to be removed, stored, and redeployed, services can be offered at a discounted rate.

Access to On-Staff Water Quality Experts

Ixom employs many experts in the water quality field including specialized areas such as limnology, hydrology, wastewater, biology, and engineering. Our water quality personnel are available for data analysis and troubleshooting when you need it.



Contact us for a quote!

Call +1 866-437-8076 or email us at watercare@ixom.com

IXOM

WATERCARE

Nationwide Installation & Service

EVERYONE DESERVES GREAT CUSTOMER SUPPORT

Ixom Watercare earns customer trust with unparalleled service start to finish. Every department in Ixom is dedicated to the support of our Customers and the improvement of water quality. Complete life cycle support is much, much more than a returned phone call or an email. It centers around direct access and communication to those who can help when help is needed from the beginning of a project throughout the life of the equipment.

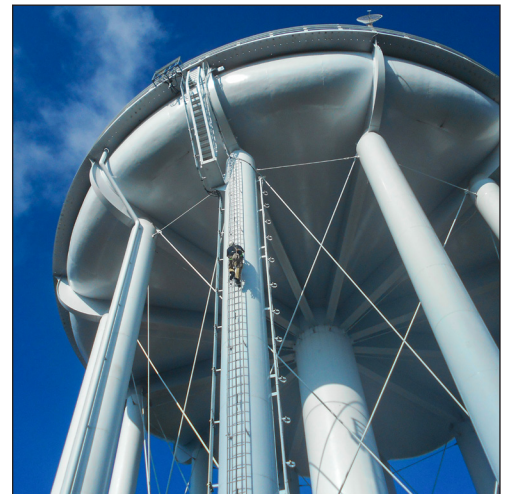

ABOUT IXOM

Ixom combines innovative water quality solutions with top notch manufacturing and nationwide in-field service capabilities to create trusted, full circle support our Customers depend on.

We design and manufacture many trusted brands including GridBee®, SolarBee®, MIEX®, and ResidualHQ® for use across the water quality spectrum. This includes solutions for Water Treatment, Distribution Treatment, Wastewater Treatment and Lakes & Source Water Reservoirs.

Ixom has thousands of installations and is an industry-leader solving water quality problems across the United States, Canada and the world.

Contact us today to discuss your water quality and service needs.

ixomwatercare.com
866-437-8076 • watercare@ixom.com