

SolarBee SB500PWc

Owner's Manual



Table of Contents



SolarBee SB500PWc Owner's Manual

Safety	1
Operation	4
Frame Assembly	5
Low Profile Stand Assembly	8
Features	14
Dual Tethering	22
Maintenance	23
Electrical	32
Troubleshooting	35
Parts Diagram	39
Dimension Drawing	40
Appendix	41
Service Program	42
Technical Specifications	43
Warranty	57
Service Program	58
Customer Service	59

Safety

IMPORTANT

**YOU MUST COMPLETELY
READ AND FULLY
UNDERSTAND THESE
INSTRUCTIONS BEFORE
INSTALLING, OPERATING,
OR SERVICING THIS UNIT.**

Be sure you have read all installation, operation, maintenance and safety instructions before you install, service or begin to operate this unit.

Accidents occur every year because of careless use of industrial equipment. You can avoid hazards by following these safety instructions, and applying some ordinary common sense when operating or servicing this unit.

Keep in mind that **full operator attention and alertness** are required when operating or servicing this unit.

USE COMMON SENSE!! Most accidents can be avoided by using **common sense and concentration** on the job being done.



Carefully read safety information when you see any safety symbols.

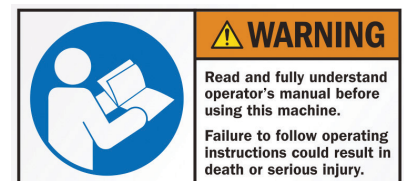

Safety

IMPORTANT

YOU MUST COMPLETELY READ AND FULLY UNDERSTAND THESE INSTRUCTIONS BEFORE INSTALLING, OPERATING, OR SERVICING THIS UNIT.

Identify all possible hazards. Determine what safeguards are needed and implement them. **Only you, the user,** understand your product and system characteristics fully. *The ultimate responsibility for safety is with you. Your safety ultimately rests in your hands.* Do your part and you will enjoy safe, trouble free operation for years to come. This instruction manual is not intended to include a comprehensive listing of all details for all procedures required for placement, operation and maintenance. If you have a question about a procedure or are uncertain about any detail, **Do Not Proceed.** Please contact Ixom Watercare Customer Service at **866-437-8076** to speak to a representative.



IMPORTANT!!!

Follow all federal and state laws in regards to safety regulations of working at heights, confined spaces, rescue, etc. as required by the U.S. Department of Labor, Occupational Safety and Health Administration. Use necessary PPE when placing and servicing this unit.



Thin Ice Hazard

WARNING: ICE SURROUNDING MACHINE MAY NOT SUPPORT WEIGHT, KEEP CLEAR OF THIN ICE.



ELECTRICAL HAZARD

WARNING: THIS EQUIPMENT CONTAINS HIGH VOLTAGE! ELECTRICAL SHOCK CAN CAUSE SERIOUS OR FATAL INJURY. ONLY QUALIFIED PERSONNEL SHOULD ATTEMPT PLACEMENT, OPERATION AND MAINTENANCE OF ELECTRICAL EQUIPMENT. REMOVE ALL SOURCES OF ELECTRICAL POWER BEFORE PERFORMING ANY SERVICE WORK TO THE MACHINE. USE PROPER LOCKOUT TAGOUT (LOTO) PROCEDURES TO ENSURE A SAFE WORK ENVIRONMENT.



Crush Hazard

WARNING: DO NOT REMOVE ANY FLOAT ASSEMBLY BOLTS OR PINS WHILE EQUIPMENT IS FLOATING IN WATER. EQUIPMENT MUST BE SECURELY SUPPORTED BEFORE PERFORMING SERVICE.



Rotating Hazard

CAUTION: KEEP BODY APPENANDAGES OR LOOSE CLOTHING AWAY FROM EQUIPMENT WHILE OPERATING. ENSURE EQUIPMENT IS OFF BEFORE ATTEMPTING SERVICE.



Entanglement Hazard

WARNING: ENSURE THAT PERSONNEL ARE CLEAR OF THE ELECTRIC CORD AND CHAIN TO AVOID ENTANGLEMENT.



Laceration Hazard

CAUTION: EDGES MAY BE SHARP AND CAUSE LACERATION IF PROPER CARE IS NOT USED.

Safety

Protect Yourself

It is important that you comply with all relative OSHA and local regulations while installing and performing any maintenance to the mixer circulation equipment.

Key OSHA Compliance Standards that must be followed (and not limited to) are:

- **1910.146 Permit-required confined spaces**
- **1910.147 Lockout/Tagout**
- **1926.500 Fall Protection**

Fall Protection Tips

- Identify all potential tripping and fall hazards before work starts.
- Look for fall hazards such as unprotected floor openings/edges, shafts, open hatches, stairwells, and roof openings/edges.
- Inspect fall protection and rescue equipment for defects before use.
- Select, wear, and use fall protection and rescue equipment appropriate for the task.
- Secure and stabilize all ladders before climbing.
- Never stand on the top rung/step of a ladder.
- Use handrails when you go up or down stairs.
- Practice good housekeeping. Keep cords, welding leads and air hoses out of walkways or adjacent work areas.

Refer to 29 CFR 1926.500 for complete regulations set by OSHA. Refer to your state's regulations if your state established and operates their own safety and health programs approved by OSHA.

Lockout Tagout

When the On/Off switch is in the "ON" position, the mixer may start up at any time if not already operating. The mixer's On/Off switch can be locked out by placing a pad lock thru the door latch of the controller after the switch has been turned to the "OFF" position. The On/Off switch is to be used as the emergency stop.



Permit-Required Confined Spaces

A confined space has limited openings for entry or exit, is large enough for entering and working, and is not designed for continuous worker occupancy. Confined spaces include underground reservoirs, ground storage tanks, elevated tanks, silos, manholes, and pipelines.

Confined Space Tips

- Do not enter permit-required confined spaces without being trained and without having a permit to enter.
- Review, understand and follow employer's procedures before entering permit-required confined spaces and know how and when to exit.
- Before entry, identify any physical hazards.
- Before and during entry, test and monitor for oxygen content, flammability, toxicity or explosive hazards as necessary.
- Use fall protection, rescue, air monitoring, ventilation, lighting and communication equipment according to entry procedures.
- Maintain contact at all times with a trained attendant either visually, via phone, or by two-way radio. This monitoring system enables the attendant and entry supervisor to order you to evacuate and to alert appropriately trained rescue personnel to rescue entrants when needed.

Refer to 29 CFR 1910.146 for complete regulations set by OSHA. Refer to your state's regulations if your state established and operates their own safety and health programs approved by OSHA.

Operation

Operation

SB Series

The SolarBee is designed to circulate water by bringing water from below and sending it out across the top in a thin layer causing a mixing effect. The laminar layer flows outward radially, in diverging “stream lines” from the distribution dish. As it does, vertical flow is induced in between the water being drawn below and the water above. At the level of the flow intake, water is drawn from all corners of the tank. As this lower layer of fluid makes its way inward with converging streamlines to the SolarBee, the water is forced upward, toward the surface, providing gentle mixing and de-stratification.

The SolarBee obtains all the energy it needs from the sun. Its solar panels provide power to the onboard battery which energizes the drive system’s controls and motor. Excess solar energy is stored during the day and used during the night allowing the SolarBee to operate during the night without being connected to the grid.

During operation, a visible flow can be observed coming off the distributor dish and spreading outward. The impeller of the SolarBee is designed to operate at full speed when there is sufficient sunlight and battery charge. The rpms may drop down some during the later night and early morning when the battery uses up its charge after a longer period of overcast days. In severe sunlight limited conditions, the machine may slow down or stop temporarily to protect the battery from damage.

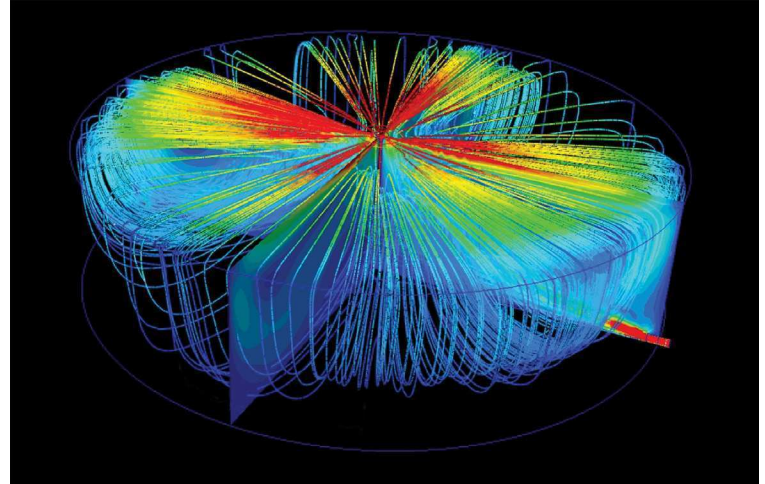

SolarBee Series Flow Model

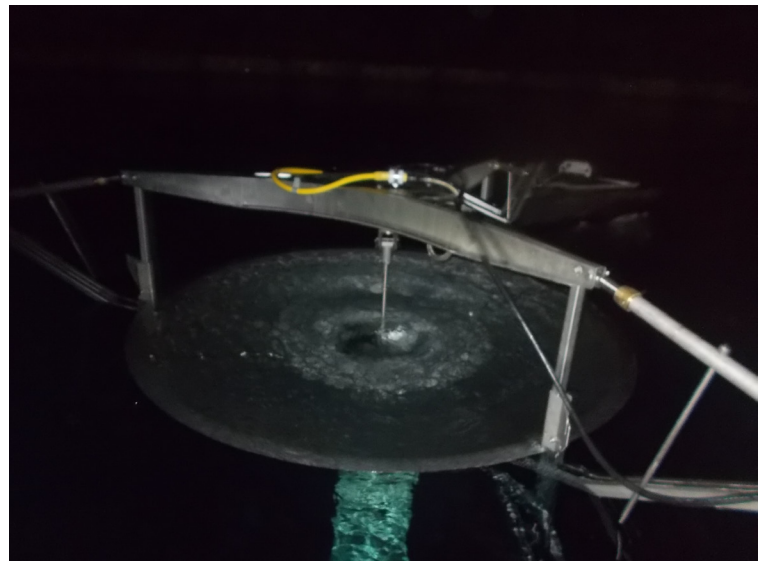

Flow Coming Off Distribution Dish

Small Frame Assembly

SB500PWc

SB500PWc Assembly

Assembly Diagram

IMPORTANT! The following pages give detailed instructions on how to assemble different portions of the machine; however, the order in which the components are assembled and entered into the reservoir may need to be altered based on the hatch size and whether the reservoir will be full or empty. For instance, the hose assembly to the base of the machine can be performed on the reservoir exterior prior to lowering the equipment inside if the hatch has a clear opening of **at least 24 inch diameter (60cm)**. A hatch this size or larger will allow the SB500PWc collapsible unit assembly to be installed without requiring float disassembly. For smaller hatches, the SB500PWc collapsible unit assembly will need to be broken down into multiple components and the hose assembly will need to be performed inside the reservoir. The following order of operations listed is based on a wet installation and small hatch opening. The float arm assembly is pre-attached at the factory.

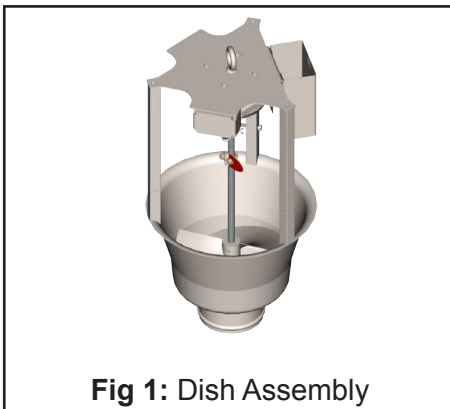

Fig 1: Dish Assembly

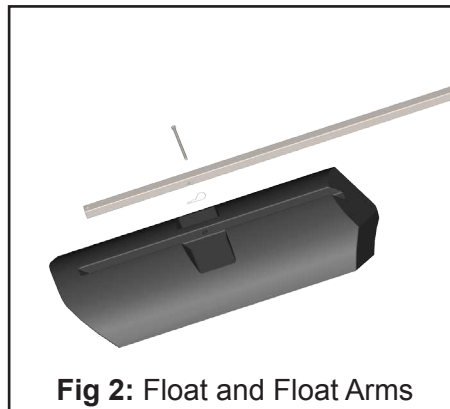

Fig 2: Float and Float Arms

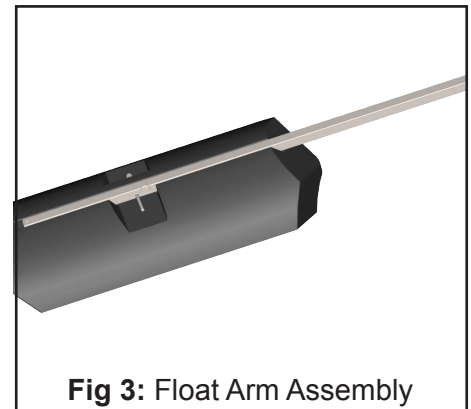

Fig 3: Float Arm Assembly

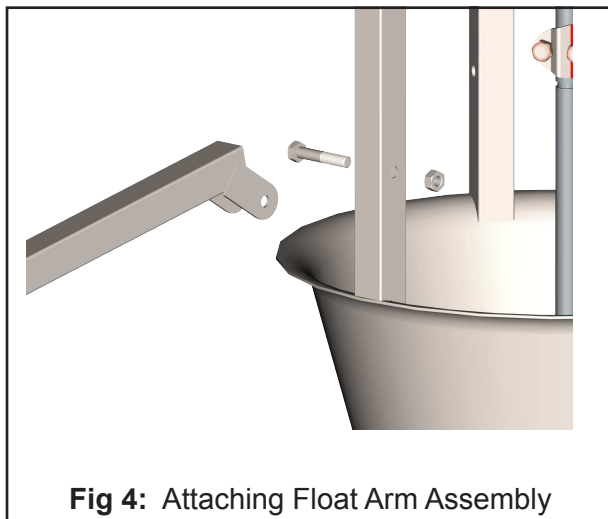

Fig 4: Attaching Float Arm Assembly

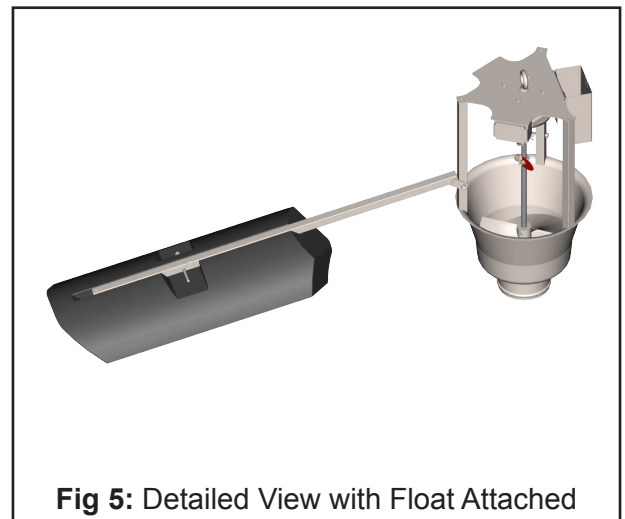

Fig 5: Detailed View with Float Attached

STEP 1: Locate the Dish Assembly, Floats and Float Arms. (See **Figure 1 & 2**)

STEP 2: Attach the Floats to the Float Arms. (See **Figure 3**)

STEP 3: Attach the Float Arm Assembly to the Dish Assembly with provided bolts and nylock nuts. (See **Figure 4 & 5**)

STEP 4: Repeat STEPS 1 through 3 for the other two floats.

Small Frame Assembly

SB500PWc

SB500PWc Assembly

Assembly Diagram

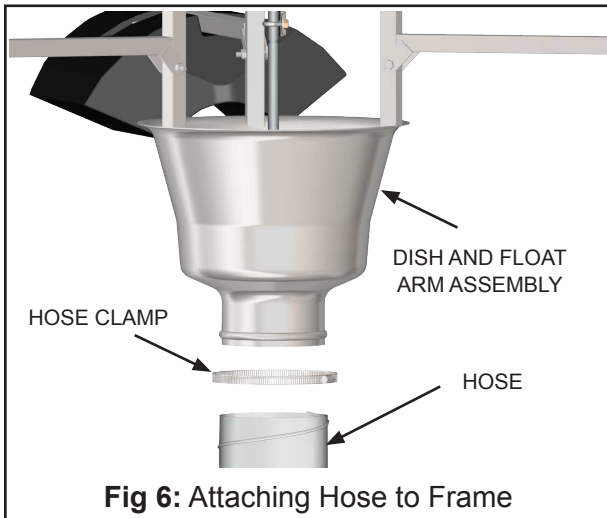

Fig 6: Attaching Hose to Frame



Fig 7: Hose Attached to Frame

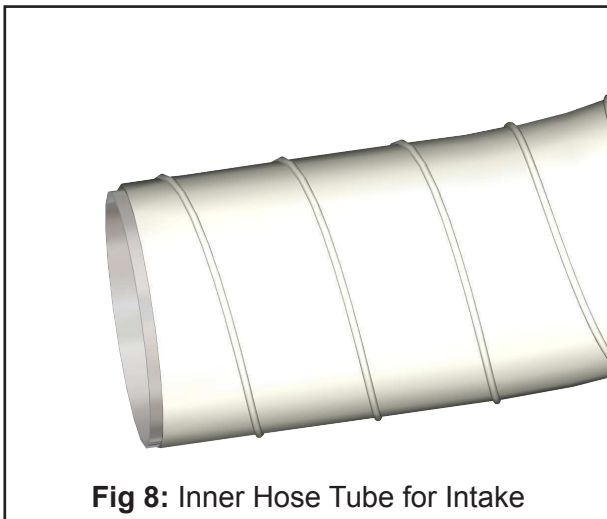

Fig 8: Inner Hose Tube for Intake

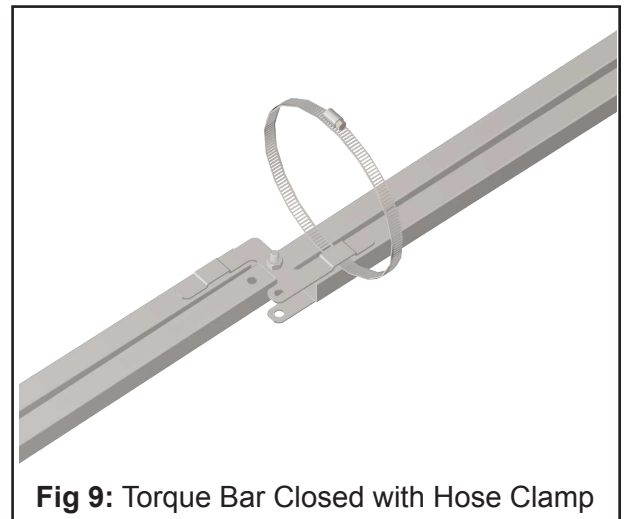

Fig 9: Torque Bar Closed with Hose Clamp

- STEP 1:** Locate one end of the hose section and place hose clamp over the end. Be sure that hose and clamp are installed above the metal rib of the flange and then tighten hose clamp as tight as possible to firmly secure hose. *(See Figure 6)*
- STEP 2:** Fasten Hose to bottom of machine by pushing hose up and all the way up above metal rib. *(See Figure 7)*
- STEP 3:** Locate end of the Hose Section opposite of the machine and insert the 6" Tube for 6" Hose Intake inside the end of the hose until approximately flush as shown. *(See Figure 8)*
- STEP 4:** Insert a 6" Hose Clamp and insert the end through one of the two small flat slots with Hose Clamp on top of the Torque Bar as shown. Either slot will work fine. *(See Figure 9)*

Small Frame Assembly

SB500PWc

SB500PWc Assembly

Assembly Diagram

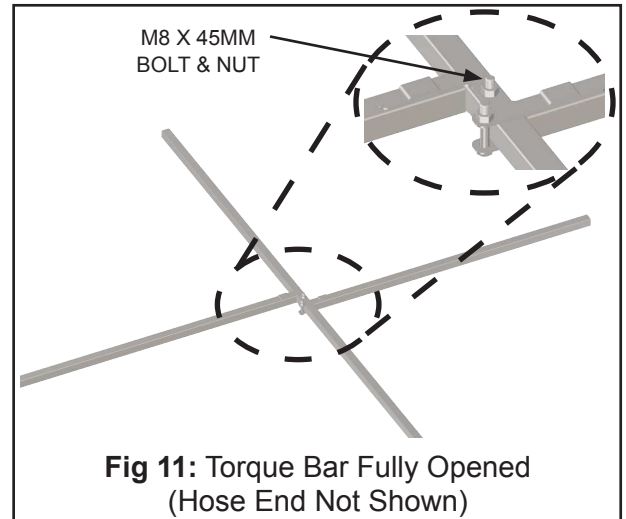
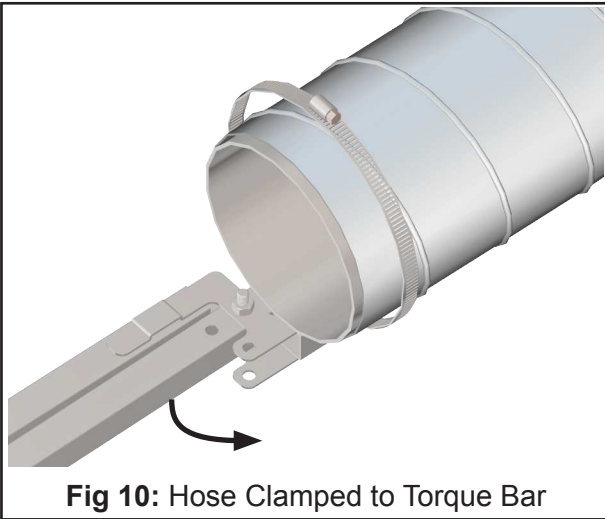

STEP 1: Position the end of the hose so that the clamp is centered over the 6" Hose Intake Tube. Secure the torque bar to the hose by tightening the hose clamp using a 5/16" nut driver. **(See Figure 10)**

STEP 2: Leave the Torque Bar in the folded position ready for entry through the hatch.

STEP 3: Lower the folded Torque Bar Assembly and Hose through the hatch to the entrant. The entrant then needs to expand Torque Bar into the fully opened position, and install an M8 x 45mm bolt and nylock nut through the torque bar tab to secure the torque bar in the open position. **(See Figure 11)**

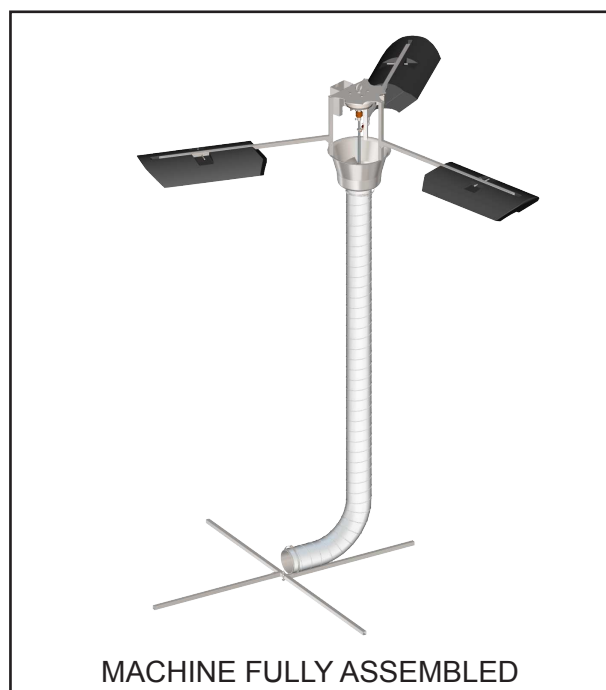

Low Profile Stand

Assembly Diagram

Low Profile Stand Assembly

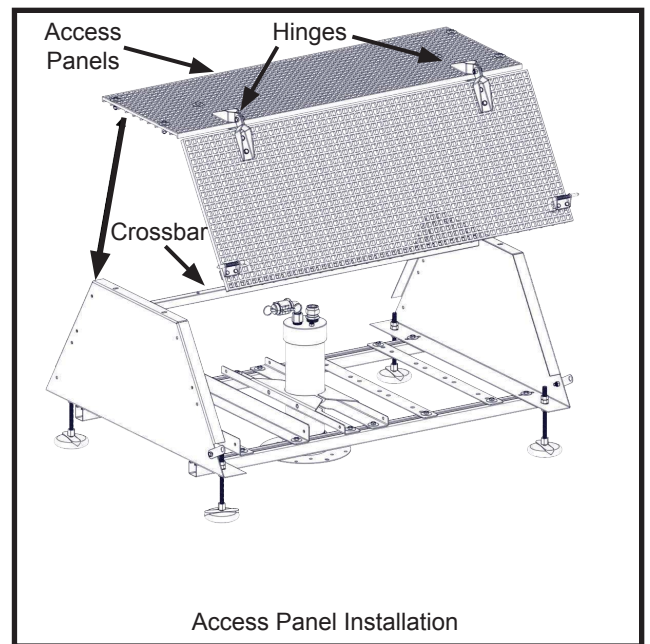
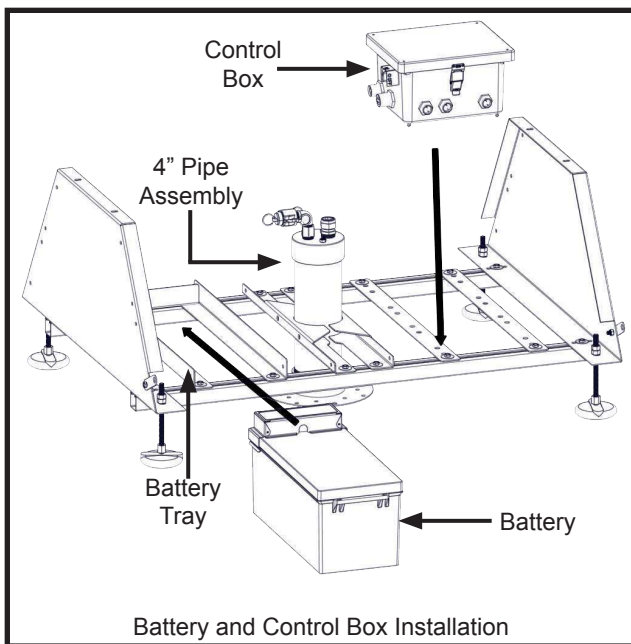
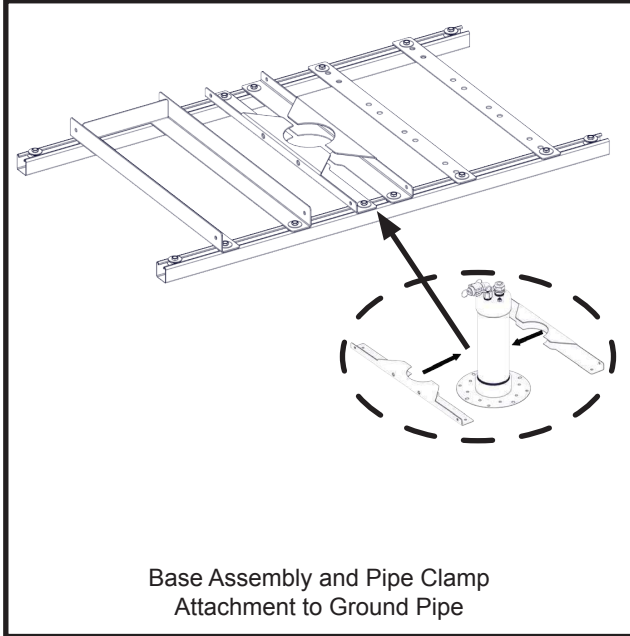

Low Profile Stand

Assembly Diagram

Low Profile Stand Assembly

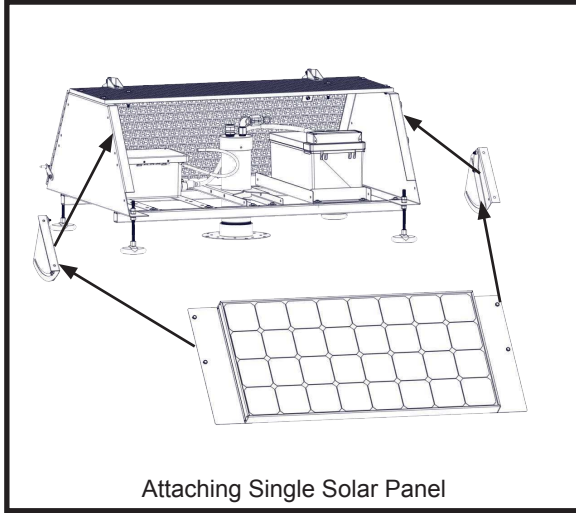

Attaching Single Solar Panel

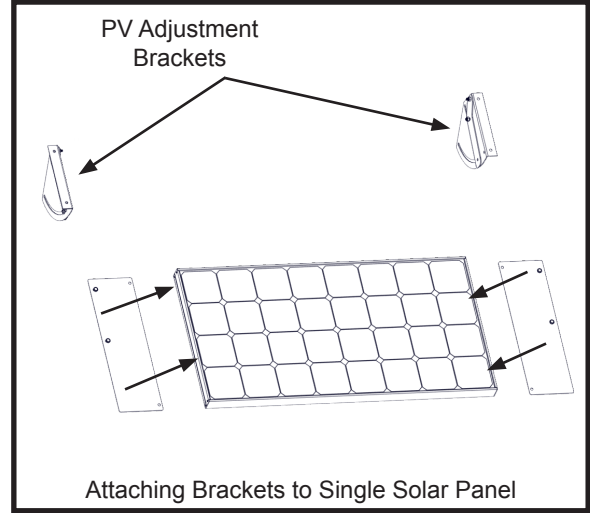

Attaching Brackets to Single Solar Panel

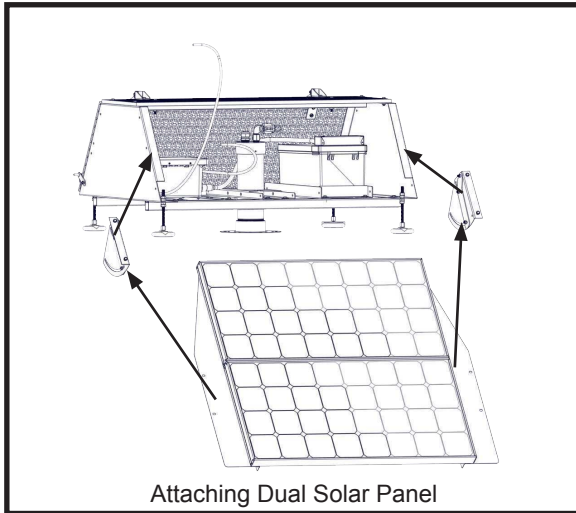

Attaching Dual Solar Panel

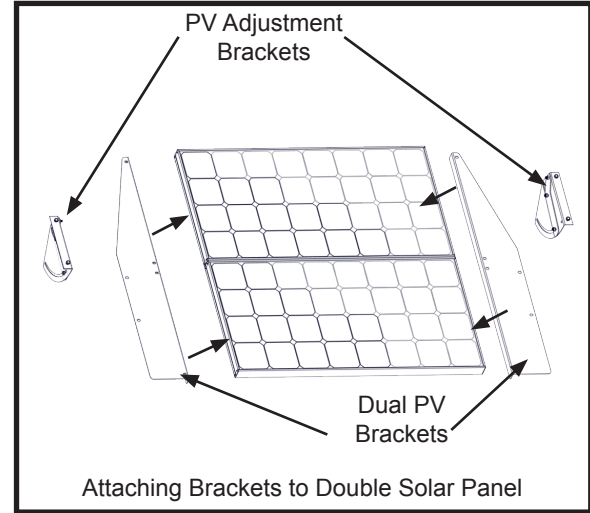

Attaching Brackets to Double Solar Panel

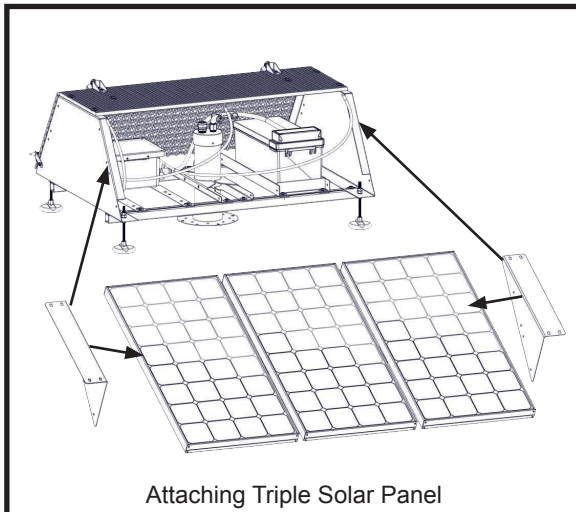

Attaching Triple Solar Panel

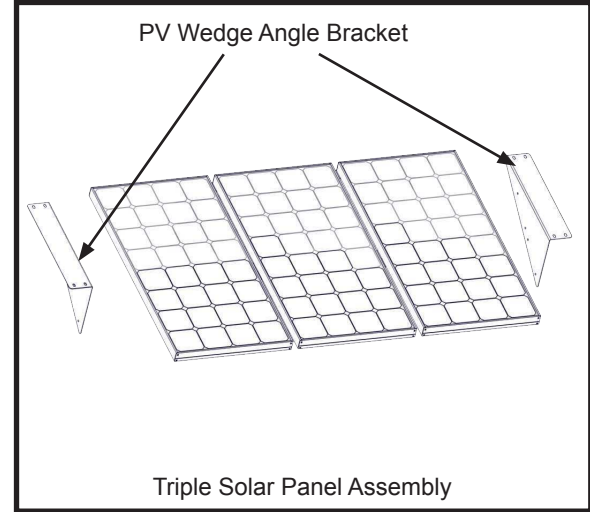

Triple Solar Panel Assembly

Low Profile Stand

Assembly Diagram



Low Profile Stand Assembly

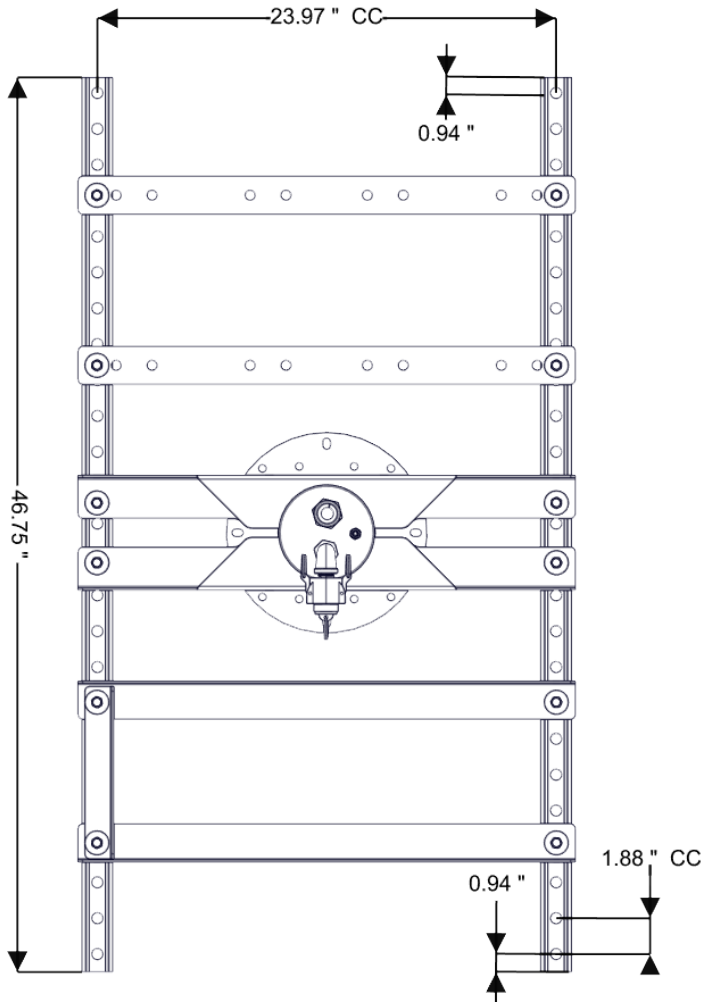
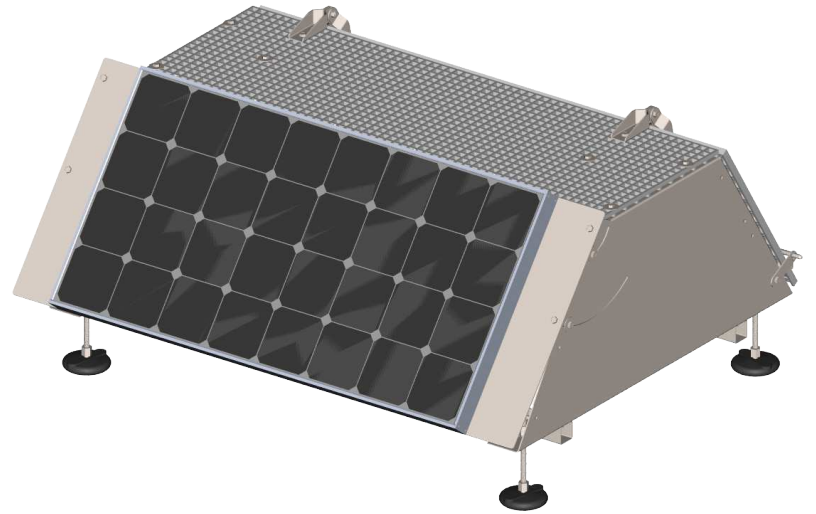

Low Profile Stand

Assembly Diagram

Low Profile Stand Assembly

Panel #1	1 Panel	2 Panel	3 Panel
Approximate Weight	290 lbs	300 lbs	310 lbs
X"	52"	52"	63"
Y"	43"	44"	60"
Z"	24"	41"	27"

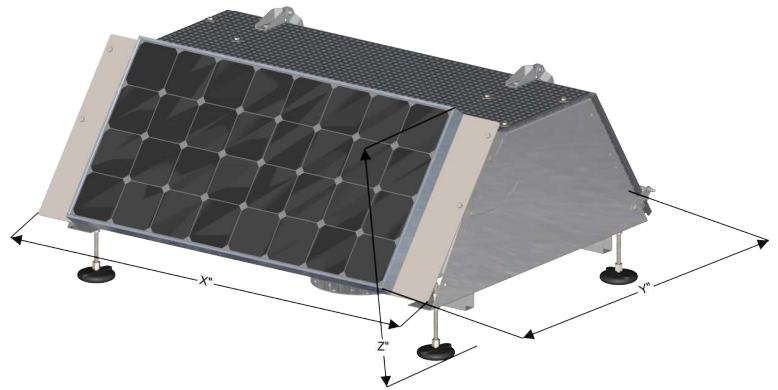
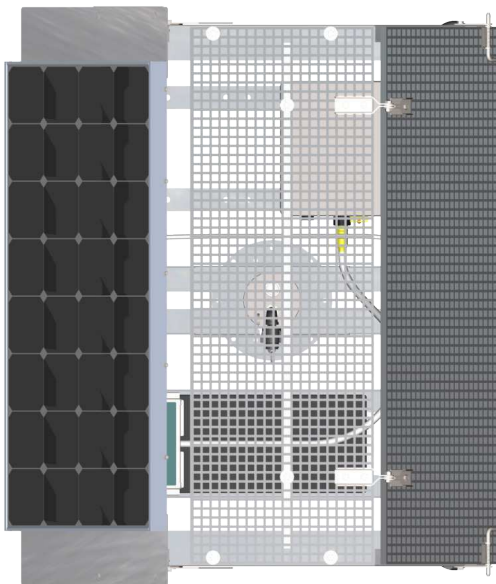

4 Inch Stainless Coupling Detail

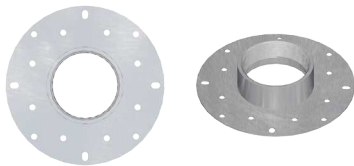

4 Inch Pipe Assembly Detail

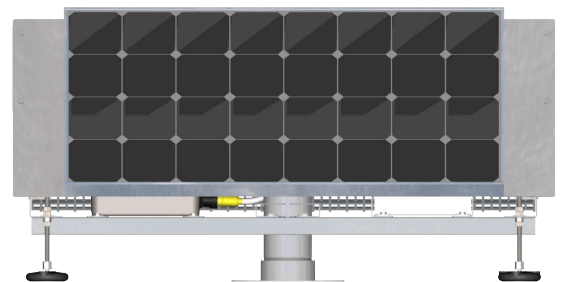
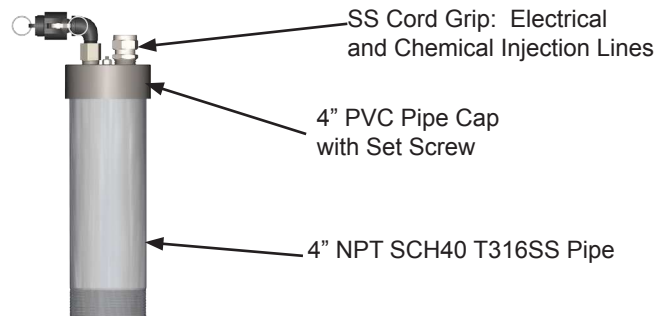

Integration

4" Coupling Flange Assembly For Steel Roof Systems

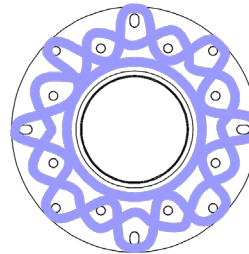
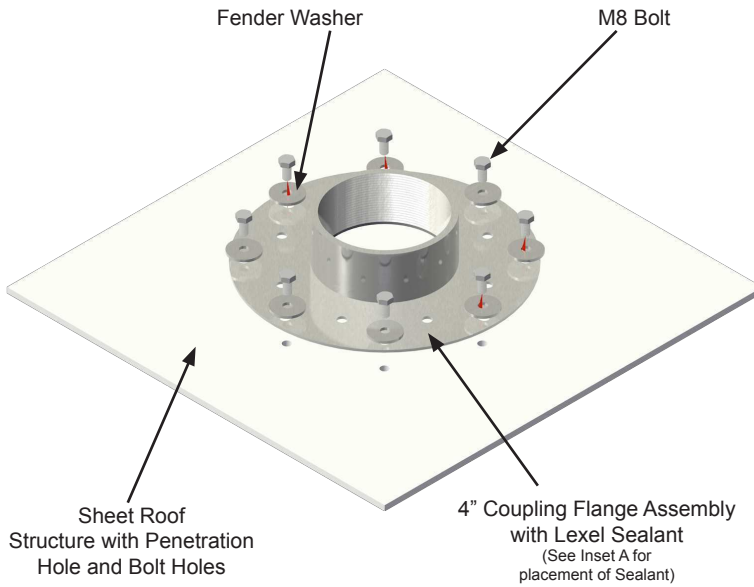

Inset A

Figure 1: Outside Tank Bolt Installation

***** NOT DESIGNED AS A
SUBMERSIBLE PENETRATION *****

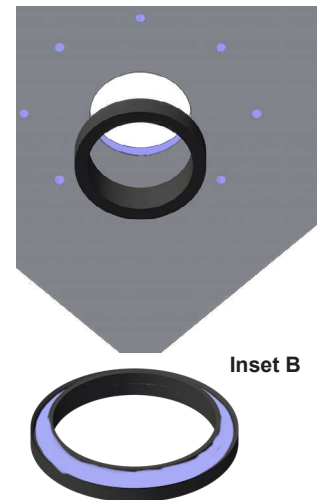
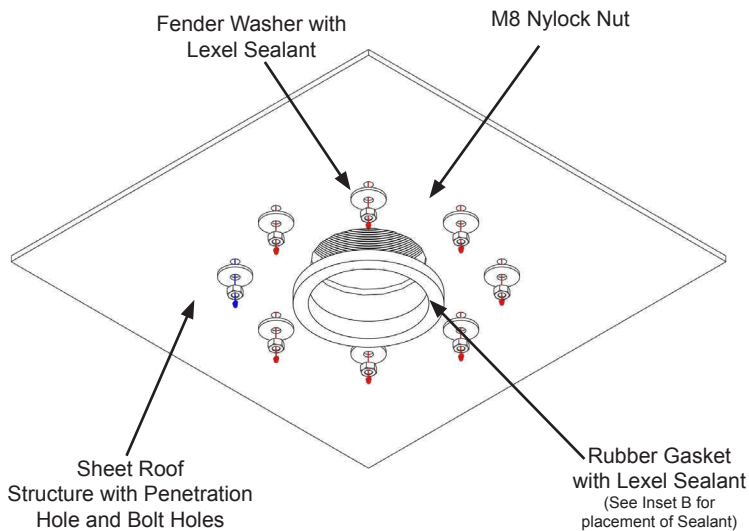

Inset B

Figure 2: Inside Tank Bolt, Gasket and Flange Installation

4" Coupling Flange Assembly

For Steel Roof Systems

T316 SS FLANGE PENETRATION: 4" COUPLING FLANGE ASSEMBLY

TANK PENETRATION IS SEALED WITH
PVC GASKET ACCOMPANIED BY
LEXEL® CO-POLYMER RUBBER-BASED SEALANT

1 FLANGE PER MACHINE:

BOLT PATTERN:	STD 4" 150LB FLANGE STD 6" 150LB FLANGE
GASKET OD:	5.350"
BORE REQUIRED OD:	4.125"
BOLT HOLE OD:	0.346"

Procedural Steps

1. Use Coupling Flange as a template for center hole and at least 6 bolt holes and mark on roof.
2. Make sure to not drill into interior structural beams. Pick a clear location to place the flange.
3. Mark and then cut holes, catch and collect filings.
4. Make sure all holes that have been cut are coated in Lexel sealant.

1 FLANGE PER MACHINE

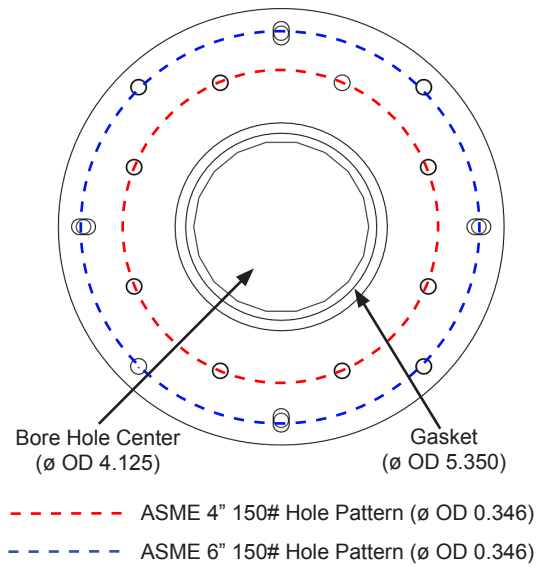

Figure 3: Flange Bolt Pattern Outside Tank

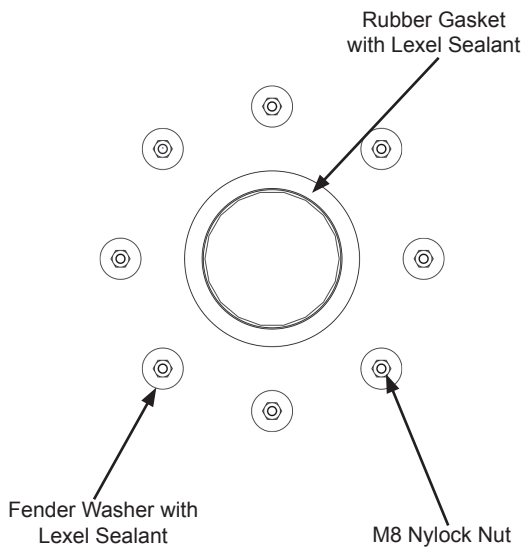
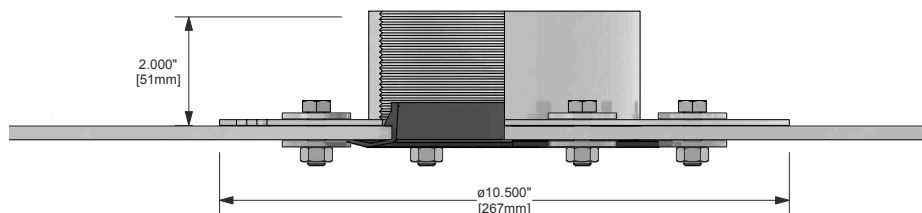

Figure 4: Bolt View Inside Tank

Figure 5: Side Cutaway View of Completed Installation



Features

Features

SB500PWc

The SolarBee with technology includes new features which enhance its performance through more efficient and durable components, improved operation monitoring capabilities, easy component access, and a robust frame structure.

Solar / Electronics

Photovoltaic (PV) Modules -The PV modules are often referred to as the solar panels. The SolarBee uses 100% solar energy to provide day/night operation. The PV modules collect solar power to operate the machine with excess left over to charge an onboard 12-volt, deep cycle battery. The SolarBee has an 80-watt PV modules which individually connect to the digital controller. A bird deterrent is located directly above the PV modules to prevent bird fouling.

The PV module is generally placed on a low profile structure which encloses the controller and battery. The PV module is positioned so it faces the direction of best sunlight.

The low profile solar panel stand offers additional protection by providing shading while also allowing ventilation. Keeping the temperature down inside the digital controller and the battery at a lower temperature which extends the life of the battery and electronics.

Deep Cycle Battery - The deep cycle battery stores excess power from the PV module during the day and operates the machine using the stored power during the night and extremely overcast days.

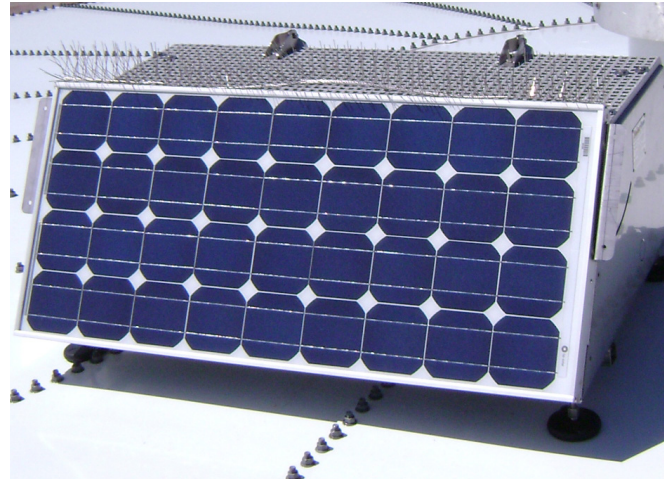

Low Profile Stand



Interior of Low Profile Stand

Features

Features

SB500PWc

Digital Controller - The digital controller is located inside the the low profile solar panel stand. The digital controller operates and monitors the SolarBee. The digital controller is programmed with application specific run schedule, fallback rpm, and battery charge settings. The SolarBee's Design and Application Engineering groups are constantly reviewing the program to optimize operation. The digital controller can be updated with a new program (firmware) using a SD (Secure Digital) Card, similar to that of a digital camera's memory stick.

All solar energy collection and motor operation are managed by the digital controller. This component has two primary functions: (1) To direct and divide the power being collected by the PV module(s) between the brushless motor and battery. (2) To serve as the main control center that operates the brushless motor.

There are 3 PV module connections located on the front face of the digital controller. If the supplemental AC power accessory was purchased, a connection will be located on the right side face. The supplemental power connection is used only in applications where AC grid power is desired.

The left side face of the digital controller contains the brushless motor connection, battery connection, and On/Off switch. The On/Off switch activates power to the motor. When the switch is turned to the Off position, the motor will not operate. The charging function of the controller will continue to charge the battery even when the switch is turned off.

SCADA outputs offering machine operation parameters reside within the digital controller. Please contact SolarBee if you are interested in receiving these parameters.

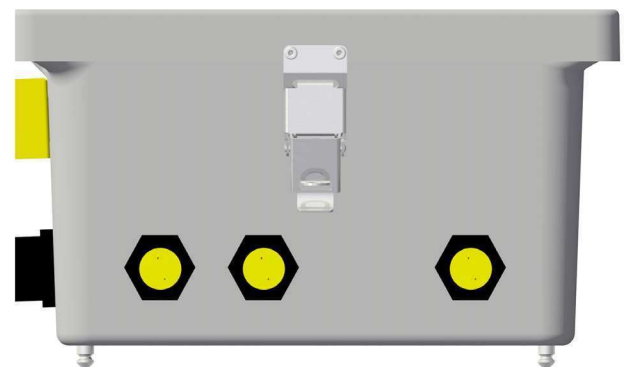

Front Face Of Digital Controller

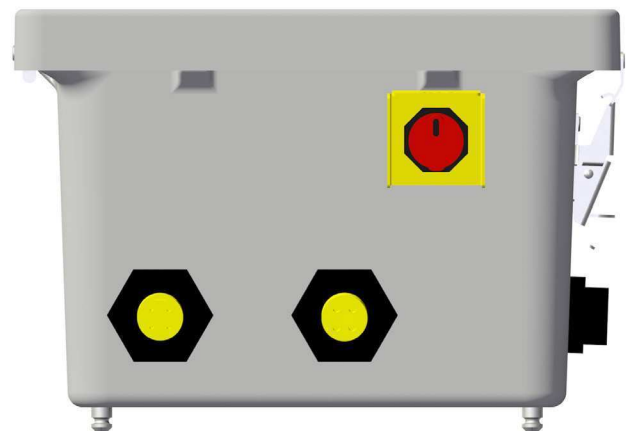

Left Side Face Of Digital Controller

Features

Features

SB500PWc

Motor Controller - The motor controller is located near the motor just below the top plate of the SolarBee. The motor controller is sealed in line with the electrical cord that runs to the brushless motor.

The motor controller on the SolarBee receives power and signals from the digital controller located inside the low profile stand. These signals are used to operate the brushless motor at the commanded speed. The motor controller also sends feedback signals back up to the digital controller.

Due to the high frequency of communication between the motor controller and brushless motor, the two components need to be located close to one another. This is the primary reason for having the motor controller located directly on the SolarBee.

All electronic connections on the SolarBee equipment should only be used for the inputs or outputs that they are labeled and designed for. If any of the leads going into the digital controller are disconnected, be sure when re-connecting to place them in the proper position, following the proper power up/power down procedures.

Wiring - All electric wiring includes corrosion-resistant, industrial cords with molded, weather and watertight connectors. The connectors are indexed to prevent improper wiring. A general electrical schematic can be found in the Maintenance and Field Adjustment section.

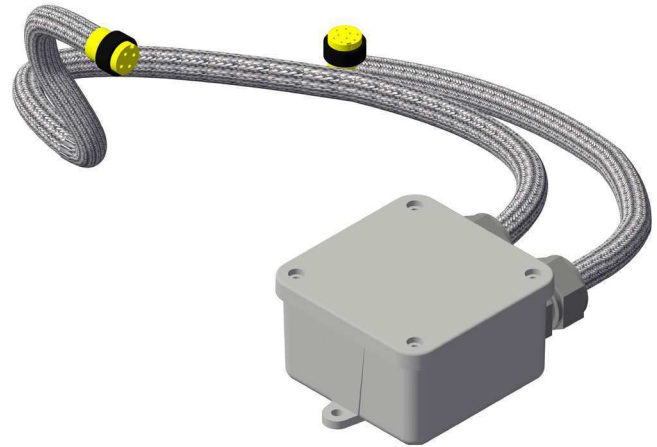

Motor Control Cord

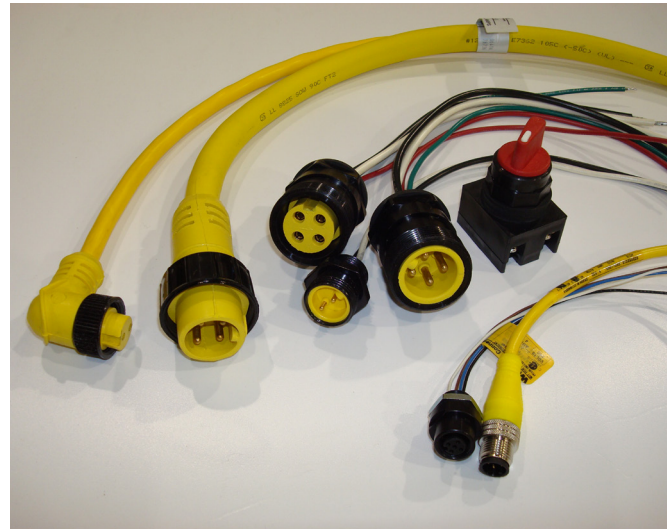

Durable Wiring And Connectors

Features

Features

SB500PWc

Brushless Motor / Impeller

Brushless Motor - The brushless motor is located directly below the Top Deck. 4 bolts run down through the Top Deck and into the housing of the brushless motor fastening it onto the machine.

The brushless motor is built to be very durable. The housing is constructed of casted aluminum. The brushless motor runs very quietly and smoothly. It does not require any maintenance. A drive shaft extends through the bottom center of the housing.

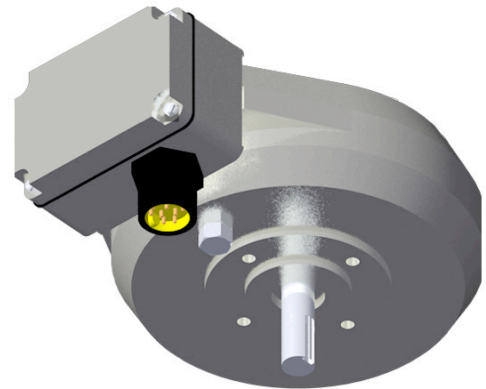

Brushless Motor

Shaft Coupling - The shaft coupling connects the brushless motor drive shaft to the impeller shaft. The shaft coupling is located directly below the brushless motor.

The rotating assembly (motor, shaft coupling, impeller shaft, impeller) can be removed from the machine without disconnecting the shaft coupling.

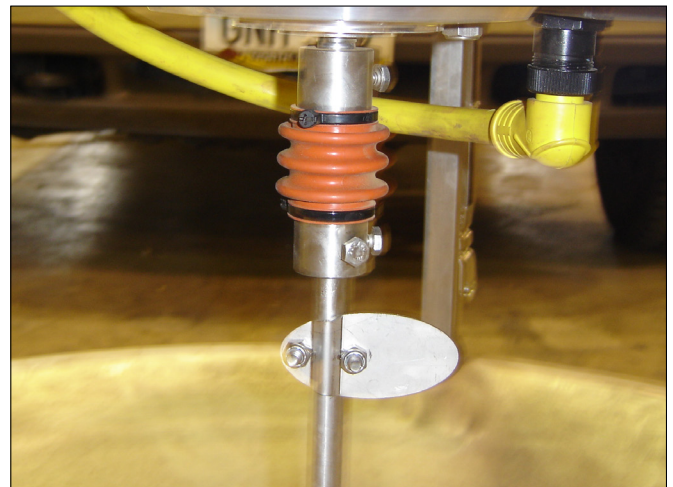

Brushless Motor With Shaft Coupling Attached

Features

Features

SB500PWc

Impeller Assembly - The rotating assembly is made up of the stainless steel impeller shaft, stainless steel flag indicator, and stainless steel impeller blades. The impeller assembly can be removed by pulling on the top plate.



CAUTION: KEEP BODY APPENDAGES OR LOOSE CLOTHING AWAY FROM THE IMPELLER ASSEMBLY WHILE THE MACHINE IS OPERATING! IF MAINTENANCE IS REQUIRED, BE SURE TO TURN THE SOLARBEE OFF FIRST!

The flag indicator is fixed to the shaft and used as a visual indicator of the impeller shaft's rotational speed.

The impeller blades are welded to a hub that is fastened to the impeller shaft. The impeller is designed to gently pump water from below and can handle up to 7.6cm (3-inch) spherical solids.

The impeller bushing is a smooth collar that the impeller shaft tip fits into. The impeller bushing aligns and centers the impeller shaft within the machine.



Turn SolarBee Off Before Performing Maintenance

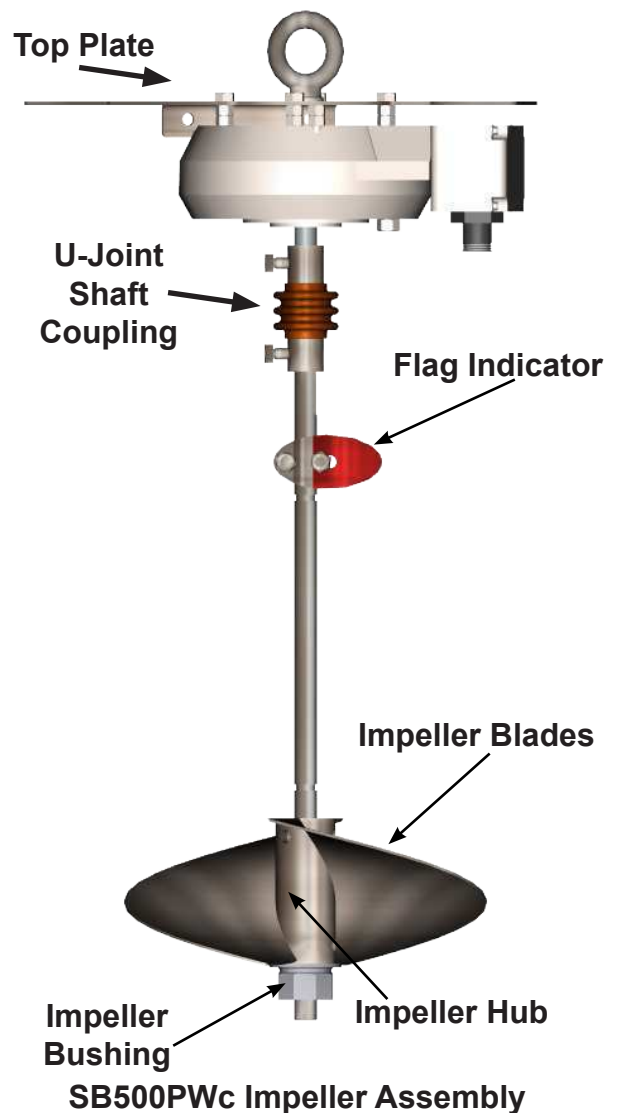

Features

Features

SB500PWc

Distributor Dish / Hose

The distributor dish, structural members, structural fasteners, and mounting brackets are constructed of stainless steel.

Distributor Dish - Near-laminar flow is achieved by the SolarBee due to its uniquely designed distributor dish. The impeller rotates while sitting within the lower half of the distributor dish. The gentle water movement strengthens the induced flow effect (water movement occurring between the lower water layer entering the machine and the upper water layer leaving the dish).

The top lip of the distributor dish is set approximately 1-1/2 inch to 2-inch (3.8cm - 5.0 cm) below the surface of the water to achieve best flow results. The distributor dish depth is set at the factory and should not need adjustment after deployment.

Hose - The hose extends from below the dish down to the floor of the reservoir. The intake level is generally set just above the floor of the reservoir. As the water level fluctuates, the hose remains at a fixed placement on the reservoir floor by the use of a torque bar as the extra hose lays on the bottom. The intake draws water horizontally into the hose.

The contact between the torque bar and the floor prevents the machine from rotating or moving out of place. The machine naturally has a very small torque due to impeller rotation.



Distributor Dish



**Hose With Bend Keeping
Position Stationary**

Features

Features

SB500PWc

Float Arm / Floats

The SolarBee contains 3 float assemblies. The float arm allows vertical positioning of the machine and the floats provide buoyancy.

Floats - The float is made from high density Polyethylene. The floats are filled with a Polystyrene closed-cell foam for long term buoyancy. The stainless steel float arm is attached to the float resting in a channel molded into the float. The float arm connects the float to the core unit of the SolarBee. The float is shaped to hug the hose for installation purposes allowing the machine to be installed in a 18" diameter hatch. The floats have a uniquely designed shape to:

- Minimize space when collapsed around the hose.
- Minimize the interference with the water flow on the surface coming off the distributor dish.

Float Arm - The float arms are constructed of stainless steel. They directly connect the floats to the central machine structure. The end of the float arm contacts the core unit frame structure to allow for a horizontal float deployment.



Float

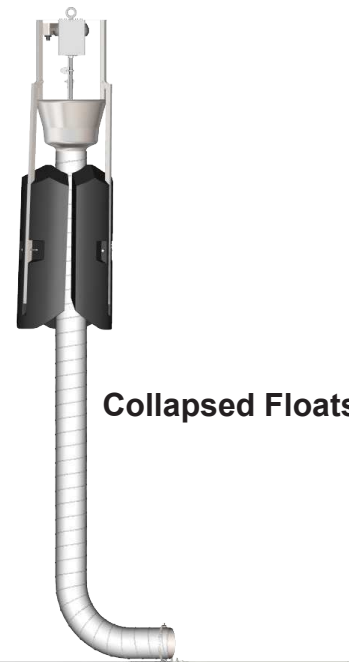

Collapsed Floats

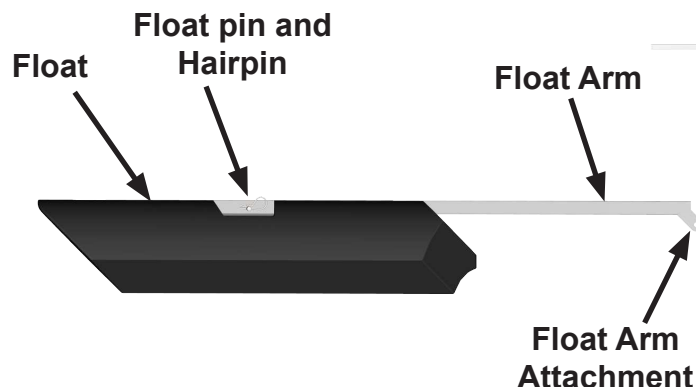

Features

Features

SB500PWc

Float Assembly - The float assembly connects to the core unit in one location. There is no adjustment necessary for setting the dish depth.

The float assembly is bolted to the core unit of the SolarBee to allow the distributor dish lip to be automatically set to the correct depth below the surface of the water. The depth may vary depending on hose length being supported by the machine and the amount of hose resting on the bottom of the reservoir due to fluctuations of the water.

Each float arm is connected to the central machine structure with 1 bolt. Each float is connected to the float arm by one float pin. Each float assembly is constructed of the molded float and float arm. The end of the float arm contacts the core unit frame when the float is extended into place by means of buoyancy pressure when deployed into the water.

If the machine is resting in the bottom of an empty tank, the SolarBee will be supported against the floats resting on the floor of the tank. Once water is brought back into the tank, the machine will self deploy and begin to float.

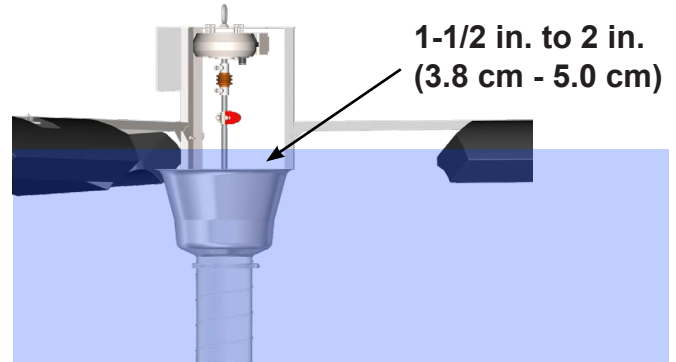

Distance Between Distributor Dish And Water Level

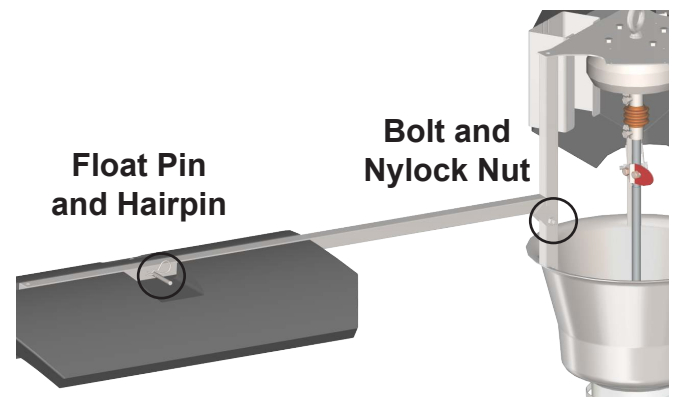

Float Connection Points

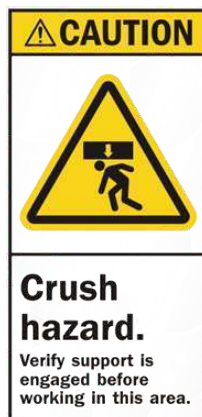

CAUTION: DO NOT REMOVE ANY FLOAT ASSEMBLY PINS OR BOLTS WHILE THE SOLARBEE IS FLOATING IN THE WATER! THE SOLARBEE MUST BE RESTING ON THE GROUND OR SAFELY SUPPORTED TO RELIEVE THE FORCES ON THE FLOAT ASSEMBLY STRUCTURES PRIOR TO DISASSEMBLY! FAILURE TO FOLLOW THIS WARNING COULD LEAD TO SINKING THE SOLARBEE, SERIOUS INJURY!

Tethering

Visual Dual Tethering

Small Frame SN and SB

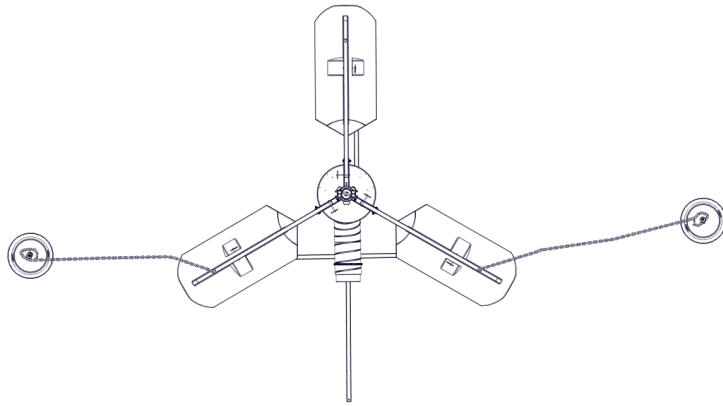

TOP VIEW SN DUAL TETHERING

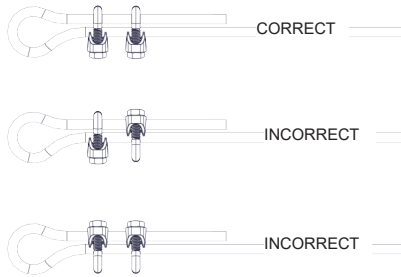

CABLE CLAMP DETAIL

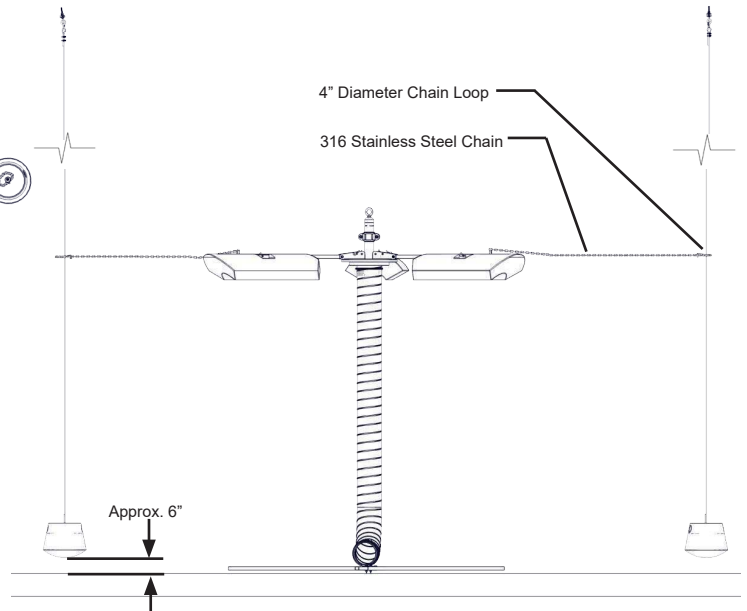

FRONT VIEW SN DUAL TETHERING

CONCRETE ROOF

* Anchor provided by Contractor / Tank Manufacturer

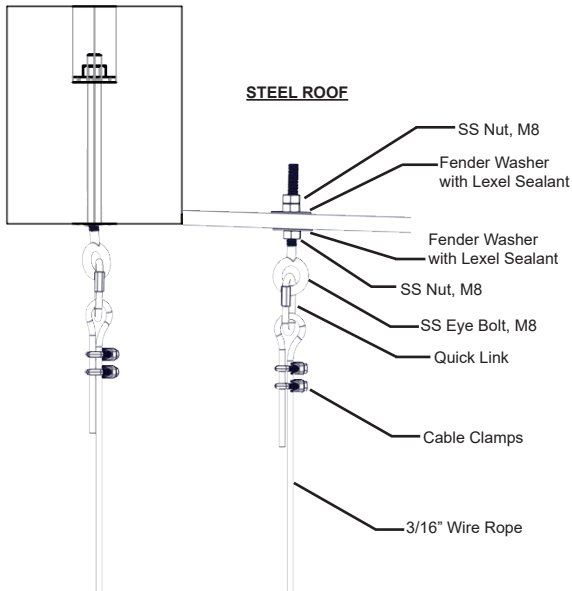

ROOF CONNECTION DETAIL

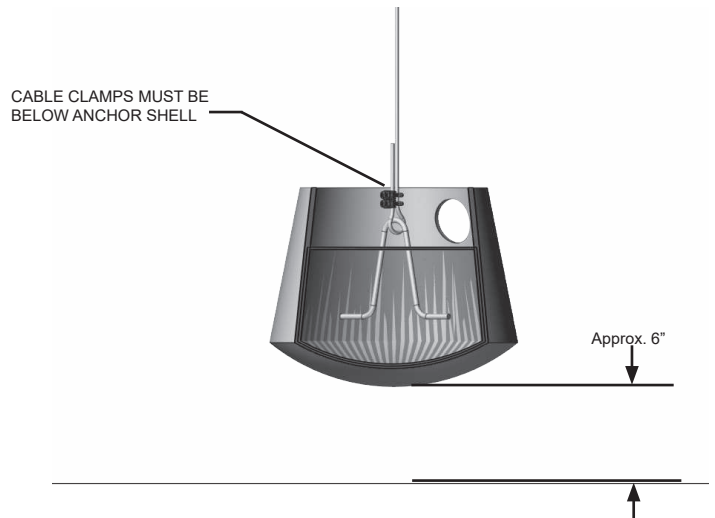

MOORING BLOCK CONNECTION DETAIL

Maintenance

Maintenance and Field Adjustment

SB / GF PW Series Mixers

The performance of the Machine has proven to increase tremendously when its operator understands the operation of the machine and knows how to carry out field adjustment procedures.

In most cases, the operator have can perform routine checkups and field adjustment procedures on the Machine, by pulling the Machine to the hatch. A large, expensive boat isn't necessary. When tank entry is required, an inflatable raft/boat (approximately 6 ft) is deployed inside the tank.

It is extremely important that safety comes first every time the Machine is inspected or having maintenance procedures performed. It is strongly encouraged that anyone working on or near the machine follow these rules:



⚠️ Wear a personal floatation device

⚠️ Stay focused and alert

⚠️ Turn the Machine off before working on it

⚠️ Stay clear of parts while they are moving

To turn the Machine motor off, turn the On / Off switch to the off position. To completely power down the digital controller, remove all power sources in the proper sequence.

SAFETY FIRST

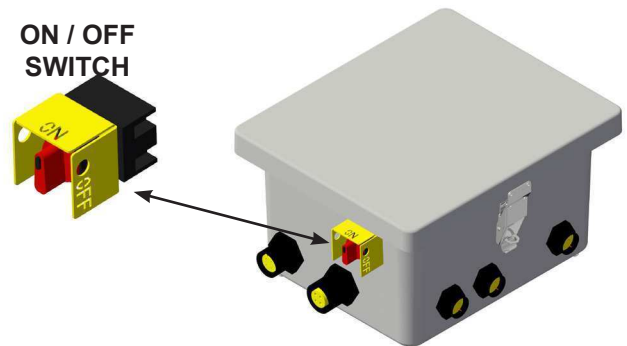

**DIGITAL
CONTROLLER**

Maintenance

Rigging Points

SB / GF Series Small Frame Mixers

Under some circumstances, it may be necessary for the customer to remove or transport the machine from the reservoir. For potable water applications, Ixom strongly encourages the customer to consult with our Customer Support Team before attempting to remove a potable water machine. The machine is designed to be suspended by three points that are reinforced.

Rigging may need to be made up to allow connection to all three rigging points. The design calls for all three points to be used in order to support the weight of the machine and keep it balanced once suspended.

MODEL MAY VARY

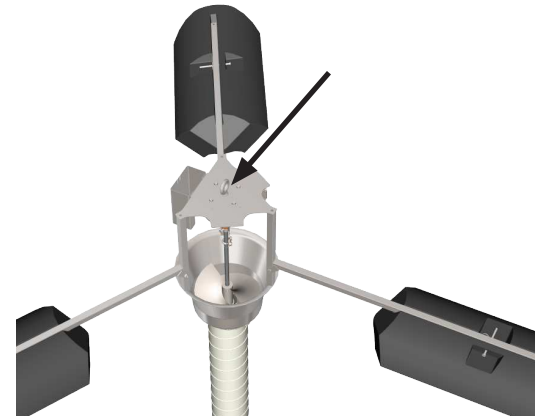

500PWc



1250PWc



Large Frame Machines



CAUTION: DO NOT REMOVE ANY FLOAT ASSEMBLY PINS OR BOLTS WHILE THE MACHINE IS FLOATING IN THE WATER! THE MACHINE MUST BE RESTING ON THE GROUND OR SAFELY SUPPORTED TO RELIEVE THE FORCES ON THE FLOAT ASSEMBLY STRUCTURES PRIOR TO DISASSEMBLY! FAILURE TO FOLLOW THIS WARNING COULD LEAD TO SINKING THE MACHINE, OR CAUSE SERIOUS INJURY!



Maintenance

Small Frame Dish Levels

SB / GF Series Small Frame Mixers

Distribution Dish Level Setting

The machine distributor dish depth in the water is a key factor in maintaining the near-laminar flow of water coming off the machine.

The distribution dish level setting is measured from the top lip of the dish up to the water surface. For the Small Frame machine, set the depth level according to the following table:

Model	Depth - Inch	Depth - cm
500PWc	1 1/2 - 2	3.8 - 5.0
1250PWc	3/4 - 1	2.0 - 2.5

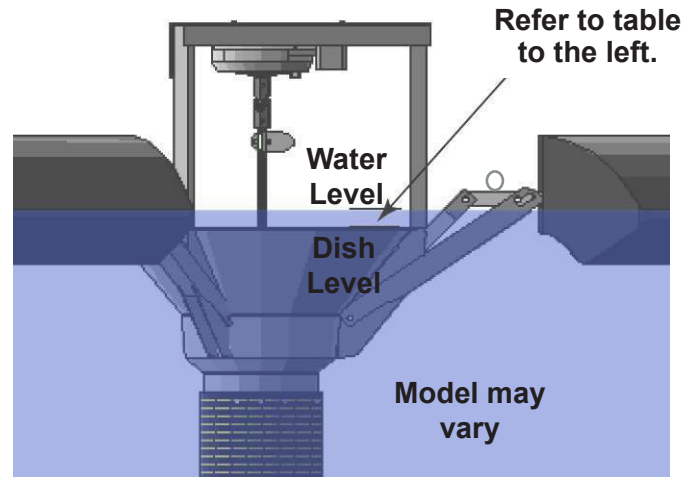

Distance Between Distributor Dish And Water Level

Distribution Dish Level Adjustment

TOOLS RECOMMENDED:

No tools are necessary.

The collapsible machine model was designed specially for potable tanks and reservoirs where the hatch size is too small for confined space entry. Therefore, the float assembly were designed to set the machine in the correct depth of water when the machine is deployed.

There are no adjustments that needed for setting the dish depth. After the reservoir has been drained and refilled, the machine will automatically redeploy itself. It is a good idea to visually check the machine to confirm that the machine had properly deployed itself in the case of the tank being drained and refilled.

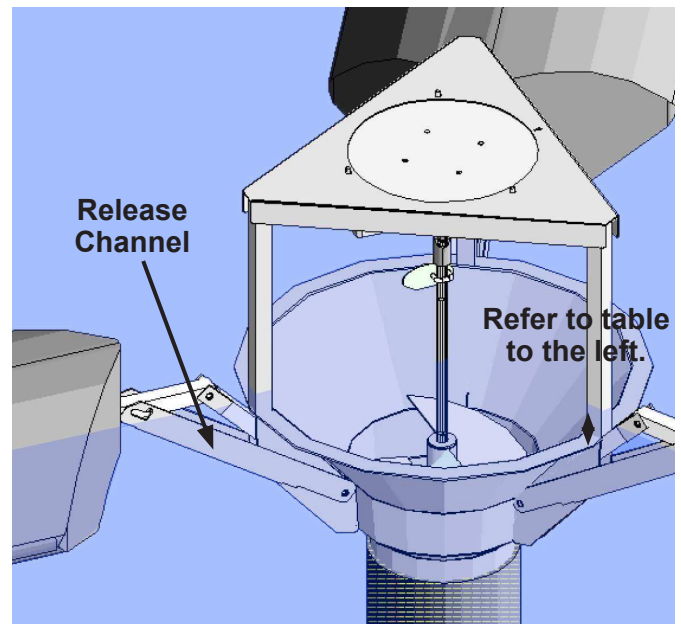

Water Level Refer to table upper left.

Maintenance

PV Module Cleaning

SB Series Mixers

The solar panels are the SolarBee's primary source of energy, so it is important that they be kept clean. Over time, dust collects on the PV modules or birds are not kept completely off by the bird deterrent resulting in the panel's effective surface area decreasing.

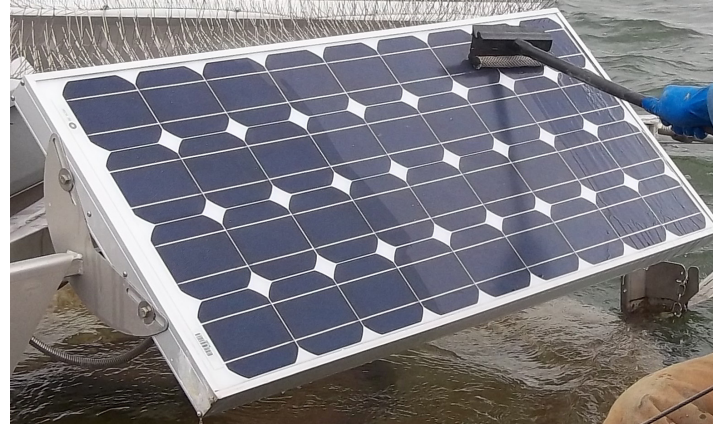

(If Equipped the following applies)

The SolarBee controller and solar panel(s) are generally located on the roof of the tank or reservoir. If your tank is ground storage standpipe, hydropillar, pedesphere, or other style elevated tank, please follow the necessary OSHA regulations in regards to Fall Protection, Rescue, etc.



TOOLS RECOMMENDED:

Squeegee
Glass Cleaner
Paper Towel or Wash Cloth

STEP 1: Rinse panel face off with water.

STEP 2: Use squeegee, towel, or wash cloth to clean surface of panel.

STEP 3: Remove any streaks or films using glass cleaner and paper towel/wash cloth.

STEP 4: Repeat Steps 1 through 3 for each solar panel.



Maintenance

RPM Check

SB/GF Series

Impeller Rotational Speed Check

During clear skies and good sunlight weather conditions, the drive system of the unit should operate:

- 1) At a rotational speed between 55 and 85 revolutions per minute (rpm).
- 2) In a clockwise direction when looking down at the impeller.

Checking Rotational Speed

TOOLS RECOMMENDED:

Watch or Stopwatch

STEP 1: Locate the flag indicator on the impeller shaft.

STEP 2: Start the stopwatch or mark a starting point on the watch. Immediately begin counting each full revolution of the flag indicator (starting with "ZERO", "ONE", "TWO", etc) for a time of less than or equal to 1 minute and at least 20 seconds. This step is easier with two people, one counting revolutions and the other keeping track of the time expired.

STEP 3: Quit counting revolutions and immediately observe how much time has expired in seconds.

STEP 4: Use the following equation to calculate rotational speed in rpms:

$$\text{Revolutions Per Minute (RPM)} = \frac{(\# \text{ Revolutions Counted} \times 60)}{\# \text{ Seconds Expired}}$$

MODEL MAY VARY

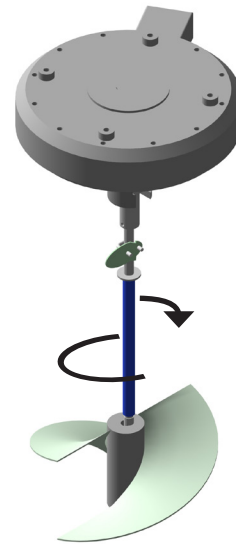

Clockwise Rotation When Looking Down

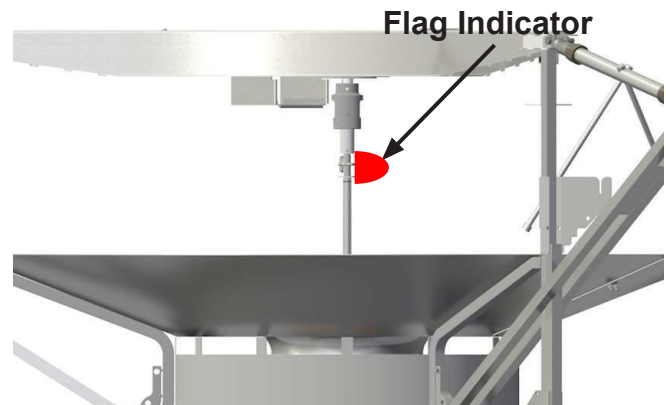

Flag Indicator Section of Impeller Shaft

Example: 30 Revolutions were counted in a time period of 30 seconds.

$$\text{RPM} = (30 \text{ revolutions} \times 60) / (30 \text{ seconds}) = 60$$

Impeller Rotational Speed = 60 RPMs

Maintenance

Impeller Assembly Removal

SB / GF Series Small Frame Mixers

Impeller Assembly Removal

In the case that there is buildup below the impeller that cannot be reached, the impeller assembly can easily be removed.

TOOLS RECOMMENDED:

Elbow High Rubber Gloves
Garbage Bag



STEP 1: With machine off locate the 3 fasteners on the top plate that attach it to the frame and remove them.

STEP 2: Firmly grasp the top plate and pull straight up on the impeller assembly.

STEP 3: Observe and clean any debris located on the bottom of the impeller.

STEP 4: Observe and clean any debris located down in the dish where the impeller rests. Place the debris into a garbage bag and remove from pond to prevent it from going through machine again. **Follow all local laws and regulations when disposing of any materials collected.**

STEP 5: Once clean, place impeller assembly back in place. Be sure bottom of impeller shaft fits into the bushing in the dish and that the 3 top plate holes are aligned with the top of the frame.

STEP 6: Replace the 3 fasteners that were removed in Step 1.

STEP 7: Turn machine back on.

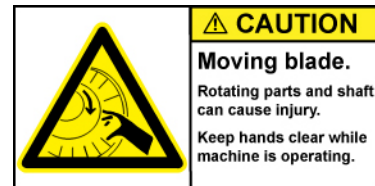

Turn Machine Off Before Performing Maintenance

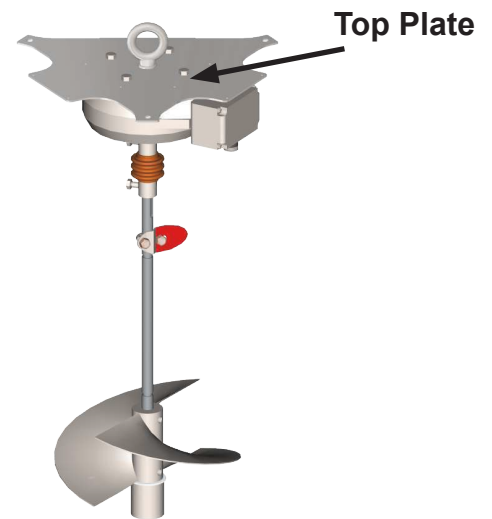

500PWc Impeller Assembly

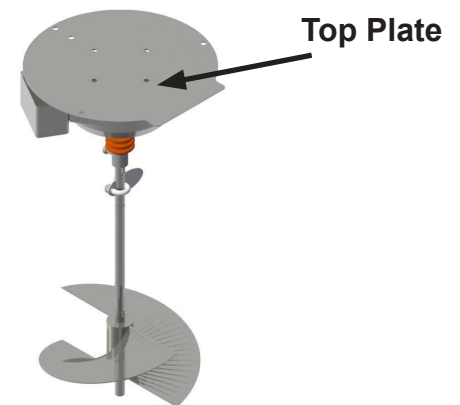

1250PWc Impeller Assembly



CAUTION: TURN MACHINE OFF BEFORE WORKING NEAR IMPELLER! WEAR PROTECTIVE GLOVES AND BE CAUTIOUS OF SHARP LEADING EDGES ON IMPELLER BLADES WHILE CLEANING! FAILURE TO FOLLOW THESE WARNINGS COULD LEAD TO INJURY!

Maintenance

Battery Replacement

SB Series Potable Water

Battery Replacement

The SolarBee contains an onboard battery located in the electronic controller that will require infrequent replacement. Between 2 and 3 replacements are expected over the course of the machine life.

TOOLS RECOMMENDED:

NO TOOLS REQUIRED:

STEP 1: Open the solar panel stand access panel located opposite side of the solar panel.

STEP 2: Locate the electronic controller and the On/Off switch. Turn the switch to the "OFF" position.

STEP 3: Refer to proper Power Down Procedure located in the Electrical Section.

STEP 4: With the SolarBee off, unscrew the battery lead from the battery terminal.

STEP 5: Slide the battery out of the panel stand box.

IMPORTANT NOTE:
The battery weighs approximately 140 lbs and may require two people to handle.

STEP 5: Install new battery into position and connect battery lead back up to the battery terminal.

STEP 6: Refer to the proper Power Up Procedure located in the Electrical Section.

STEP 7: Turn the On/Off switch back to the "ON" position.

STEP 8: Be sure the SolarBee is operating correctly and close the access panel.

**** Failure to follow these steps could result in component damage. ****



Battery

Electronic Controller

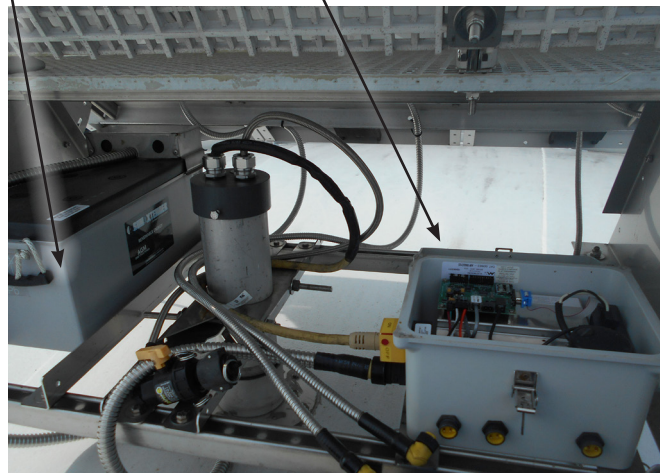

Solar Panel Stand Open With
Controller And Battery

Battery Disposal: Be sure to follow local law and regulations when disposing of the used up battery!

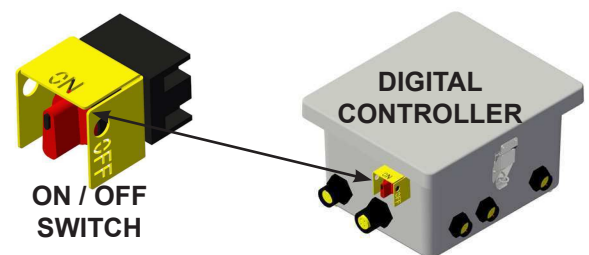

Maintenance

Tank Maintenance

SB / GF Series Mixers, Potable Water

Tank Maintenance

The machine is designed to rest on the floor of the tank in an event when the tank is drained. If the machine is left undisturbed, the machine will naturally float and self adjust when the tank is refilled.

During the event that a potable water tank is taken off-line for maintenance for re-coating, sandblasting, or cleaning, a few considerations need to be followed for the care of the machine. The best solution for the care of the machine is to remove the unit from the tank until the maintenance is complete. Often times there is an access hatch thru the side of a tank which the machine in most cases can easily be removed. Sometimes this is not an option and the following guidelines should be followed in the event of interior tank work.

STEP 1: Turn the machine circulation equipment "Off" if the tank is projected to be dry for more than a few days. The On/Off switch is located in the machine electronic controller mounted to the pv module stand.

STEP 2: Cover the entire machine, including the hose and intake assembly, using a heavy duty tarp. Be sure to tuck the tarp under the machine to avoid any sand being collected on the machine in the case of sandblasting.

STEP 3: The electrical cord and chemical injection cord will be suspended from the ceiling so extreme care needs to be taken to prevent damage to the cord and hose from any abrasions from blasting. Both injection and electrical may be disconnected and coiled up under the tarp if desired.

STEP 4: Once the maintenance is complete, remove the tarp and reconnect the electrical cord and chemical injection hose (if applicable). The machine may need to be cleaned from any dust or sand that may have made it's way thru the tarp. A key component that should be checked and cleaned is the impeller bushing and impeller tip. Please follow the proper procedure earlier in this section.

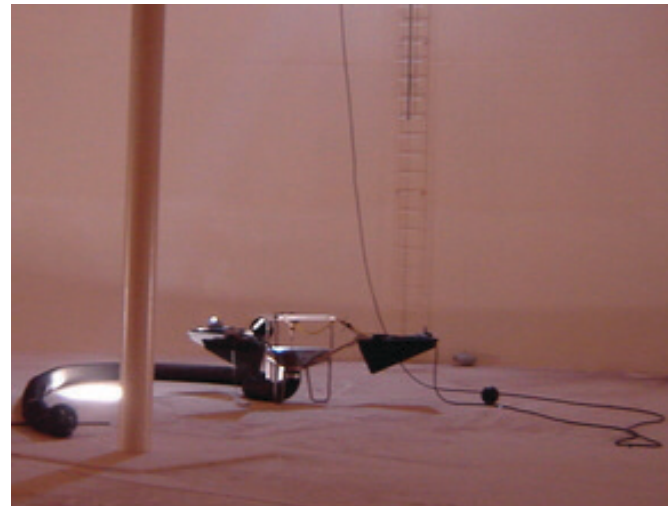

Machine power cord laying tangle free.



Machine resting on floor ready for water.

Maintenance

Tank Maintenance

SB / GF Series Mixers, Potable Water

Tank Maintenance continued,

STEP 5: Decontaminate the machine by wiping all machine surfaces using a bleach/water solution and a towel or cloth. Remove all excess dust, sand, etc. **Do not use a pressure washer to clean the machine.** This may damage the on-board electronics which may result in improper operation of the machine.

STEP 6: The machine intake needs to be placed in its original position and the entire hose layed out across the floor. *The hose should not be coiled or draped over the machine!* Reposition the electrical cord and injection hose so they do not get tangled on any objects.

STEP 7: The machine is now ready for the tank to be filled with water and be turned "On".

Most customers feel that removing the machine circulation equipment is the best option for the safety of the equipment. Removing the equipment also allows for the contractors to perform their work freely and not have to maneuver around the machine.

Please contact Ixom Customer Service:
1-866-437-8076 (customerservice@ixom.com), for a quote for temporary removal of your machine.



Machine resting in drained tank.

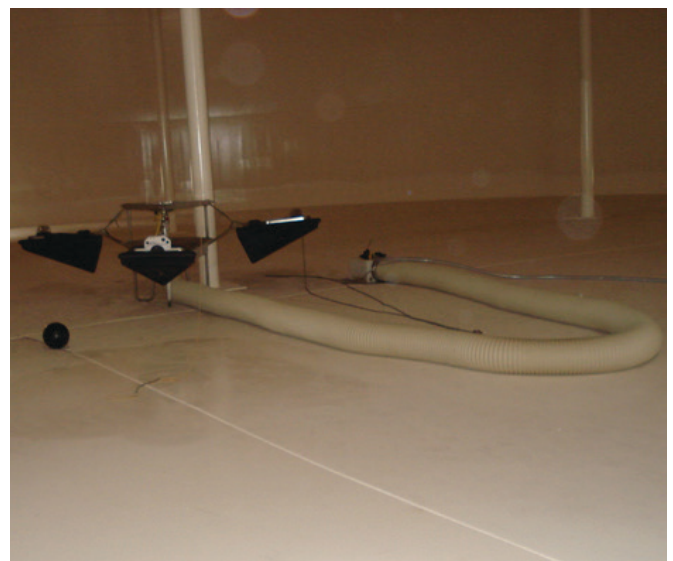

Hose properly layed out on tank floor.





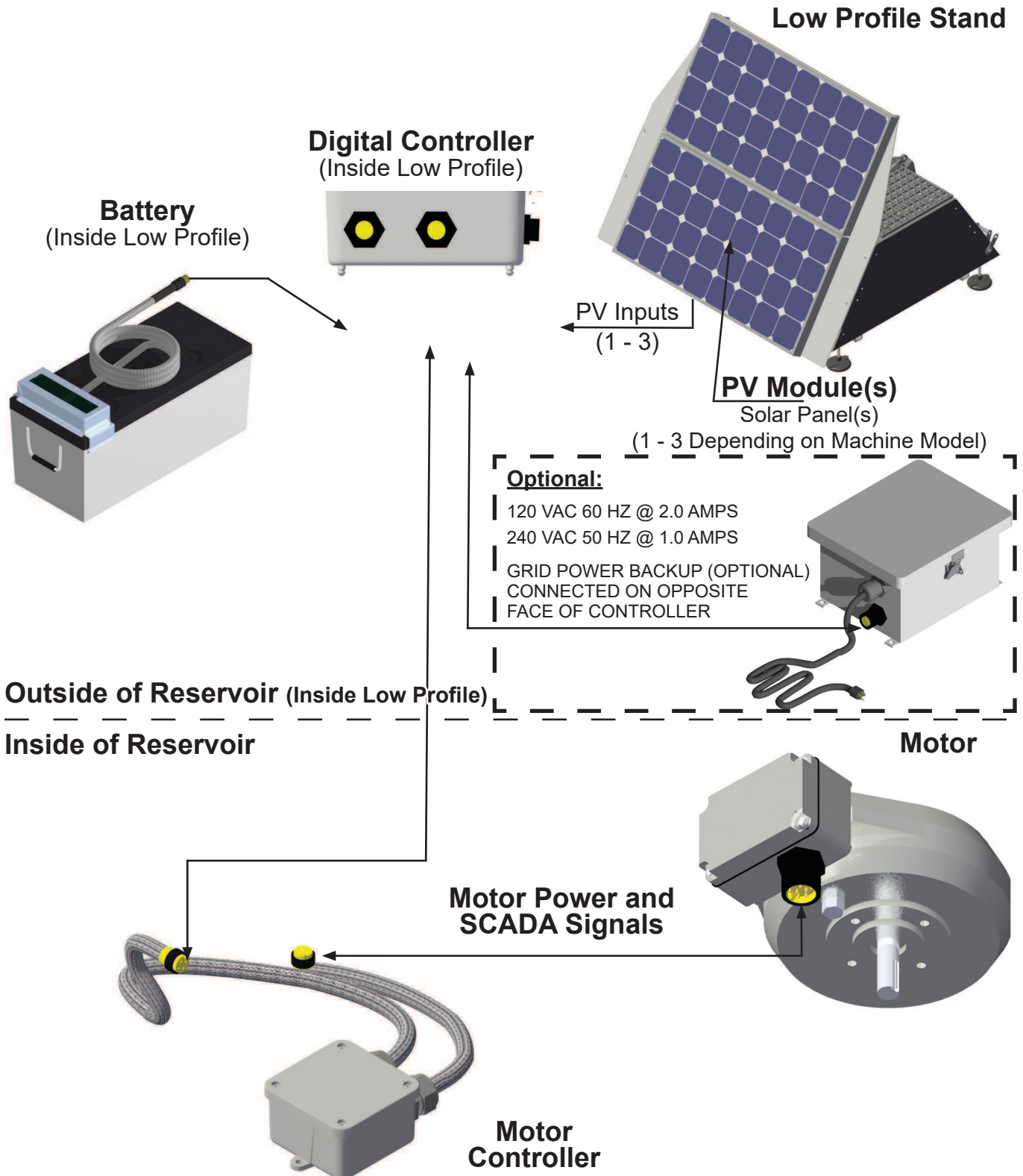







General Electric Overview for Potable Water SolarBee

(Low Profile)



SolarBee/GridBee SD Card

Update Instructions

Insert the SD card into the slot. The solid blue light beside the slot will come on.	 SD CARD INSERTED
Once the correct files have been found, the green light will begin to flash rapidly.	 FILE SEARCH AND DOWNLOAD
When it is time to remove the card, the green and yellow lights will flash rapidly and be alternating. Remove the SD card from the slot.	 DOWNLOAD COMPLETE REMOVE SD CARD
When the card is removed, the red light will flash rapidly. This is the beginning of the self programming with instructions received from the SD card. After the red light is finished, the yellow light will flash rapidly, followed by the green light.	   INITIALIZING PROGRAM
Upon completion the brainboard will restart and perform a system check. Following a successful update the red light blinking once followed by one yellow blink and one green. If you miss this or are unsure, you can repeat the previous steps	   SD CARD UPDATE SUCCESSFUL
If the update was not successful, the red, yellow, and green lights will blink together 10 times. The machine will revert to the default parameters. Insert the card to attempt the update again. If it still fails, contact Customer Service.	   UNSUCCESSFUL SD CARD UPDATE

Please refer to the provided owners manual for normal operation led blink codes.

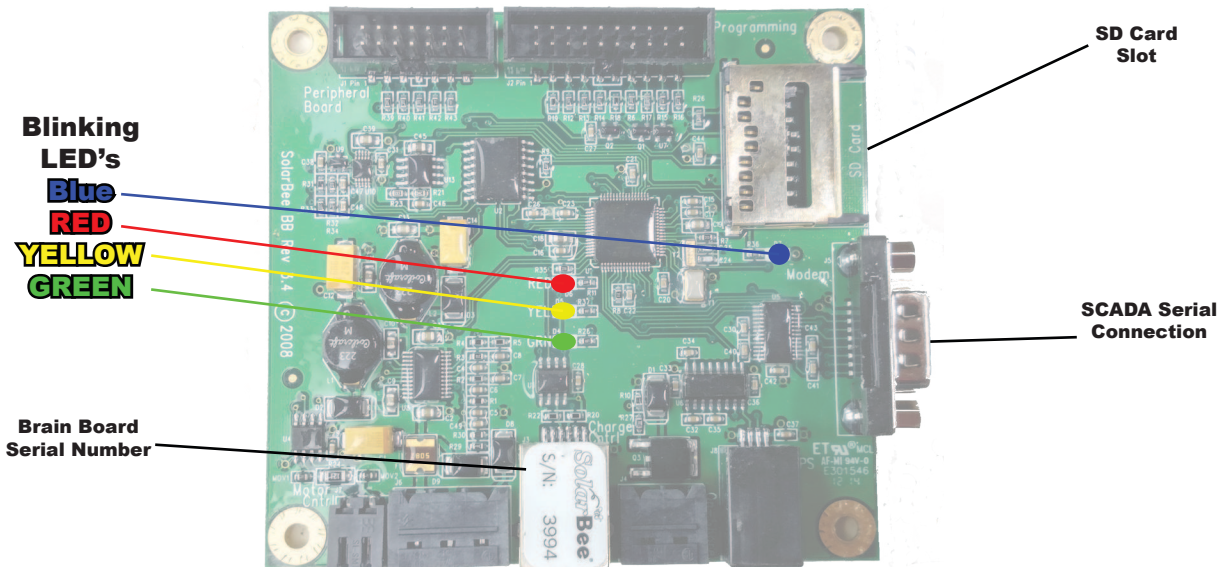

Figure 1: Brainboard

Electrical

Power Down / Power Up Procedure

SB Series

Complete Power Down Procedure

NO TOOLS REQUIRED:

STEP 1: Turn the On/Off switch to Off position.

STEP 2: Unscrew all PV module leads on the front side of the digital controller.

STEP 3: Unscrew the on-shore (grid power) connection on the right face, if applicable.

STEP 4: Disconnect the battery lead on the left face. Now all power is taken away from the electrical system.

Be certain steps 1-4 have been completed before continuing. If this order is not followed, component damage may occur.

STEP 5 & 6: Disconnect the motor controller from the digital controller and from the motor if needed.

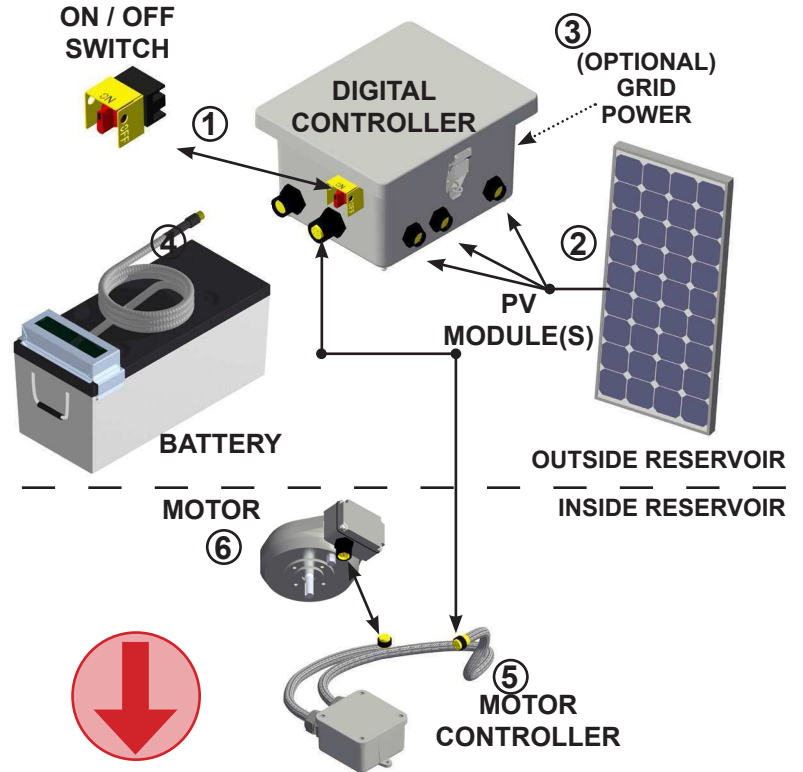

Complete Power Up Procedure

NO TOOLS REQUIRED:

STEP 1 & 2: Connect the motor controller to the motor and to the digital controller.

Be certain steps 1-2 have been completed before continuing. If this order is not followed, component damage may occur.

STEP 3: Now you are able to bring power to boot up the system by plugging in the 4P Male connector of the battery to the left face of the digital controller.

STEP 4: If applicable, connect the on-shore (grid power) 2P male connection to the right side of the digital controller.

STEP 5: Connect all available PV module leads into the front face of the digital controller.

STEP 6: Turn the On/Off switch to On position.

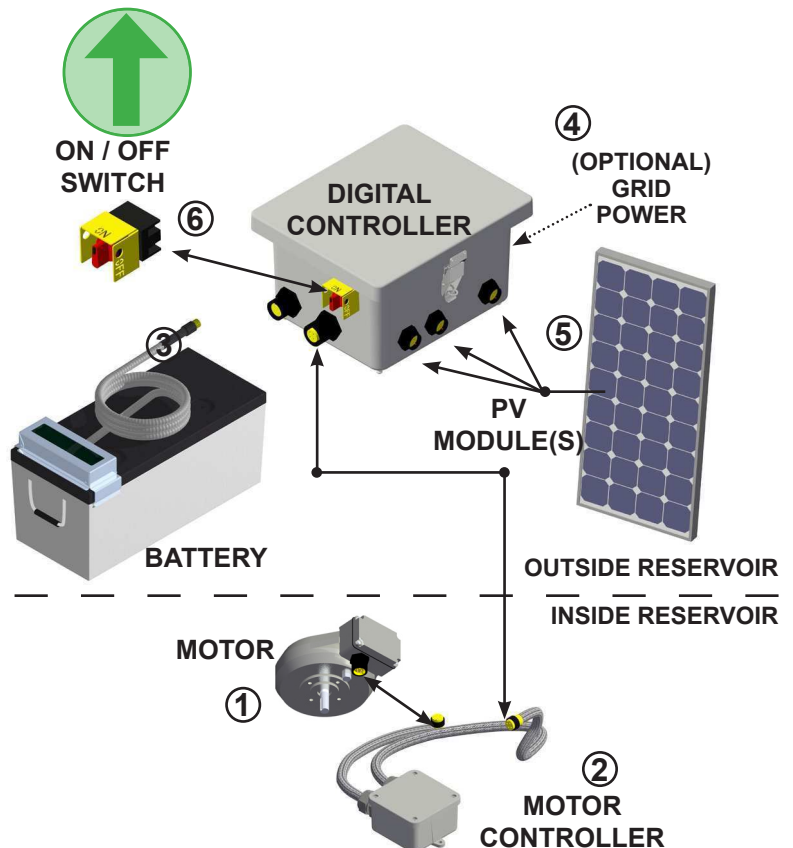

Troubleshooting

Troubleshooting

SB Series

If you find that the SolarBee has quit operating, the following checks can be performed:

Connection Check -

- 1) Locate the digital controller and be sure that each PV module cord is properly connected.
- 2) Check that the battery is properly connected.
- 3) Follow each cord from the electronic controller to its originating component and be sure it is not damaged.

Visual Digital Controller Check - The

SolarBee contains an LED (Light Emitting Diode) blink sequence that indicates the machine operation status. The blinking LEDs are found on the Brain-board located inside the digital controller. A solid green LED is also located on the Zahn board. To observe the LEDs,

- 1) Open the door of the digital controller and locate the laminated LED label on the inside of the door.
- 2) Using the LED label, locate the Brain-board and the Zahn board. Observe and record the blinking LEDs (color and # of blinks in succession) and solid green LED (off or on).
- 3) Using the LED label, match your blink observations to the corresponding indication. Use the information on the next two pages to proceed.

DC Voltage Check -

If a DC voltmeter is available, the battery voltage can be measured off of the brainboard at the 3-pin connection (white, black, and orange leads).

- 1) Using the voltmeter positive lead on the white screw terminal and voltmeter negative lead on the black screw terminal, the voltage can be measured.
- 2) Record the measurement.

SCADA Information - SolarBee operation status information can be transmitted from the machine to a nearby monitoring station by using one of SolarBee's various SCADA kits. Contact Ixom Watercare, Inc. Customer Service for more information.

Ixom Watercare, Inc. is committed to serving our customers. Feel free to contact a SolarBee Customer Service Representative if you experience any problems with your SolarBee. At SolarBee, we will get you technical support, parts, or a service visit to make sure that your SolarBee is back online in short time. (866) 437-8076 or customerservice@ixom.com



SolarBee Installation / Service Crew

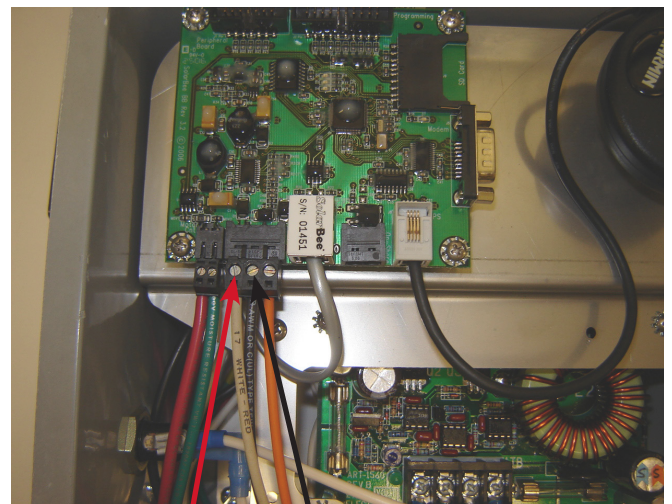

12 VDC+

12 VDC-

Troubleshooting

Troubleshooting

SB Series

Blink Indication Follow-up Procedures

Blinking Green - System healthy, machine should be operating on programmed run schedule. If not operating on programmed run schedule, contact SolarBee Customer Service.

1X Blinking Yellow - High motor current, check the machine for plugging at impeller and/or strainer-intake.

2X Blinking Yellow - Low battery voltage, machine may be operating at reduced speed or temporarily shut down due to cloudy weather period. Re-check machine after sunlight conditions improve.

5X Blinking Yellow - Check GPS connection at Brain-Board (lower right corner). If properly connected and blink code persists, contact SolarBee Customer Service.

1X Blinking Red - Anti-Jam Routine, machine is operating on a jam removal sequence triggered by high current. Check for plugging only after disconnecting power. If power is not removed first, machine may begin to operate

2X Blinking Red - 36 VDC out of range, machine may be shut down due to blown fuse (glass cylindrical) on the Zahn Board. Left side of Zahn board takes a 5 Amp Fuse, Right side of Zahn board takes a 20 Amp Fuse. Disconnect power before changing fuses. Blown fuses may be difficult to observe, so a continuity tester or new fuse should be used to confirm that the problem is not a blown fuse. If your SolarBee has a fuse switch (20 Amp), check that fuse also.

5X Blinking Red - Battery out of range, machine battery is too low. Check and record battery voltage if possible, then contact SolarBee Customer Service.

For all other blink codes, please contact SolarBee Customer Service.

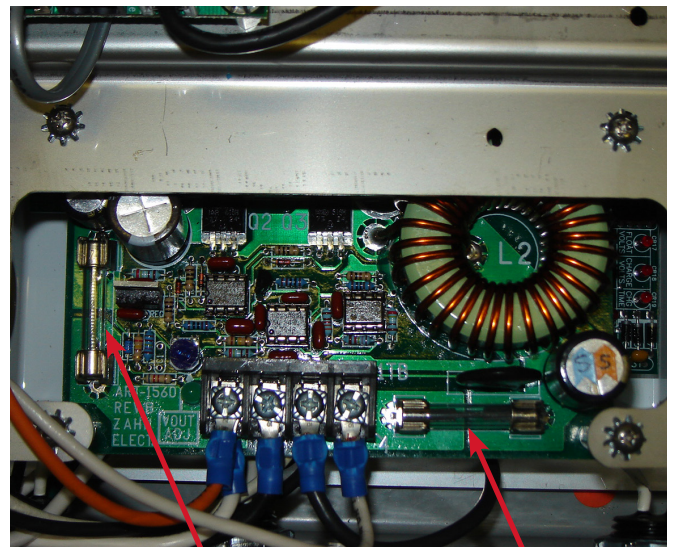
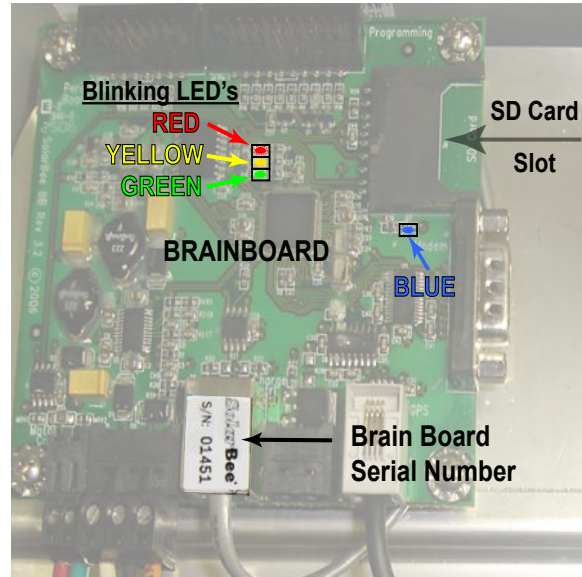

5 Amp Fuse

20 Amp Fuse

ON / OFF SWITCH

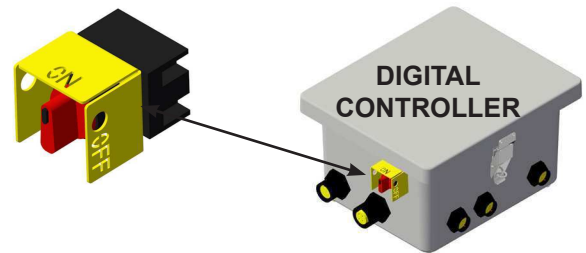

SB Series Status Codes

SB Series: Control Box Lid Label

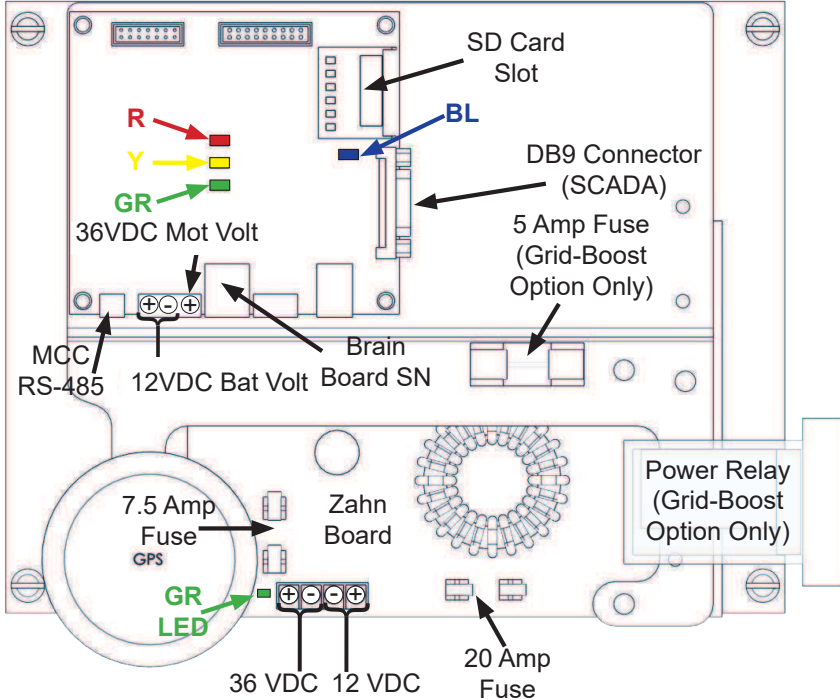

BEHAVIOR	VISUAL	INDICATION
BLINK GR		HEALTHY SYSTEM
SOLID R, Y, GR		HARDWARE ERROR
R, Y, GR OFF		HARDWARE ERROR
SOLID BL		SD CARD INSERTED
1X R, Y, GR		CUSTOM SYSTEM BOOT UP
1X R		ANTI-JAM ROUTINE
2X R		36 VDC OUT OF RANGE
3X R		MOTOR COMM ERROR
4X R		CHARGE COMM ERROR
5X R		BATT OUT OF RANGE
1X Y		HIGH MOTOR CURRENT
2X Y		LOW BATT VOLTAGE
3X Y		TEMP OUT OF RANGE
4X Y		5 VDC OUT OF RANGE
5X Y		GPS COMM ERROR
10X R, Y, GR		INCOMPLETE SD CARD UPDATE
1X Y, GR		GPS SATELLITE LOCK ERROR

Power Up and Power Down Sequence

Power Down	Component	Power Up
1	On/Off Switch	6
2	PV Panels	5
3	Grid Power (Grid-Boost)	4
4	Battery	3
5	Motor Control Cord (MCC)	2
6	Motor	1

Zahn Board Green LED	
On	12 VDC to Zahn
Off	No Power to Zahn

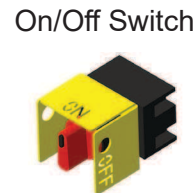
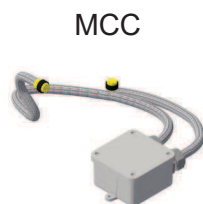
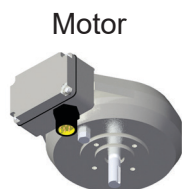

Grid-Boost Option
(36 VDC connection on right side)

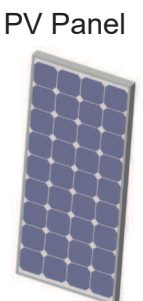
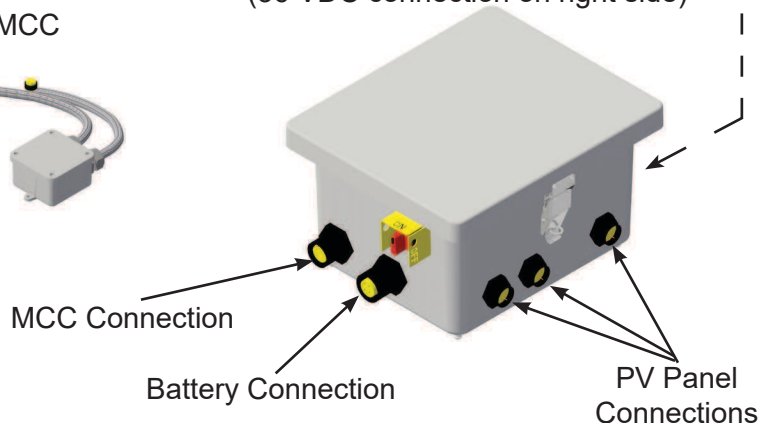

Fallback RPM Schedule

For Solar-Powered Floating Mixers

The below design calculations are in regards to the power conservation & continued operation mode of Ixom Watercare, Inc.'s solar-powered mixing control systems.

The SolarBee control system includes a brain board component with pre-programmed algorithms for reducing motor load and continuing operation by incremental speed reduction, thus incrementally reducing motor load and load being drawn from the battery. This feature is automatically enabled when extended low sunlight conditions occur or battery reserve power is reduced. This feature is commonly referred to as Fallback RPM.

Below is the detailed Fallback RPM chart, based on battery voltage and percentage of commanded or scheduled run speed, typically programmed for full speed of 80rpm.

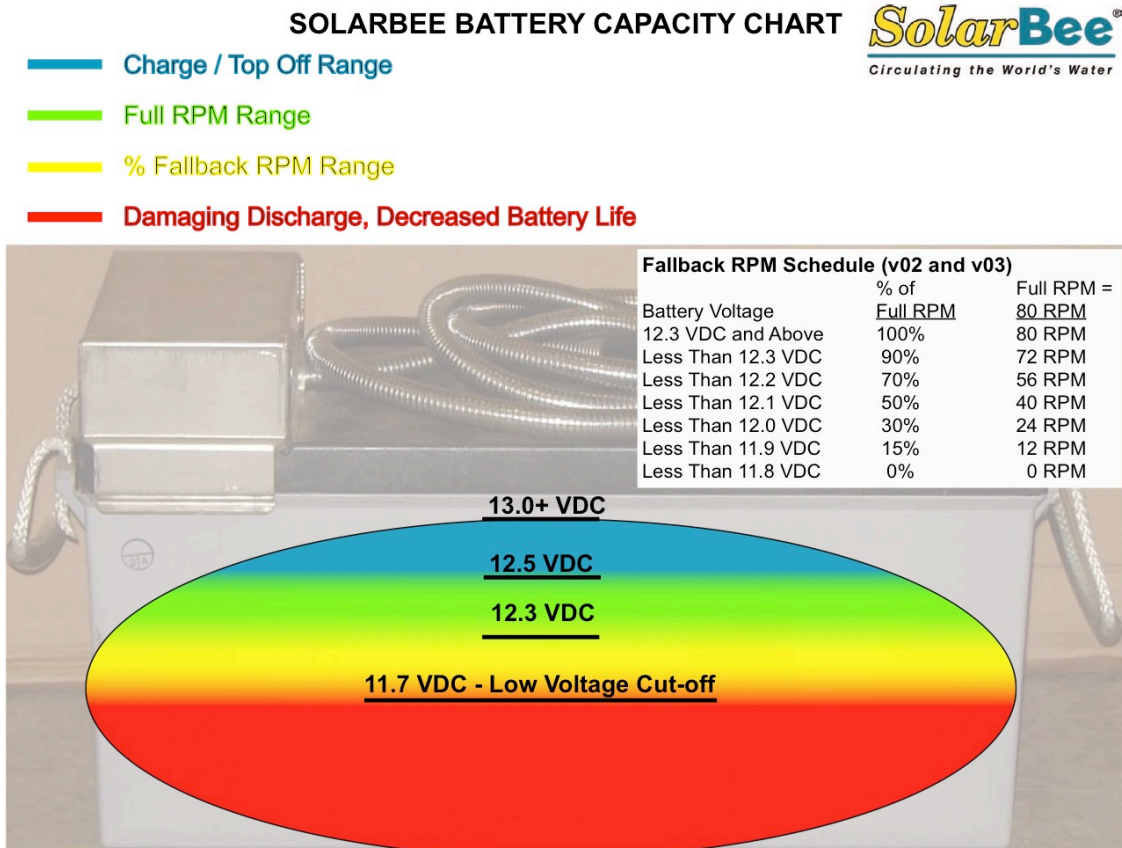

Parts Diagram

SB500PWc Parts Diagram

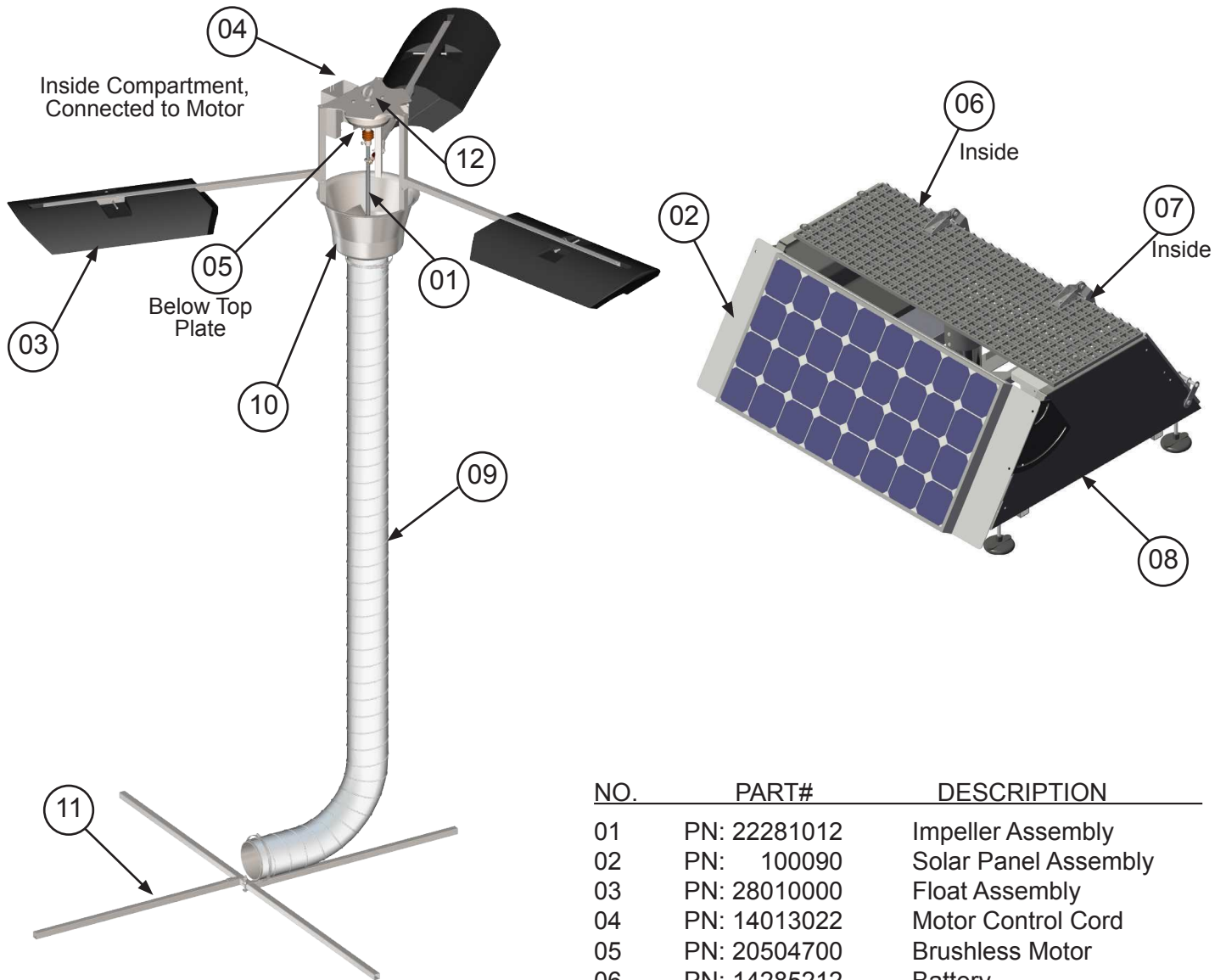

NO.	PART#	DESCRIPTION
01	PN: 22281012	Impeller Assembly
02	PN: 100090	Solar Panel Assembly
03	PN: 28010000	Float Assembly
04	PN: 14013022	Motor Control Cord
05	PN: 20504700	Brushless Motor
06	PN: 14285212	Battery
07	PN: 14300000	Control Box
08	PN: 18264150	Low Profile Stand
09	PN: 26060640	6" x 40' Hose
10	PN: 18010010	Distributor Dish
11	PN: 26260640	Torque Bar Assembly
12	PN: 12010410	Pad Eye - (For lifting)

Dimension Drawing

500PWc Dimension Drawing

SB / GF Series Small Frame Mixers

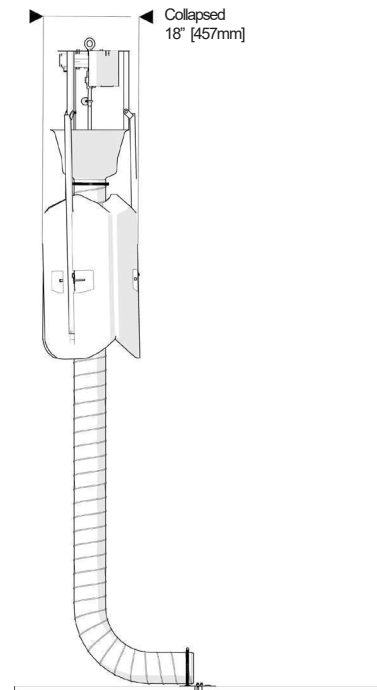
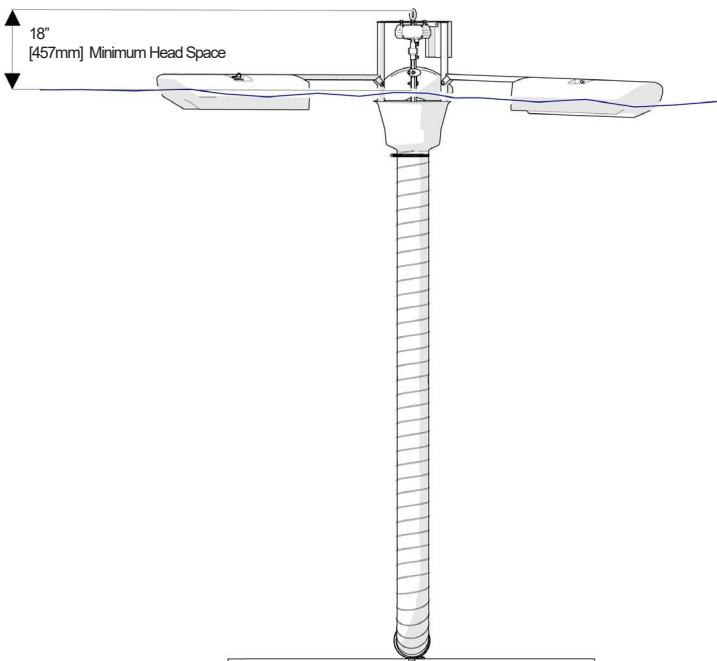
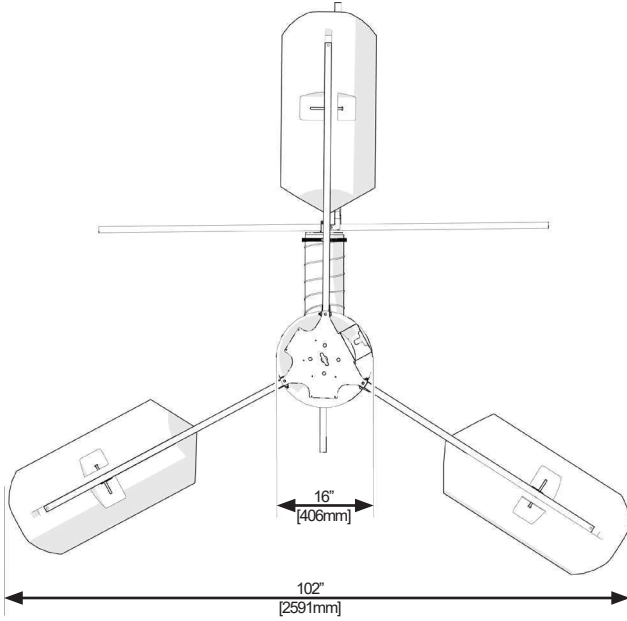

Appendices



Appendix

Additional Component Information

Technical Data Sheets

Protect Your Investment With The Ixom Service Program

Comprehensive Damage Repair

Damage which occurs to your Ixom manufactured equipment in the normal course of operation will be repaired or replaced including supply and installation of structural repairs and replacement parts in accordance with Ixom's standard terms & conditions.

Trained & Experienced Service Technicians

The Ixom Service Program allows our customers to take advantage of our highly trained service technicians. We have the equipment, experience and training to ensure the machines are well maintained while following OSHA regulations. Our dedication to safety and high level of training has earned us the prestigious SHARP recognition award time and time again. We have the means to safely service the equipment whether in municipal water tanks, lakes, reservoirs, or wastewater ponds & basins.



Guaranteed Annual Onsite Maintenance

Ixom service personnel will perform a minimum of one (1) onsite equipment inspection & maintenance per yearly term of the service contract including mechanical, structural, and electronic components of Ixom manufactured equipment.



On-Site Crew Response for Critical Application and Operational Service Issues

If service issues arise, the customer may be asked to perform a basic machine inspection and discuss results with Ixom's Customer Service Department. In some cases, the customer may be asked to perform minor tasks (i.e., cleaning, basic troubleshooting, and replacing minor parts). If replacement parts are needed, the factory will ship them out at no cost. For more serious application and service issues, Ixom will dispatch service personnel to resolve the issues onsite.

Removal, Storage, and Redeployment of Equipment

For situations when Ixom equipment needs to be removed, stored, and redeployed, services can be offered at a discounted rate.

Access to On-Staff Water Quality Experts

Ixom employs many experts in the water quality field including specialized areas such as limnology, hydrology, wastewater, biology, and engineering. Our water quality personnel are available for data analysis and troubleshooting when you need it.



Contact us for a quote!

Call +1 866-437-8076 or email us at watercare@ixom.com

Technical Data Sheet

SB500PWc

Technology Description- Floating, solar powered, circulation equipment for potable water reservoirs. Day/night operation on solar only by utilizing a battery to store excess daytime power for nighttime operation.

Materials of Construction - T316 stainless steel constructions.

Foam-filled high-density polyethylene (HDPE) floats.

Thermoplastic rubber intake hose. HDPE Strainer.

The SB500PWc is NSF/ANSI Standard 61 Listed, includes NSF/ANSI 61, Annex G.



Minimum Access Opening / Machine Size / Weight - Machine can be installed through 18 inch (457 mm) diameter opening. Assembled machine is 8 feet (2.5 meter) in diameter and weighs 85 pounds (40 kg).

Drive System - High torque, direct drive (no gearbox), low voltage brushless D.C. motor.

Minimum Operating Depth - At depths below 2 feet (0.6 meters), the impeller will be out of the water and the machine will stop circulating water. No damage to machine if ran dry in shallow water.

Minimum Head Space - 18 inch (457 millimeters) headspace is required.

Flotation System - Three floats in triangular pattern each with an adjustable float arm for proper vertical positioning, total float buoyancy of 300 pounds (140 kg).

Power Supply/Control System - *Photovoltaic (PV) Solar Panel, Battery and Electronic Controller are mounted on rack outside.*

PV Solar Panels: 80-watt photovoltaic solar panel. Battery storage for day/night operation.

Electronic Controller: Digital, solid-state controller, mounted in weather-tight (NEMA 4X) enclosure with internally fused disconnect. SCADA output through RS-232 Serial Communication (Modbus RTU), DB9 male connection point inside enclosure. Wireless options available, not included.

Wiring: Corrosion-resistant industrial cord with molded watertight connectors that are indexed to prevent improper wiring. Low voltage in reservoir, less than 36 VDC.

Rotating Assembly - Removable assembly with easy access to impeller and impeller shaft.

Fluid Intake Assembly - *Intake hose banded to bottom of structural assembly.*

Intake Hose : 20 to 100+ feet (6 to 30+ m) available in 6-inch (152 mm) diameter X 20 feet (6 m) sections.

Torque Bar, Chemical Injection: Torque bar placed at bottom end of hose, positions open end of hose at bottom floor of reservoir.

Chlorine Boosting - Chlorine boost hose, accessible at top of reservoir spans down and connects to intake for fast chlorine dispersion during in-reservoir boosting.

Accessories Available - (1) Portable Disinfectant Boost System, (2) LED RPM Indicator (3) Supplemental Power Kit, and (4) Wireless SCADA Kit.

Shipping Size / Weight

- **Crate** - 4 feet W X 6 feet L X 5 feet H (1.2 m x 1.8 m x 1.5 m) / 500 pounds (225 kg) *Exact weight and dimensions varies dependent on machine configuration.*

Maintenance / Warranty - Minimal maintenance. Limited 2-year parts and labor warranty.

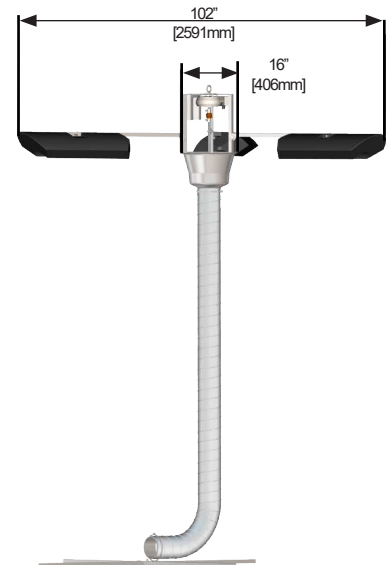

Figure 1: SB500PWc

SB A-Series Control Panel

Part Number: 14300000

Description

The SB A-Series Control Panel enables the solar powered SB units to charge a deep cycle 12VDC battery and allow continuous operation. Contains control board for autonomous control, data logging and SCADA monitoring. Also takes advantage of MPPT charging technology to ensure maximum solar power is utilized. Robust DC-DC converter to power the impeller motor.

Power Source Required

1 to 3 - 90 W, 36 Cell Monocrystalline Solar Panels
1 - 212 Ah, 12VDC Deep Cycle Battery

SCADA

A SCADA output is available as a standard in RS-232 DB9 male connection and follows Modbus RTU protocol. Accessory SCADA options for other output formats may be available upon request.

SCADA Monitoring Accessories

Additional SCADA monitoring accessories are available upon request. These include, but are not limited too, RS232-RS485 converter, wireless radios, and Modbus Master converter.

Enclosure

10 inch X 8 inch X 6 inch, NEMA 4X Fiberglass
Mounting Feet Hole Pattern: 7.01" W X 11.19" H
Back Plate Hole Pattern: 6.25 inch W X 8.25 inch H

Shipping Size/Weight

16 inch X 13 inch X 11 inch, 16 lbs

Warranty

Reference SB Limited Replacement Warranty.

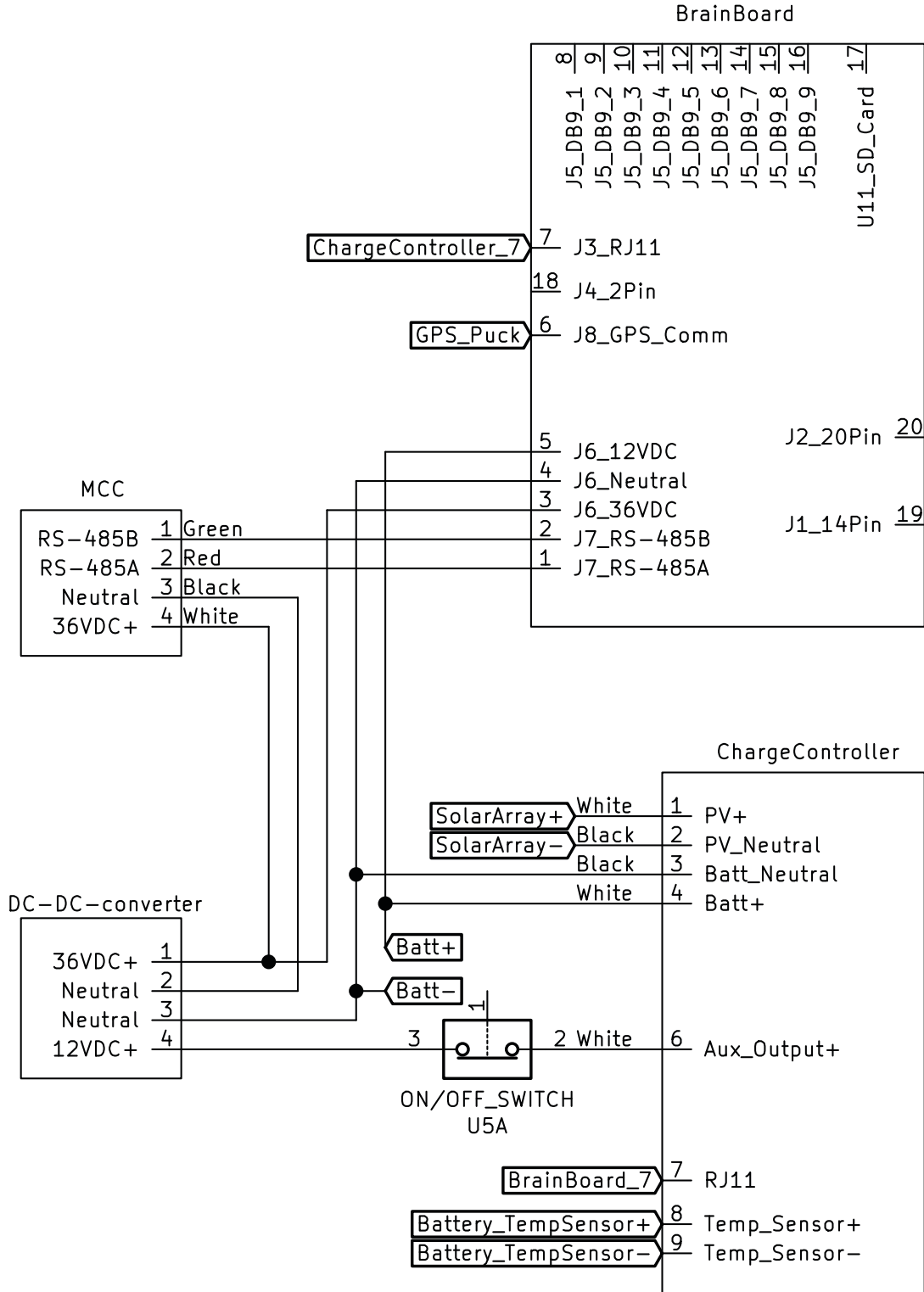

Figure 1: SB A-Series Control Panel, External



Figure 2: SB A-Series Control Panel, Internal

SB Series A-Box Wiring Schematic



Electrical

Electrical Schematic

SB Series - A Box

Key	
MC	Motor Controller
BB	Brain Board
M	Motor
PV	Photovoltaic Panel

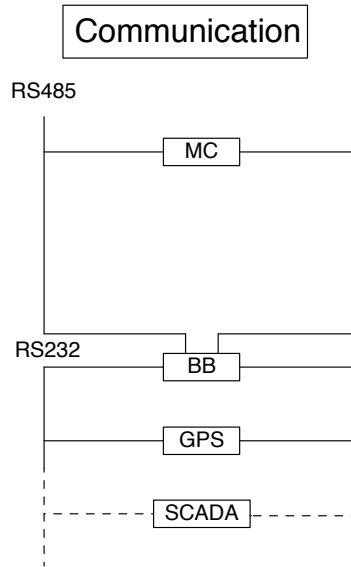
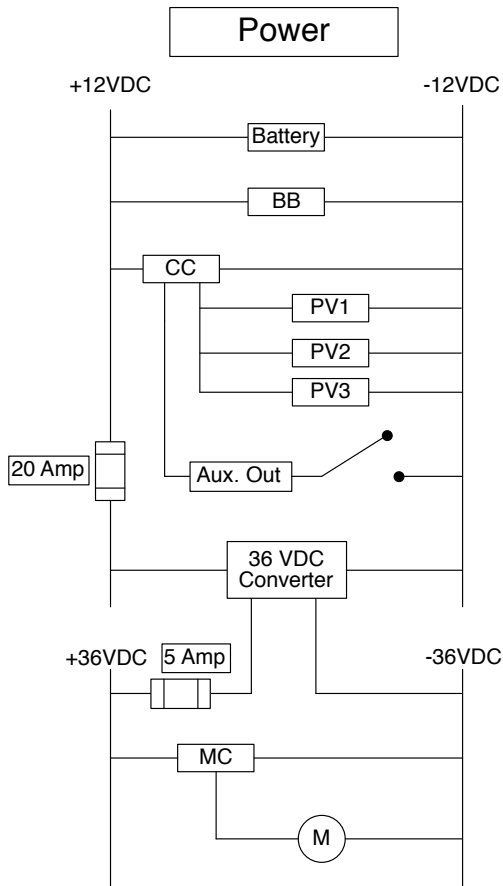

SB B-Series Control Panel

Part Number: 14300005

Description

The SB B-Series Control Panel enables the solar powered SB units to charge a deep cycle 12VDC battery and allow continuous operation. Also utilizes supplemental grid power from the shore. Contains control board for autonomous control, data logging and SCADA monitoring. Also takes advantage of MPPT charging technology to ensure maximum solar power is utilized. Robust DC-DC converter to power the impeller motor.

Power Source Required

- 1 to 3 - 90 W, 36 Cell Monocrystalline Solar Panels
- 1 - 212 Ah, 12VDC Deep Cycle Battery
- 1 - Supplemental 36VDC Shore Power (Additional Shore Power Box Needed)

SCADA

A SCADA output is available as a standard in RS-232 DB9 male connection and follows Modbus RTU protocol. Accessory SCADA options for other output formats may be available upon request.

SCADA Monitoring Accessories

Additional SCADA monitoring accessories are available upon request. These include, but are not limited too, RS232-RS485 converter, wireless radios, and Modbus Master converter.

Enclosure

10 inch X 8 inch X 6 inch, NEMA 4X Fiberglass
Mounting Feet Hole Pattern: 7.01" W X 11.19" H
Back Plate Hole Pattern: 6.25 inch W X 8.25 inch H

Shipping Size/Weight

16 inch X 13 inch X 11 inch, 16 lbs

Warranty

Reference SB Limited Replacement Warranty.

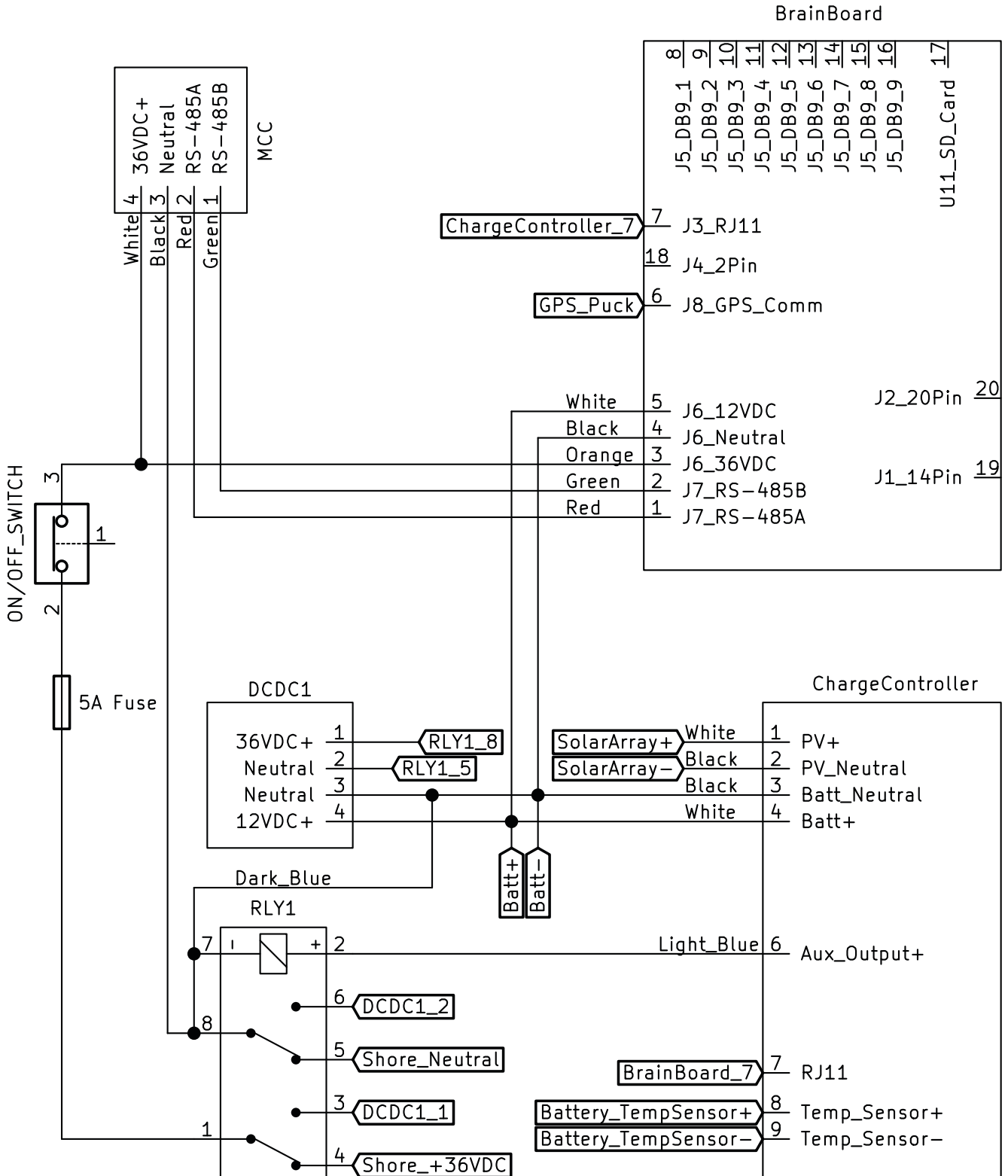

Figure 1: SB B-Series Control Panel, External



Figure 2: SB B-Series Control Panel, Internal

SB Series B-Box Wiring Schematic



Electrical Schematic

SB Series - B Box - Grid Boost

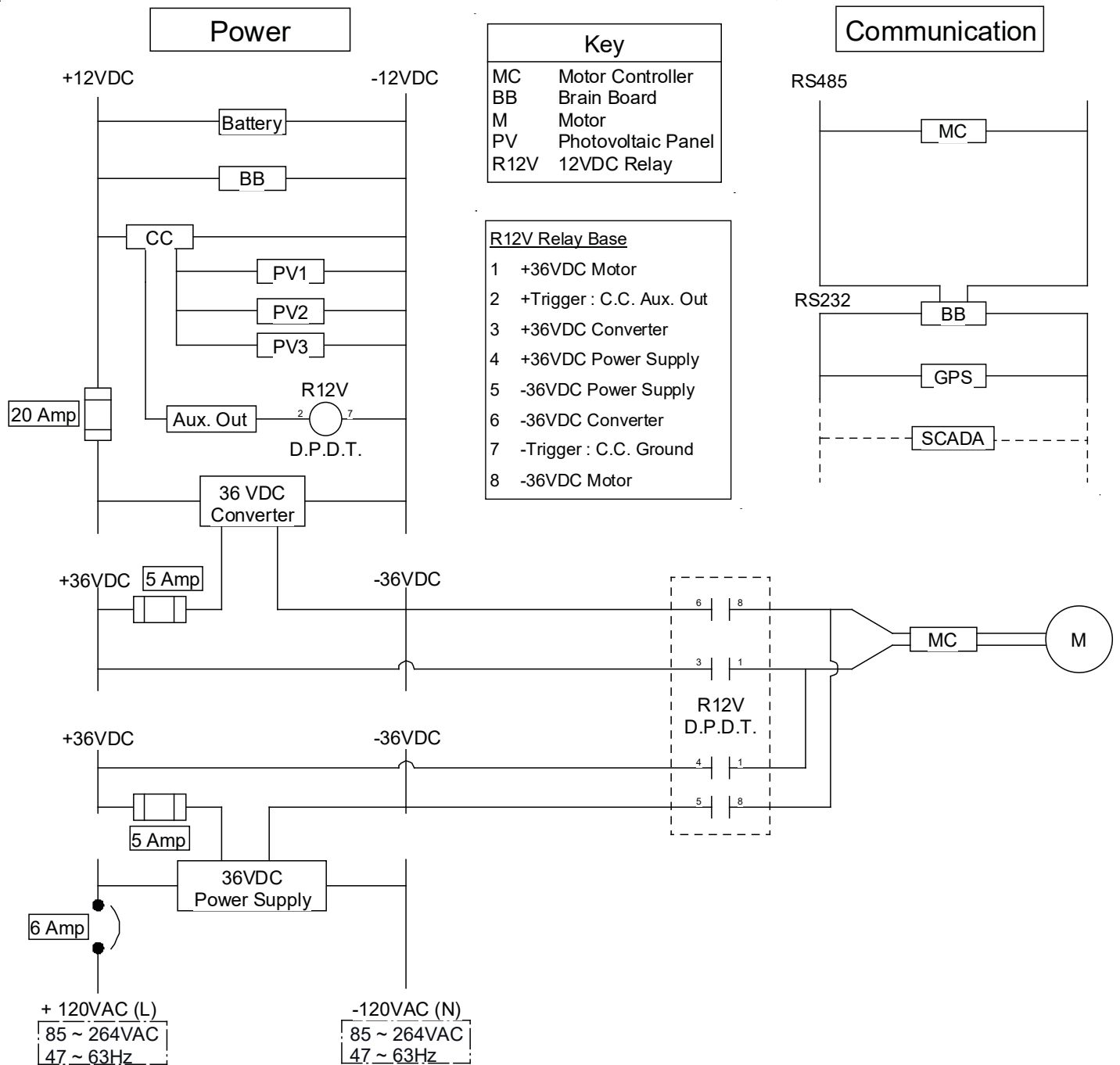

SolarBee Standard SCADA Output

The SolarBee digital controller comes standard with the following SCADA output capabilities: Controller shall have RS-232 serial communication (Modbus RTU), DB9 male connection point.

Parameters available for monitoring:

- 1) System Status (OK or Fault)
- 2) Visual Status Indicator
- 3) Motor RPM & Direction
- 4) Motor Current
- 5) Battery Voltage
- 6) Input Charge Current

SCADA Accessory Packages:

- Wireless Radio
- Analog Output
- RS-232 to RS-485 Converter
- LED RPM Indicator

SolarBee Monitoring Setup Information

The SolarBee is a modbus RTU slave device with a factory programmable slave ID. The ID can be changed in the field with a properly programmed SD card. Contact Ixom Watercare, Inc. Customer Service for assistance.

Serial Interface

Type: RS-232

Connector: 9 pin male D-Sub

Pin assignments:

- | | |
|---|---|
| 1 | n/c |
| 2 | RXD Receive Data Input |
| 3 | TXD Transmit Data Output |
| 4 | n/c |
| 5 | Signal Ground |
| 6 | n/c |
| 7 | n/c |
| 8 | n/c |
| 9 | +12VDC, 1 Amp max
(Can be used to power some serial devices) |

Serial/modbus Communication Parameters

Rate: 19200 Baud

Bits/byte: 8

Stop bits: 1

Parity: N (none)

Handshake: None

Time between bytes sent to SolarBee controller:
No greater than 20 milliseconds

Time between commands sent to SolarBee controller:
At least 50 milliseconds

Read Holding Register

The SolarBee supports modbus Function 3 - Read Holding Register.

A properly formatted "Read Holding Register" modbus message will be replied to with holding register data. The "Read Holding Register" message consists of the SolarBee slave address, the function (3), two bytes of register address, two bytes of number of points, and the CRC. The address of the holding registers can be found in the table on the next page.

The format of the reply consists of the SolarBee slave address, the function (3), a byte count (number of data bytes), two bytes of data for each of the requested points, and the CRC.

When monitoring several SolarBees on the same modbus network, query them sequentially. That is, query one SolarBee and wait for its response, query the next SolarBee and wait for its response, etc. Querying the SolarBees in a manner such that the query/response messages can overlap or collide will cause inconsistent communication.

SolarBee Standard SCADA Output

Description of Holding Registers in Order of Importance

(Memory Table starts at zero, 0)

Register Address (Base 10)	Status Item	Description
4	Current Epoch High	This is the date and time data for the SolarBee. The format is the same as that of the “Unix epoch”, (Epoch High * 65536 + Epoch Low), where the value is the number of seconds since 00:00:00 UTC on January 1, 1970. This value is set by the GPS hardware in the SolarBee controller. Querying register 5 and testing the response against the previous value is a good way to monitor the communication link between the modbus master and the slave SolarBee controller.
5	Current Epoch Low	
7	System Status	During normal operation this value is 0 (Zero). Any other number indicates an error. It is important to monitor this register since the SolarBee controller reports last known values it received from subsystem modules. For example, if the SolarBee controller loses communication with the motor control module, it will indicate this in this system status register but continue to report the last known motor RPM and current values.
9	Visual Status Indicator	This value gives an indication of the SolarBee controller health blink indicator. During normal operation the following values will appear: 0 = (1 Blink Green = Healthy System) 32 = (2 Blink Yellow = Low Battery, Healthy System) 1 = (1 Blink Red = AntiJam Sequence), high current may self correct 256 = (1 Blink Green & 1 Blink Yellow = Acquiring GPS Satellite Signal) Any other indication requires attention: 2 = (2 Blink Red = 36V Out Of Range) 3 = (3 Blink Red = Motor Controller Communication Error) 4 = (4 Blink Red = Charge Controller Communication Error) 5 = (5 Blink Red = Low Battery Limit) 16 = (1 Blink Yellow = High Motor Current) 48 = (3 Blink Yellow = Temperature Out Of Range) 64 = (4 Blink Yellow = 5V Out Of Range) 80 = (5 Blink Yellow = GPS Communication Error)
10	Motor Speed	The unit for this value is RPM in hundredths. To obtain RPM, divide the value by 100.
11	Motor Direction	The value of 0 indicates that the motor will be stopped, the value of 1 represents movement in the forward direction, whereas the value of 3 indicates reverse movement. Viewed from behind or above the motor clockwise motion is “forward”.
12	Motor Current	The unit for this value is milliamps.
13	Battery Voltage	The unit for this value is Volts. The value is scaled using this formula: value / 10.
14	Input Current	The current that is input to the controller via the solar array or shore power connections. The unit for this value is Amps. The value is scaled using this formula: value / 10.

SolarBee Standard SCADA Output

Logic Diagram

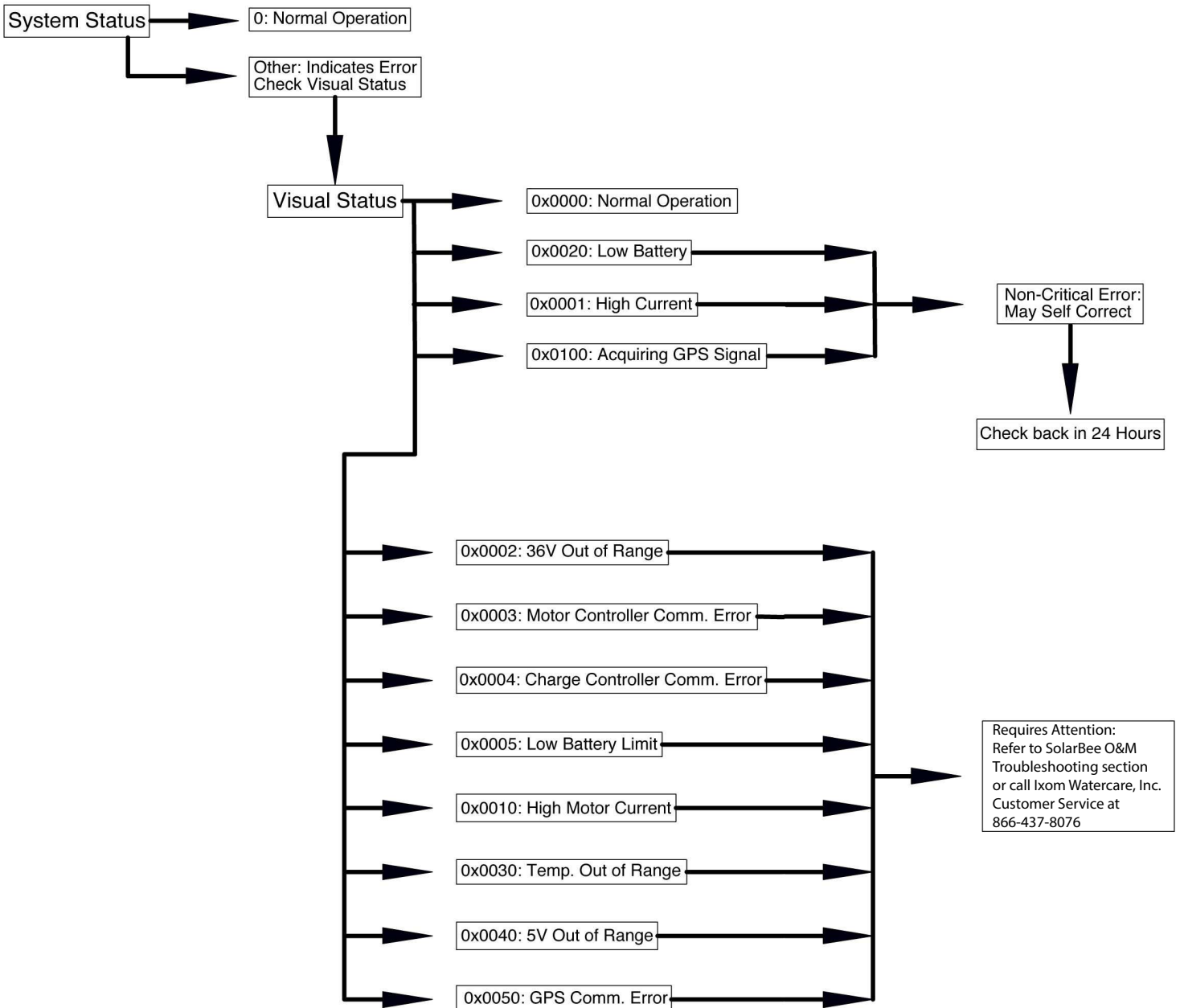

System Status for SolarBee SCADA Integration

Register Address 7 (Base 10)

Value of Zero indicates normal, healthy operation. Any other value indicates a subsystem or multiple subsystem errors. See below.

Binary Designation(s)	Decimal Value	Error Meaning
Bit 0 = 1	1	GPS Communication (Comm) Error
Bit 1 = 1	2	Charge Controller Comm Error
Bits 0 and 1 = 1	3	GPS Comm and Charge Controller Comm Error
Bit 2 = 1	4	Motor Comm Error
Bits 0 and 2 = 1	5	GPS Comm and Motor Comm Error
Bits 1 and 2 = 1	6	Charge Controller Comm and Motor Comm Error
Bits 0, 1, and 2 = 1	7	GPS Comm, Charge Controller Comm, and Motor Comm Error
Bit 3 = 1	8	Analog Out of Range (OOR) Error
Bits 0 and 3 = 1	9	GPS Comm and Analog OOR Error
Bits 1 and 3 = 1	10	Charge Controller Comm and Analog OOR Error
Bits 0, 1, and 3 = 1	11	GPS Comm, Charge Controller Comm, and Analog OOR Error
Bits 2 and 3 = 1	12	Motor Comm and Analog OOR Error
Bits 0, 2, and 3 = 1	13	GPS Comm, Motor Comm, and Analog OOR Error
Bits 1, 2, and 3 = 1	14	Charge Controller Comm, Motor Comm, and Analog OOR Error
Bits 0, 1, 2, and 3 = 1	15	GPS Comm, Charge Controller Comm, Motor Comm, and Analog OOR Error

For Customer Service, contact Ixom Watercare, Inc. Main Office and Service Center at 866-437-8076.

Visual Status Indicator Priority Levels

Register Address 9 (Base 10)

Table 4 - Status Indicator Priority Levels		
Priority Level	LED Behavior	Indication / Cause
Priority 1	5x Red	Battery Voltage is Out of Range: Vbat < Analog Battery Monitor Lower Limit (11.4V) or Vbat > Analog Battery Monitor Upper Limit (17.5V)
Priority 2	1X Red	AntiJam Mode has been activated: Motor Current > AntiJam A Trigger Current (4.5A) or Motor Controller Error has been received.
Priority 3	2X Red	36V Supply is Out of Range: 36V supply < Analog 36V Monitor Lower Limit (33.0V) or 36V supply > Analog 36V Monitor Upper Limit (39.0V). If the Charge Controller has the Auxiliary Output turned off, this error is not displayed. * Improper power down and power up sequence. Charge controller locked out. (e.g. battery replacement).
Priority 4	3X Red	Motor Controller not communicating properly. If the Charge Controller has the Auxiliary Output turned off, this error is not displayed.
Priority 5	4X Red	Charge Controller not communication properly.
Priority 6	1X Yellow	Motor Current > Visual Motor Current Threshold (3.5A)
Priority 7	2X Yellow	Vbat < Visual Low Battery Threshold (12.1V)
Priority 8	3X Yellow	Temperature Reading is Out of Range: Temp < Analog Temperature Monitor Lower Limit (0°F) or Temp > Analog Temperature Monitor Upper Limit (176°F)
Priority 9	4X Yellow	5V Supply is Out of Range: 5V supply < Analog 5V Monitor Lower Limit (4.5V) or 5V supply < Analog 5V Monitor Upper Limit (5.5V)
Priority 10	5X Yellow	GPS Unit not communicating properly

Small 7" Brushless Motor

Motor Features

Technology Description- Designed for Solarbee and Gridbee circulation equipment. The brushless direct drive motor provides high torque, eliminates costly gearboxes, and provides high reliability. The motor requires no brush replacement, no lubrication, and no routine maintenance. An iron free stator eliminates iron saturation to provide long life. It also provides a smooth, vibration free operation. Quite operation at low speeds. Operational power requirements utilize low voltage DC power. Using hall effects for electronic communication. Provides effective use of solar and DC energy.

7" Motor Specifications		
Size	7-inch (18cm) diameter X 4-inch (10cm) height	
Weight	25 lb (12 kg)	
Housing	Sealed 356-T6 Cast Aluminum	
Shaft	Stainless Steel: V-ring seal	
Thrust Bearing	L10: 100,000 hrs. Stainless Steel	
Motor Control	Anti-Corrosive coating on flux returns and magnets Encapsulated stator Conformal coating on commutation circuit board Hall Effect Commutation	
Receptacle	#16-9, 7A, 600V AC/DC, IP68, NEMA 6P, UL/CSA	
	Normal Operation	Maximum Motor Ratings
Current	Less Than 0.5 Amp	2.4 Amps
Voltage	36 VDC	36 VDC
Torque	1ft-lb (1.4 N-m)	10 ft-lb (14 N-m)
Power	1/50 HP (15 W)	1/8 HP (86 W)
Environment	-40 to 140°F, freeze resistant, 100% humidity, splash and condensation resistant	

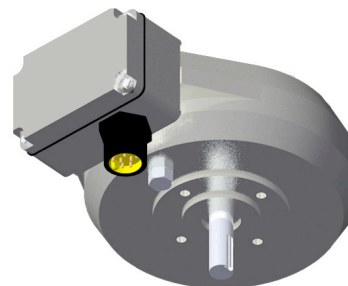
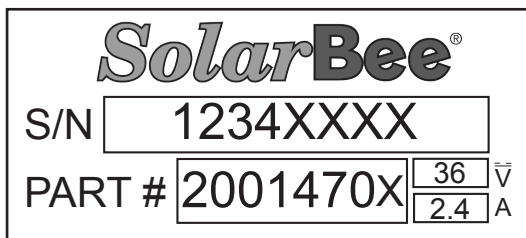

Shipping Size/Weight

- 14" x 10" x 9", 30lbs.

Maintenance / Warranty - No routine maintenance. Limited 2- year parts and labor warranty.

Technical Data Sheet

Sun Xtender Submersible Solar Battery

PART NUMBER: 14285212

DESCRIPTION:

Core Manufacturer: Concord Corp.
Sun Xtender Solar Battery, VRLA-AGM Deep Cycle Battery for Off Grid and Grid Tied Systems

CONSTRUCTION:

Thick walled polypropylene copolymer container and sealed cover. PolyGuard protection used around the positive plate and AGM prevents shorting from shock and vibration. Sun Xtender is the only battery offering this added layer of protection. Recombinant gas Sun Xtender® Series solar batteries are valve regulated lead acid (VRLA) batteries, providing explosion resistance.

APPROVALS:

UL 1989 (Standby Battery), File Number MH-17983. Sun Xtender® Series batteries ship Hazmat EXEMPT. Complies with 49 CFR 173.159a, DOT HMR49, ICAO and IATA, Special Provisions S.P.A67 & A48.

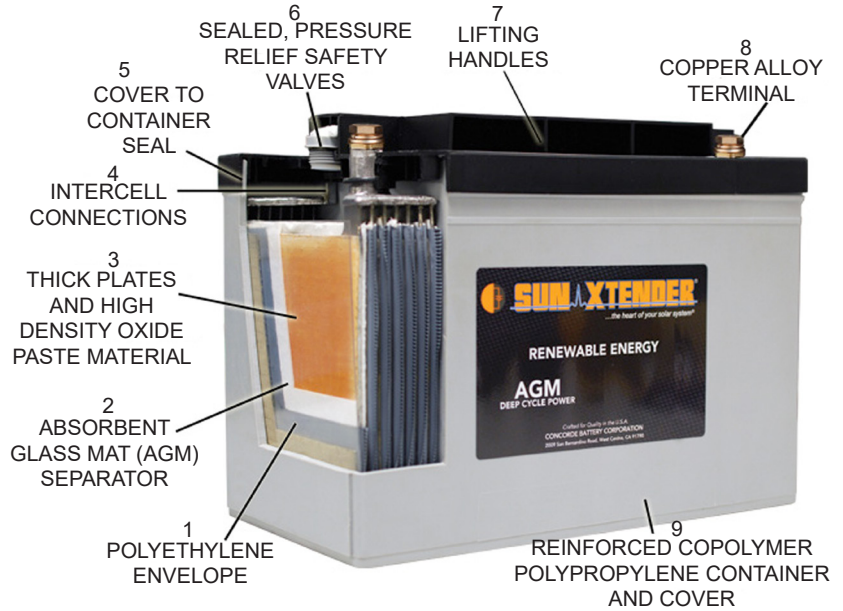

1. Eliminates internal shorts caused by shock, vibration & dendrite growth.
2. Custom designed and manufactured to provide superior wicking characteristics for electrolyte retention.
3. Insures long life, excellent cycling capability.
4. Massive "over-the-partition" weld increases the weld strength & provides low resistance connection path.
5. Strong, epoxied tongue & groove cover/container seal will not separate even under extreme temperature & pressure changes or vibration.
6. Operates in any orientation without leaking. Maintenance-free: never requires water additions.
7. Easier handling, carrying & installation.
8. Provides low resistance electrical connection (copper-to-copper), non-corrosive, increased environmental protection & personal safety- no exposed lead.
9. High impact resistance and resists bulging even under severe overcharge and temperature. Shock proof and freeze tolerant.

4 PIN MALE FACE VIEW

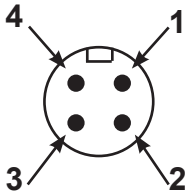

- | | | |
|------------|-------|--------------------|
| 1 - 12 AWG | Black | -12VDC Power |
| 2 - 12 AWG | Green | Temperature Sensor |
| 3 - 12 AWG | Red | Temperature Sensor |
| 4 - 12 AWG | White | +12VDC Power |

Electrical and Physical Properties:

Voltage: 12V
Weight: 145 lb (65.77 kg)
Battery Series: 12 Volt Sun Xtender Series
Cord Length: 7 ft T316 SS Sheathed
Self Discharge Rate: 1-3%/month - remains stable over life.
IP Rating: IP68
Nominal Capacity Ampere Hours:
 @ 25° C (77° F) to 1.75 Volts per cell

24 Hr Rate: 212Ah
 48 Hr Rate: 235Ah
 72 Hr Rate: 244Ah

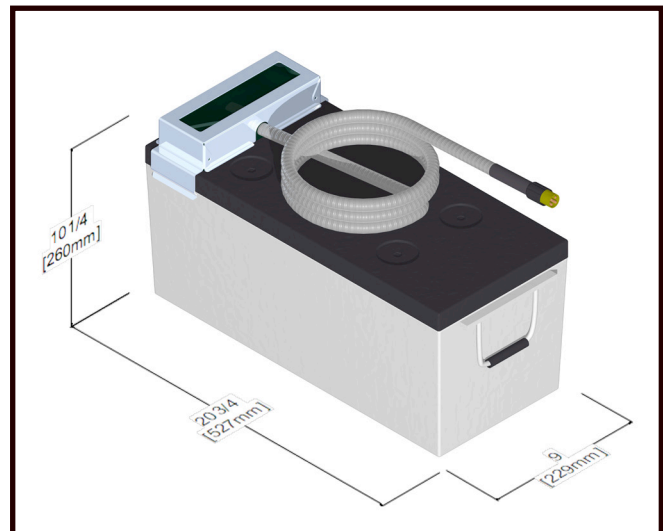

Warranty



Solar SB Mixers

Limited Replacement Warranty

SolarBee SB Mixers. All new and factory-refurbished SolarBee SB mixers and circulators are warranted to be free of defective parts, materials, and workmanship for a period of two years from the date of installation. SolarBee SCADA and any optional accessories are considered “buyout” items for Ixom, and as such include a warranty against defects in material and workmanship for two years from the date of purchase. Parts that are determined by Ixom to be defective in material or workmanship under normal use during the two year warranty period will be repaired or replaced. Any shipping charges that may apply are the responsibility of the customer. This warranty is valid only for SolarBee equipment used in accordance with the owner’s manual, and consistent with any initial and ongoing factory recommendations. This warranty is limited to the repair or replacement of defective components only and does not apply to normal wear and tear. If the factory’s service crews performed the original on-site placement and startup, then this warranty also includes labor. Where labor is included, in lieu of sending a factory service crew to the site for minor repairs, Ixom may choose to send the replacement parts to the owner postage-paid and may pay the owner a reasonable labor allowance, as determined solely by Ixom, to install the parts. There is no liability for consequential damages of any type. The warranty that is submitted and provided with the purchased equipment is the valid warranty.

Terms applicable to all equipment. This Limited Replacement Warranty is subject to the terms of Ixom’s General Terms and Conditions of Sale. In the event of any inconsistency between the terms of this Limited Replacement Warranty and Ixom’s General Terms and Conditions of Sale, the terms of this Limited Replacement Warranty shall prevail to the extent of that inconsistency.

Protect Your Investment With The Ixom Service Program

Comprehensive Damage Repair

Damage which occurs to your Ixom manufactured equipment in the normal course of operation will be repaired or replaced including supply and installation of structural repairs and replacement parts in accordance with Ixom's standard terms & conditions.

Trained & Experienced Service Technicians

The Ixom Service Program allows our customers to take advantage of our highly trained service technicians. We have the equipment, experience and training to ensure the machines are well maintained while following OSHA regulations. Our dedication to safety and high level of training has earned us the prestigious SHARP recognition award time and time again. We have the means to safely service the equipment whether in municipal water tanks, lakes, reservoirs, or wastewater ponds & basins.



Guaranteed Annual Onsite Maintenance

Ixom service personnel will perform a minimum of one (1) onsite equipment inspection & maintenance per yearly term of the service contract including mechanical, structural, and electronic components of Ixom manufactured equipment.

On-Site Crew Response for Critical Application and Operational Service Issues

If service issues arise, the customer may be asked to perform a basic machine inspection and discuss results with Ixom's Customer Service Department. In some cases, the customer may be asked to perform minor tasks (i.e., cleaning, basic troubleshooting, and replacing minor parts). If replacement parts are needed, the factory will ship them out at no cost. For more serious application and service issues, Ixom will dispatch service personnel to resolve the issues onsite.



Removal, Storage, and Redeployment of Equipment

For situations when Ixom equipment needs to be removed, stored, and redeployed, services can be offered at a discounted rate.

Access to On-Staff Water Quality Experts

Ixom employs many experts in the water quality field including specialized areas such as limnology, hydrology, wastewater, biology, and engineering. Our water quality personnel are available for data analysis and troubleshooting when you need it.



Contact us for a quote!

Call +1 866-437-8076 or email us at watercare@ixom.com

IXOM

WATERCARE

Nationwide Installation & Service

EVERYONE DESERVES GREAT CUSTOMER SUPPORT

Ixom Watercare earns customer trust with unparalleled service start to finish. Every department in Ixom is dedicated to the support of our Customers and the improvement of water quality. Complete life cycle support is much, much more than a returned phone call or an email. It centers around direct access and communication to those who can help when help is needed from the beginning of a project throughout the life of the equipment.

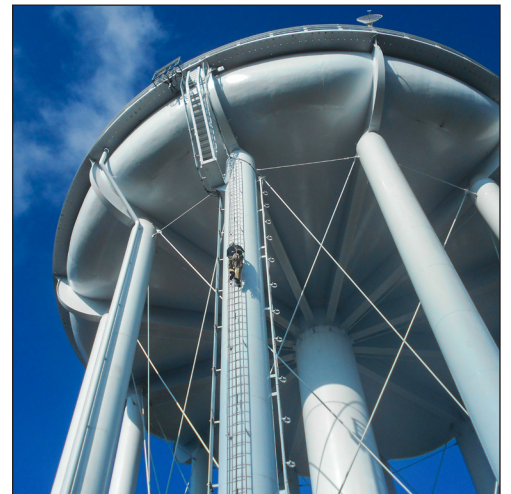

ABOUT IXOM

Ixom combines innovative water quality solutions with top notch manufacturing and nationwide in-field service capabilities to create trusted, full circle support our Customers depend on.

We design and manufacture many trusted brands including GridBee®, SolarBee®, MIEX®, and ResidualHQ® for use across the water quality spectrum. This includes solutions for Water Treatment, Distribution Treatment, Wastewater Treatment and Lakes & Source Water Reservoirs.

Ixom has thousands of installations and is an industry-leader solving water quality problems across the United States, Canada and the world.

Contact us today to discuss your water quality and service needs.

ixomwatercare.com
866-437-8076 • watercare@ixom.com