

GridBee SN10

Owner's Manual

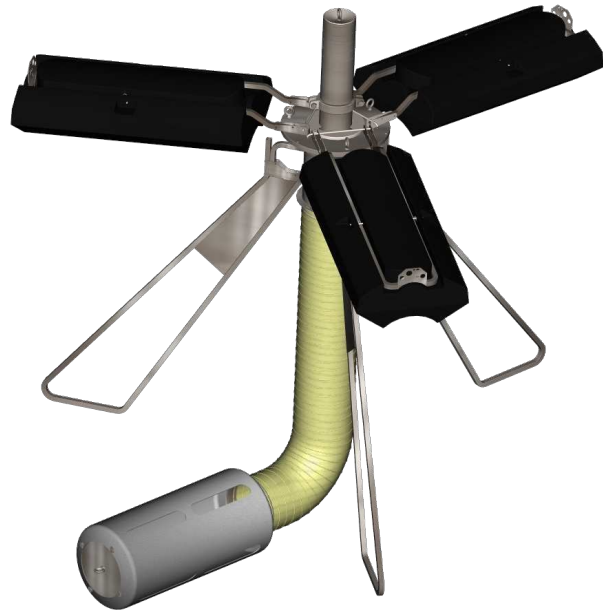

Table of Contents



GridBee SN10

Owner's Manual

Safety	1
Package Contents	4
Tools Required	6
Placement	7
Assembly	10
Electrical	17
Startup and Operation	21
Troubleshooting	22
Technical Specifications	23
Exploded Parts Diagram	24
Dimension Drawing	25
Placement Record	26
Warranty	27
Service Program	28
Customer Service	29

Safety

IMPORTANT

**YOU MUST COMPLETELY
READ AND FULLY
UNDERSTAND THESE
INSTRUCTIONS BEFORE
INSTALLING, OPERATING,
OR SERVICING THIS UNIT.**

Be sure you have read all installation, operation, maintenance and safety instructions before you install, service or begin to operate this unit.

Accidents occur every year because of careless use of industrial equipment. You can avoid hazards by following these safety instructions, and applying some ordinary common sense when operating or servicing this unit.

Keep in mind that **full operator attention and alertness** are required when operating or servicing this unit.

USE COMMON SENSE!! Most accidents can be avoided by using **common sense and concentration** on the job being done.



Carefully read safety information when you see any safety symbols.

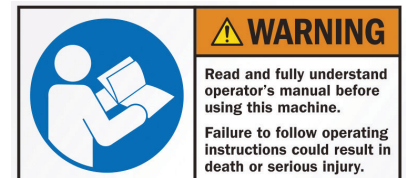

Safety

IMPORTANT

YOU MUST COMPLETELY READ AND FULLY UNDERSTAND THESE INSTRUCTIONS BEFORE INSTALLING, OPERATING, OR SERVICING THIS UNIT.

Identify all possible hazards. Determine what safeguards are needed and implement them. **Only you, the user,** understand your product and system characteristics fully. *The ultimate responsibility for safety is with you. Your safety ultimately rests in your hands.* Do your part and you will enjoy safe, trouble free operation for years to come. This instruction manual is not intended to include a comprehensive listing of all details for all procedures required for placement, operation and maintenance. If you have a question about a procedure or are uncertain about any detail, **Do Not Proceed.** Please contact Ixom Watercare Customer Service at **866-437-8076** to speak to a representative.



IMPORTANT!!!

Follow all federal and state laws in regards to safety regulations of working at heights, confined spaces, rescue, etc. as required by the U.S. Department of Labor, Occupational Safety and Health Administration. Use necessary PPE when placing and servicing this unit.



Thin Ice Hazard

WARNING: ICE SURROUNDING MACHINE MAY NOT SUPPORT WEIGHT, KEEP CLEAR OF THIN ICE.



ELECTRICAL HAZARD

WARNING: THIS EQUIPMENT CONTAINS HIGH VOLTAGE! ELECTRICAL SHOCK CAN CAUSE SERIOUS OR FATAL INJURY. ONLY QUALIFIED PERSONNEL SHOULD ATTEMPT PLACEMENT, OPERATION AND MAINTENANCE OF ELECTRICAL EQUIPMENT. REMOVE ALL SOURCES OF ELECTRICAL POWER BEFORE PERFORMING ANY SERVICE WORK TO THE MACHINE. USE PROPER LOCKOUT TAGOUT (LOTO) PROCEDURES TO ENSURE A SAFE WORK ENVIRONMENT.



Crush Hazard

WARNING: DO NOT REMOVE ANY FLOAT ASSEMBLY BOLTS OR PINS WHILE EQUIPMENT IS FLOATING IN WATER. EQUIPMENT MUST BE SECURELY SUPPORTED BEFORE PERFORMING SERVICE.



Rotating Hazard

CAUTION: KEEP BODY APPENANDAGES OR LOOSE CLOTHING AWAY FROM EQUIPMENT WHILE OPERATING. ENSURE EQUIPMENT IS OFF BEFORE ATTEMPTING SERVICE.



Entanglement Hazard

WARNING: ENSURE THAT PERSONNEL ARE CLEAR OF THE ELECTRIC CORD AND CHAIN TO AVOID ENTANGLEMENT.



Laceration Hazard

CAUTION: EDGES MAY BE SHARP AND CAUSE LACERATION IF PROPER CARE IS NOT USED.

Safety

Protect Yourself

It is important that you comply with all relative OSHA and local regulations while installing and performing any maintenance to the mixer circulation equipment.

Key OSHA Compliance Standards that must be followed (and not limited to) are:

- **1910.146 Permit-required confined spaces**
- **1910.147 Lockout/Tagout**
- **1926.500 Fall Protection**

Fall Protection Tips

- Identify all potential tripping and fall hazards before work starts.
- Look for fall hazards such as unprotected floor openings/edges, shafts, open hatches, stairwells, and roof openings/edges.
- Inspect fall protection and rescue equipment for defects before use.
- Select, wear, and use fall protection and rescue equipment appropriate for the task.
- Secure and stabilize all ladders before climbing.
- Never stand on the top rung/step of a ladder.
- Use handrails when you go up or down stairs.
- Practice good housekeeping. Keep cords, welding leads and air hoses out of walkways or adjacent work areas.

Refer to 29 CFR 1926.500 for complete regulations set by OSHA. Refer to your state's regulations if your state established and operates their own safety and health programs approved by OSHA.

Lockout Tagout

When the On/Off switch is in the "ON" position, the mixer may start up at any time if not already operating. The mixer's On/Off switch can be locked out by placing a pad lock thru the door latch of the controller after the switch has been turned to the "OFF" position. The On/Off switch is to be used as the emergency stop.



Permit-Required Confined Spaces

A confined space has limited openings for entry or exit, is large enough for entering and working, and is not designed for continuous worker occupancy. Confined spaces include underground reservoirs, ground storage tanks, elevated tanks, silos, manholes, and pipelines.

Confined Space Tips

- Do not enter permit-required confined spaces without being trained and without having a permit to enter.
- Review, understand and follow employer's procedures before entering permit-required confined spaces and know how and when to exit.
- Before entry, identify any physical hazards.
- Before and during entry, test and monitor for oxygen content, flammability, toxicity or explosive hazards as necessary.
- Use fall protection, rescue, air monitoring, ventilation, lighting and communication equipment according to entry procedures.
- Maintain contact at all times with a trained attendant either visually, via phone, or by two-way radio. This monitoring system enables the attendant and entry supervisor to order you to evacuate and to alert appropriately trained rescue personnel to rescue entrants when needed.

Refer to 29 CFR 1910.146 for complete regulations set by OSHA. Refer to your state's regulations if your state established and operates their own safety and health programs approved by OSHA.

Package Contents



SN Series Contents - Large Frame

SN10 / SN15

† Amount varies on specific tank requirements.















Qty	Unit	Part Number	Callout Number	Description	Photo
1	Each	100688	1	3DX Spray Nozzle, Fits SN10 SN15	
1	Each	101301 100354	9 11 12	Pump, Motor & Discharge Assembly, 10HP Pump, Motor & Discharge Assembly, 15HP	
3	Each	100395/100284	7 8	SN Large Float Arm Assembly	
1	Each	100541	4 5	Platform Assembly, 3 Float x 12" Flange, Large Frame SN, Finished	
† 1	Each	102611	2	Hose, 12" x 40', 316SS Wire, NSF Clear PVC	
† 2	Each	26015012	5	Hose Flange, 12" x 14ga, T316SS	
1	Each	101464	6	Intake Assembly, Round, 12" Flange, Finished Assembly, LG Frame SN	
2	Each	12558050	19	Mooring Block Anchor, 70 lb, Assembled with Concrete, Chain and Shell	
8	Each	16013107	3	Hose Clamp, 5.75" to 6.625", T316SS, High Torque	
45	Ft.	10014505		Chain 5/32", T316SS, Retrieval	
† 100	Ft.	10014018		Wire Rope, 3/16" x 7x19 Strand, T316SS	
† 100	Ft.	10503045		Electric Cord, 10Ga-4 x 600V, NSF	
1	Each	101967		SN Leg Extension Barrel Assembly, with legs	
1	Each	101284		Leg Extension Kit, 60", SN, Set of 3	
1	Each	102019		Hardware Kit: SN Leg Extension Barrel	Listed Below
1	Each	100119		Hardware Kit, SN, Large Frame, Packaged & Ready for Install, White Tote Kit	
Hardware Kit: SN Leg Extension Barrel Listed Below					
6	Each	12010305		Hairpin, 3/8"-7/16", 22-05 SS, 1-7/8" Hitch pin	
6	Each	12010312		Clevis Pin, 5/16" x 2", T316SS, Gate and Leg Ext.	
4	Each	12010102		Bolt, M8 x 20mm, T316SS	
4	Each	12010023		Nut, M8, T316SS, Nylock	
4	Each	12010213		Washer, M8, T316SS, Fender	
4	Each	100270		Hose Flange Washer, 1.25" x 2", 12Ga., T316SS	

Package Contents

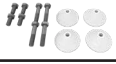

SN Series Contents - Large Frame

SN10 / SN15

Qty	Unit	Part Number	Callout Number	Description	Photo
Contents listed below and on next page are in the Hardware Kit in the White Tote.					
1	Each	34011005		*Lexel, 5.5oz, clear squeeze tube*	
1	Each	34010106		* 1-5/16" Hole Saw *	
1	Each	16013206	10	Groove Coupling, 6", T316SS NSF Gasket, SN10 and SN15	
3	Each	100445	18	Pin, 3/8" x 13.5", T316SS, Large Frame SN Float Arm Lock	
9	Each	12010305	16	Hairpin, 3/8"-7/16", 22-05 SS, 1-7/8" Hitch Pin	
6	Each	12160325	17	Float Pin, 5/16" Round Solid, 28 Parts/12' Stick	
3	Each	100446	13	Universal Float Plate, 12Ga. T316SS	
1	Each	14011116		Cord Grip, .625-.750, 3/4" NPT male thread, Nylon, For 4-Cond. 600V NSF cord	
2	Each	101312		Bus Drop Cable, .70"-.85", SS	
1	Each	14281150		Splice Kit, Large Epoxy, 4 Connectors	
1	Each	100026		Universal Penetration Kit, 1" x 6.5", T316SS Brass HDPE	
1	Each	12285160		PW Intake Pad Hardware Kit, Bagged with M8 Bolts and White Feet	
8	Each	12010412		Cable Clamp, 3/16" T316SS	
10	Each	12010104	14	Bolt, M8 x 45mm, T316SS	
16	Each	12010100		Bolt, M8 x 16mm, T316SS	
26	Each	12010023	15	Nut, M8, T316SS, Nylock	
2	Each	12010409		Eye Bolt, M8 x 1.25 x 3.25", T316SS	
6	Each	12010024		Nut, M8 x 1.25, T316SS, Standard	
4	Each	12010213		Washer, M8, T316SS, Fender	
2	Each	101107		Chain 5/32"x120", Dual Tether Chain	
12	Each	12010710		Quick Link, 3/16", T316SS	

† Amount varies on specific tank requirements.

* May or may not be in hardware kit depending on installation.

Tools Required

SN Series - Large Frame

Tools Required



1 -1/4 Wrench

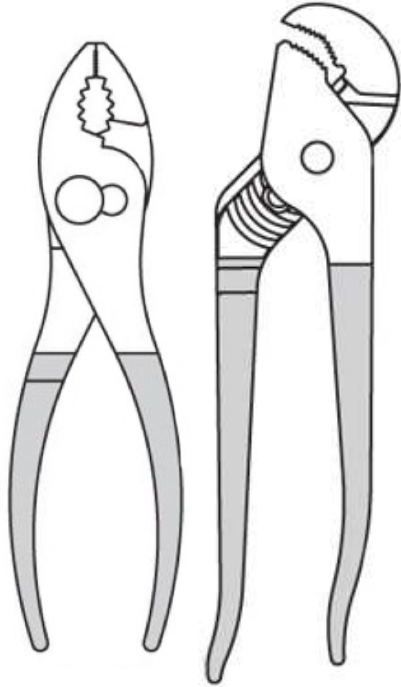

Pliers

Channel
Lock Pliers

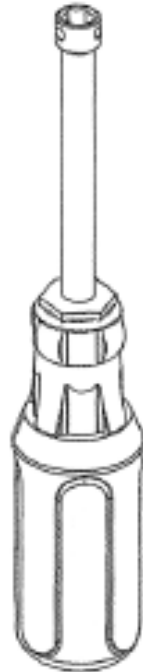

5/16" Nut
Driver

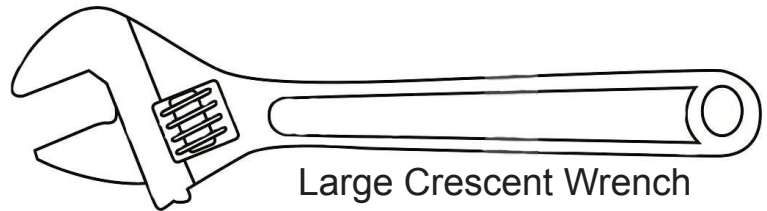

Large Crescent Wrench



13 mm Wrench



Ratchet



13mm Socket



1-1/4" Socket

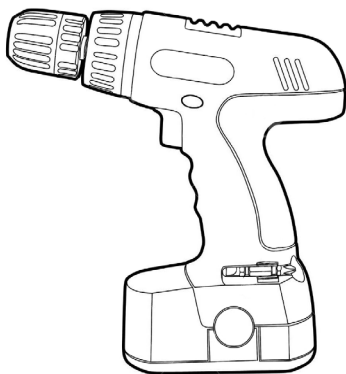

Cordless Drill With #2 Square Head
Bit and 5/16" Nut Driver Bit
for Hose Clamps

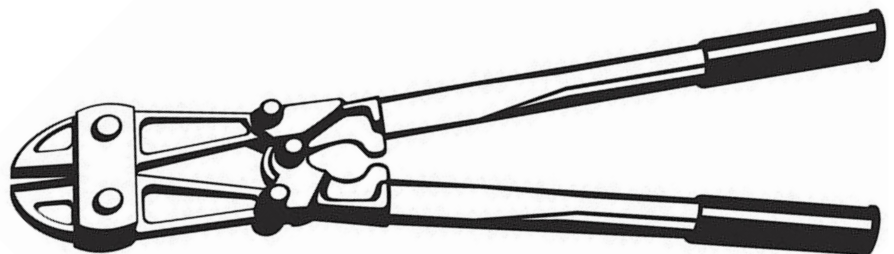

Steel Banding/Chain cutter

Placement Site Preparation

Placement Site Preparation

Large Frame SN Placement

Properly planning out the job site before proceeding is very important to performing an efficient and successful potable water equipment placement. Every potable water tank and reservoir is unique; therefore, the following are general guidelines and considerations that will need to be evaluated for each specific site.

Hatch Requirements

Hatch size must require a minimum clear opening of at least 24 inch x 24 inch square (60cm x 60cm) to allow the SN10/SN15 collapsible unit assembly to be placed. Many components can be disassembled to fit through smaller openings, however the intake box requires a minimum 24" square clearance.

Wet Or Dry Placement

A decision will be required to either place the machine while the reservoir is empty or filled with water.

Wet placements are generally preferred when the units are placed by our factory placers to allow for proper final adjustments and settings during startup which directly follows placement. Our factory placement teams have extensive training and many placement tools to assist in a wet placement.

If proper equipment and safety training are not available, a wet placement should not be attempted, and therefore a dry placement will be required and startup will have to follow at a later time once the reservoir is filled with water.

Sanitary Requirements

For potable water equipment placements, it is very important to maintain sanitary conditions by properly disinfecting all equipment and personnel that come into contact with the reservoir interior and potable water. It is recommended that once the hatch is chosen for equipment and personnel entry, a clean zone be designated around the hatch. The clean zone establishes a boundary where anything that comes in contact with that zone shall be sanitary and adequately disinfected, allowing it to pass through the clean zone and into the reservoir. Standard practice in the United States is to use a 200 part per million sodium hypochlorite in water solution as a disinfectant to all equipment and personnel clothing/footwear coming into contact with the reservoir interior and potable water.

Safety

Prior to commencing placement and finalizing the placement work areas, the jobsite should be evaluated for all safety hazards including, but not limited to: Confined Space Entry, Fall Protection, Working Over Water, Overhead Equipment, Communication Barriers, Equipment Handling, etc.

Once safety hazards are identified, hazard mitigation measures should be taken and safety training procedures must be practiced to accomplish the placement without incident.

Placement

Placement Overview

SN Large Frame Series

Details listed on this page include items provided by Others, not Ixom. Please refer to your projects Scope of Work for more details. Ixom does not provide any electric work.

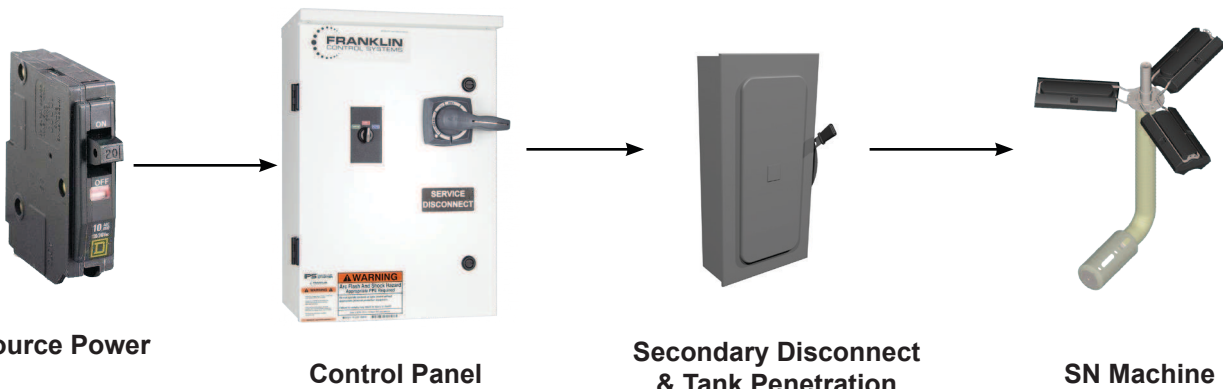
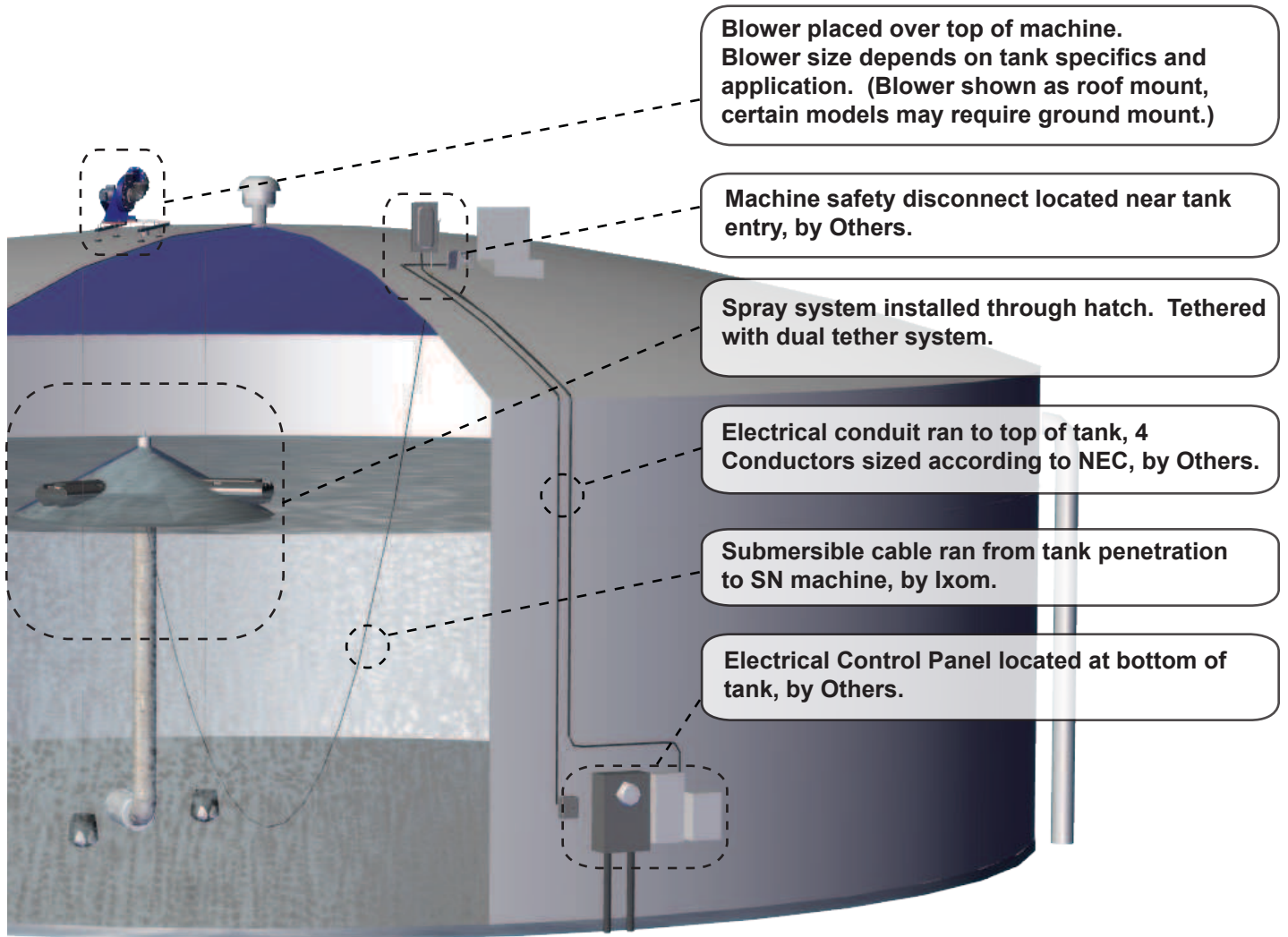

Tethering

Visual Dual Tethering

SN Large Frame Series

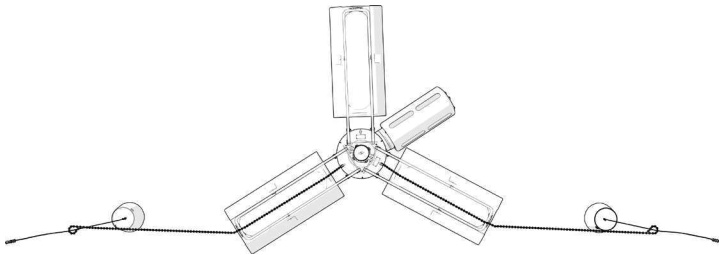

TOP VIEW SN DUAL TETHERING

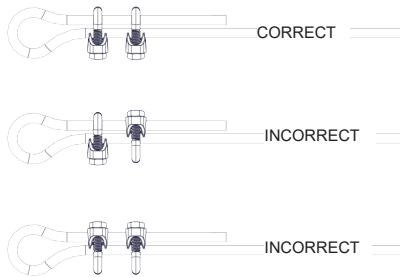

CABLE CLAMP DETAIL

CONCRETE ROOF
 * Anchor provided by Contractor / Tank Manufacturer

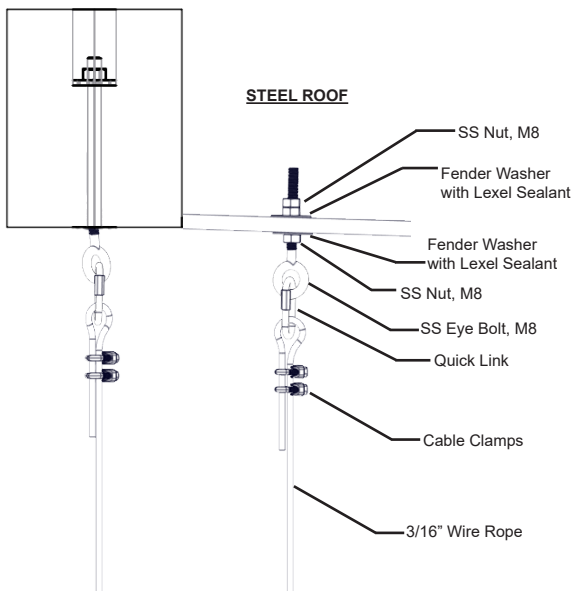

ROOF CONNECTION DETAIL

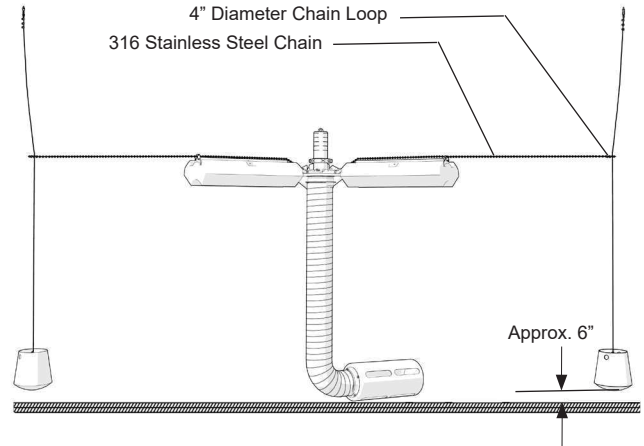

FRONT VIEW SN DUAL TETHERING

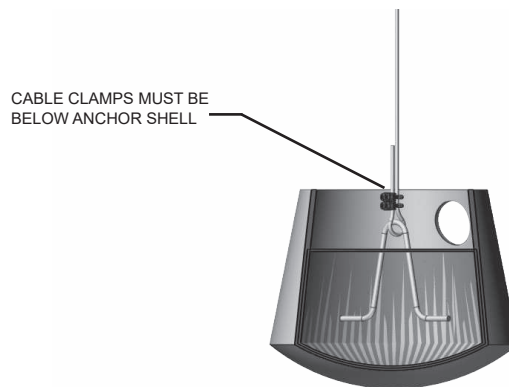

MOORING BLOCK CONNECTION DETAIL

Large Frame Assembly

SN10 / SN15



SN Large Frame

Assembly Diagram

IMPORTANT! The following pages give detailed instructions on how to assemble different portions of the machine; however, the order in which the components are assembled and entered into the reservoir may need to be altered based on tank access and whether the reservoir will be full or empty. For instance, the intake hose assembly to the top frame and float assembly can be performed on the reservoir exterior prior to lowering the equipment inside if the hatch has a clear opening of at least **36 inch diameter (90cm)**. A hatch this size or larger will allow the SN10/SN15 collapsible unit assembly to be placed without float disassembly. For smaller hatches, **minimum 24" square**, the SN10/SN15 collapsible unit assembly will need to be broken down into multiple components and the hose assembly may need to be performed inside the reservoir. The following order of operations listed is based on a wet placement and small hatch opening.

Large Frame Assembly

SN10 / SN15

SN Large Frame

Assembly Diagram

Hose & Intake Box Assembly (See Figures 1 & 2)

TOOLS REQUIRED

5/16" Nut Driver for Hose Clamps • 13mm Wrench and Socket Wrench

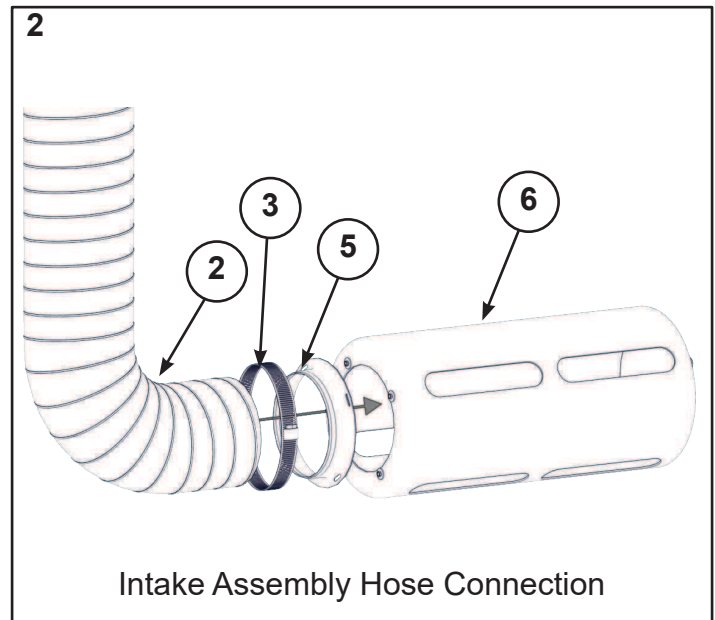
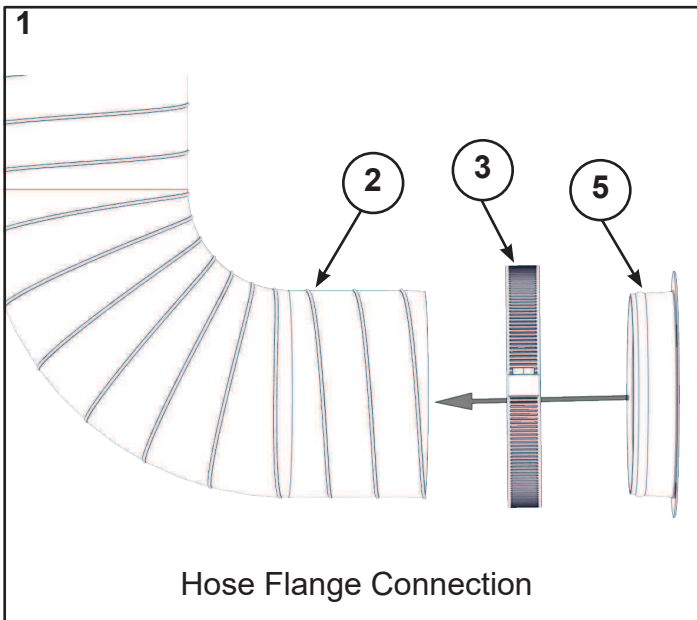

STEP 1: Locate one end of the hose section and place hose clamp over the end, and insert a hose flange. Be sure the hose and clamp are placed above the metal rib of the flange and then tighten hose clamp as tight as possible to firmly secure hose. Repeat on opposite end of the hose section.

(See Figure 1)

STEP 2: If multiple sections of hose are required, repeat step 1 for each section of hose. Fasten the hoses together by bolting two flanges using four M8 x 20mm bolts.

STEP 3: Fasten opposite end of the hose assembly to the intake box using four M8 x 20mm bolts.

(See Figure 2)

STEP 4: Fasten one end of the hose assembly to bottom of the platform assembly securing the flange to the platform assembly using four M8 x 20mm bolts to the center hole of the float arm bracket.

(See Figure 3)

Large Frame Assembly

SN10 / SN15

SN Large Frame

Assembly Diagram

Platform Frame & Pump/Motor/Nozzle Assembly (See Figures 3 & 4)

The four float arm brackets are typically already attached to the top frame. In cases of small hatch openings, the floats may need to remain detached from the top frame and assembled inside the tank.

A minimum Ø36" opening is required when floats are attached to the top frame.

TOOLS REQUIRED:

13mm Wrench • 13mm Socket Wrench • 1 1/8" Wrench • 1 1/8" Socket Wrench • Food-Grade Silicone Lubricant

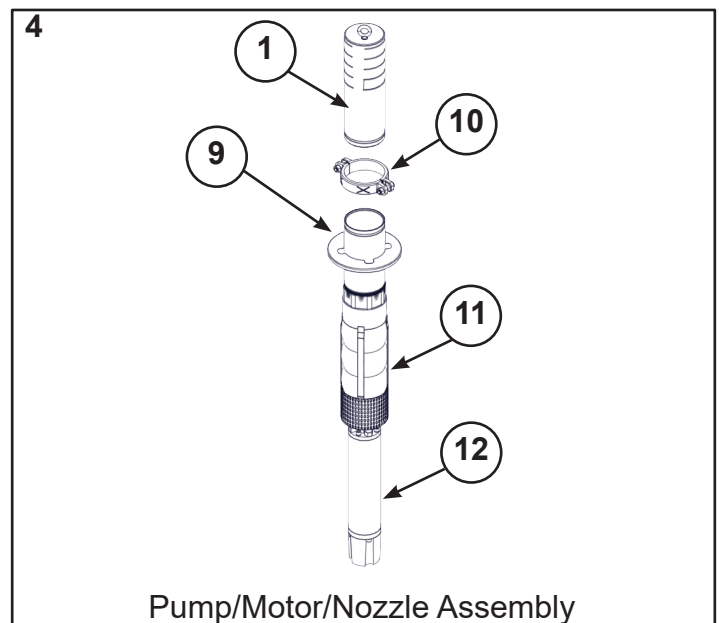
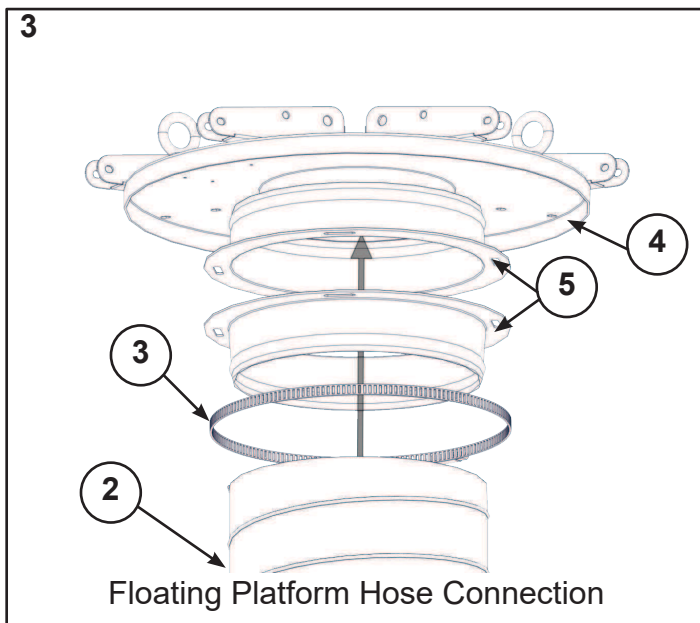

STEP 1: If not already completed in the previous hose assembly steps, connect the intake hose to the platform assembly and float arm brackets using the center hole of the float arm bracket.

STEP 2: Locate the nozzle assembly, 6" groove coupling, and pump/motor assembly. **(See Figure 4)**

STEP 3: Securely support the pump/motor assembly so the pump discharge pipe is at least 12" from the work surface. It may be helpful to have an extra hand in the following steps.

STEP 4: Apply the silicone lubricant on the inside of the groove coupling. Slide the coupling on the end of either the nozzle or the pump discharge pipe.

STEP 6: Place the nozzle on the pump discharge pipe and slide the coupling centered of the seam. Place the groove coupling and ensure the coupling is seated into the grooves of the nozzle and pump discharge pipe.

STEP 7: Tighten the groove coupling, alternating bolts a couple times during the process to ensure an even clamping force around the pipe.

Alternative Option: The nozzle can also be attached to the pump/motor assembly after the SN unit is placed and floating in the tank.

Large Frame Assembly

SN10 / SN15

SN Large Frame

Assembly Diagram

Equipment Entry Through Hatch (See Figures 5 & 6)

Depending on the hatch size configuration and type of reservoir, more equipment assembly may be possible outside the reservoir prior to passing the equipment through the hatch. The following order for lowering equipment down is recommended for a wet placement once an entrant has safely entered the tank and is ready for interior assembly.

TOOLS REQUIRED

Pliers • 13mm Wrench • 13mm Socket Wrench • Large Crescent Wrench
Equipment Hoisting Tools / Rescue Equipment

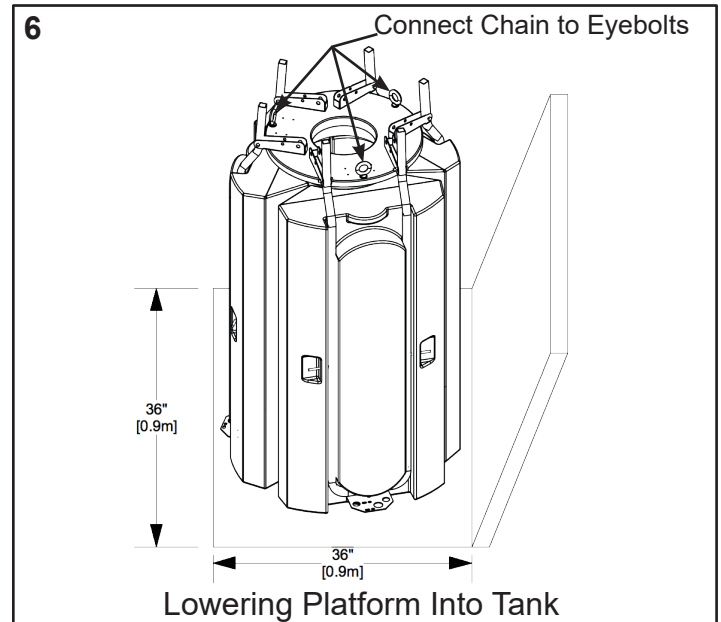
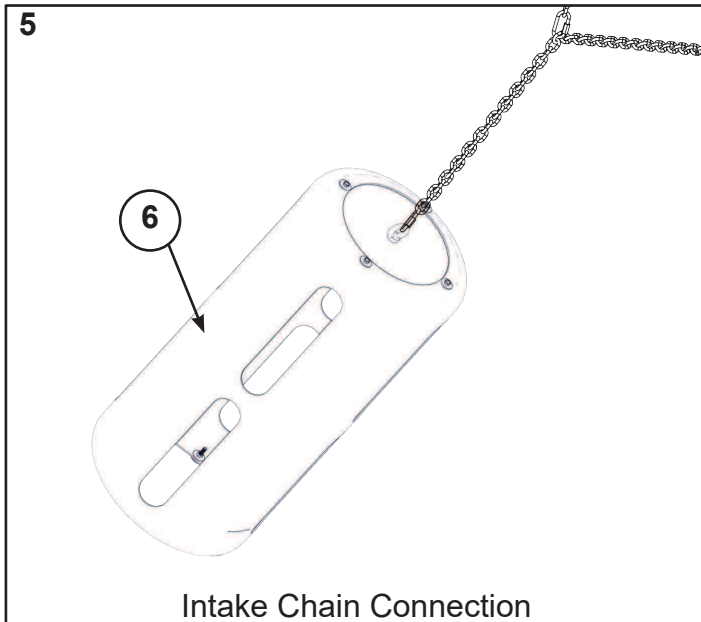

STEP 1: Attach the hose chain to the eye bolt on the end of the intake box. A small section can be cut from the hose chain, attaching the hose chain to the second eyebolt, or double back the chain to one of the eyebolts in order to connect to both eyebolts of the intake box. (See Figure 5)

STEP 2: Lower the intake box through the hatch. It may be a good idea to have a float ball temporarily attached to the end of the hose chain for easy retrieval later.

STEP 3: Continue to lower the unit until the top frame and floats are deployed and floating at the surface. (See Figure 6)

IMPORTANT: The next steps will require equipment to hold the unit in position and lower it down in a slow, controlled manner.

Large Frame Assembly

SN10 / SN15

SN Large Frame

Assembly Diagram

Float Arm Assembly (See Figures 7 & 8)

TOOLS REQUIRED

13mm Wrench • 13mm Socket Wrench

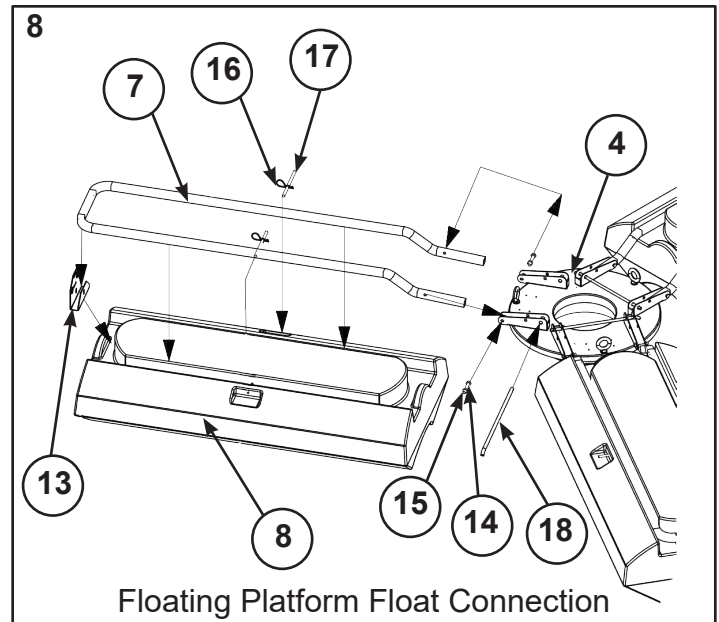
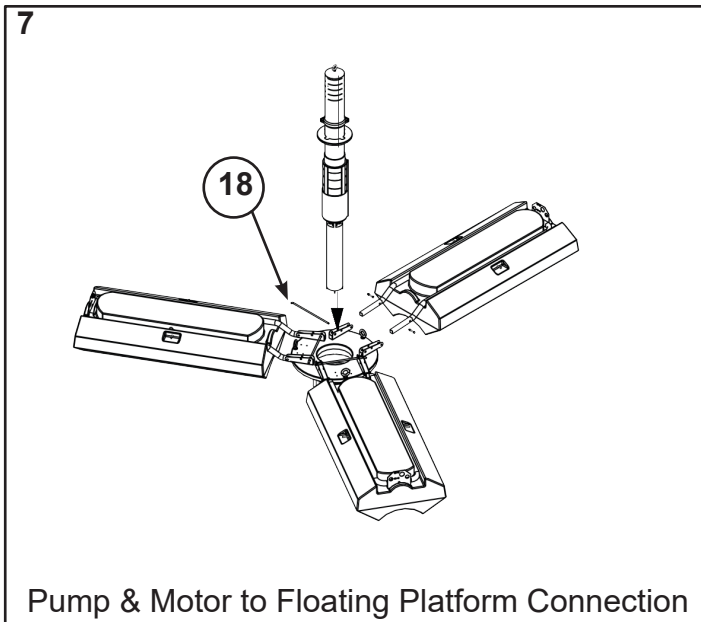

The following steps are for attaching the SN drive assembly to the floating platform assembly.

- STEP 1:** Locate the pump/motor/nozzle assembly, (from this point forward this assembly will be called the SN drive assembly). If the floats have been previously attached and the SN drive assembly has not been attached you will need to remove the pins in the float arms to attach the SN drive assembly. (See Figure 7)
- STEP 2:** Lower the SN drive assembly into the floating platform, stabbing the SN drive assembly in through the center opening and into the hose.
- STEP 3:** After the motor/pump/nozzle assembly is resting on the platform re-insert the pins that were taken out in Step 1. (See Figure 8)
- STEP 4:** Locate the end of the intake hose chain. If possible it is preferred to attach the intake hose chain at the hatch if within chain length, otherwise attach at the top frame to one of the lifting points.
- STEP 5:** With the SN Unit floating inside the tank, the unit can now be positioned in the desired location inside the tank.

Large Frame Assembly

SN10 / SN15



SN Large Frame

Tethering Assembly

Vertical Anchor Line Placement (See Figures 9-14)

During operation, the SN10/SN15 will have a tendency to move given the forces of the spray leaving the nozzle. The unit needs to be restrained horizontally, therefore the unit will need to be loosely tethered to vertical anchor lines to hold it in place at varying water levels.

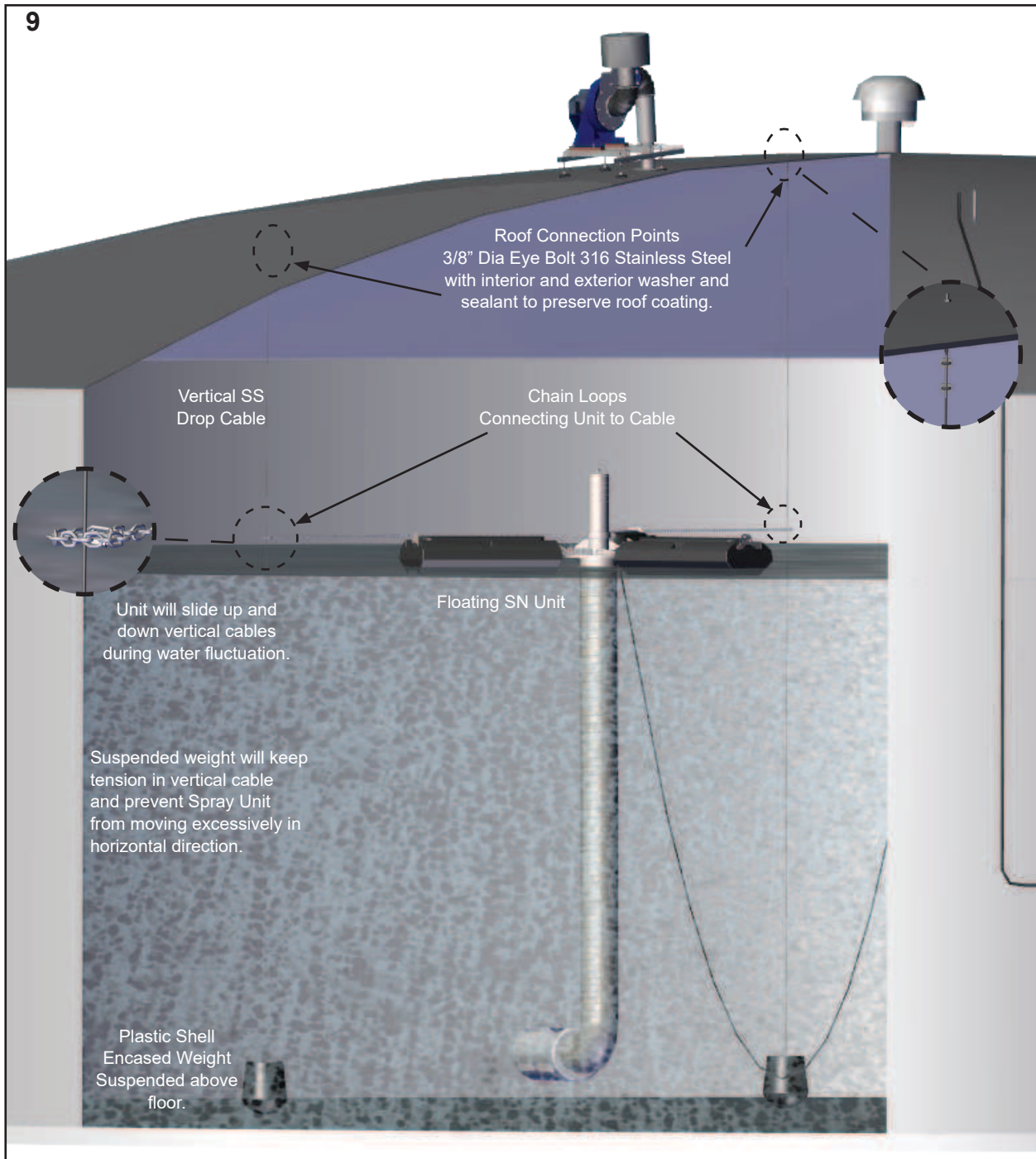

Large Frame Assembly

SN10 / SN15



SN Large Frame

Tethering Assembly

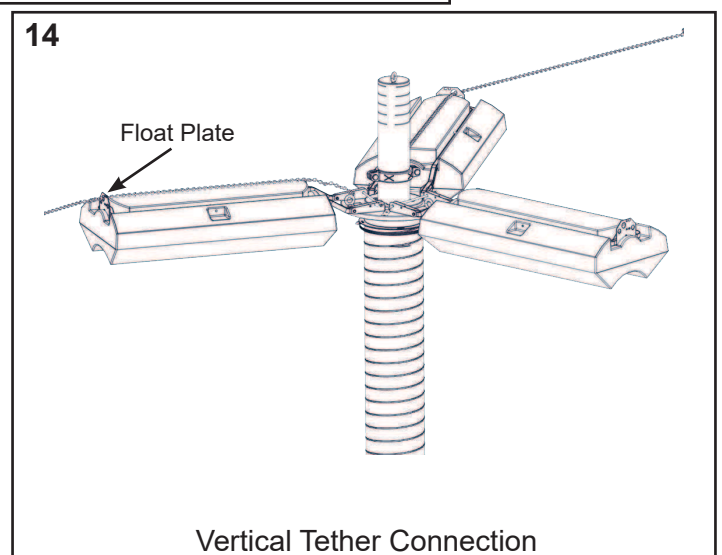
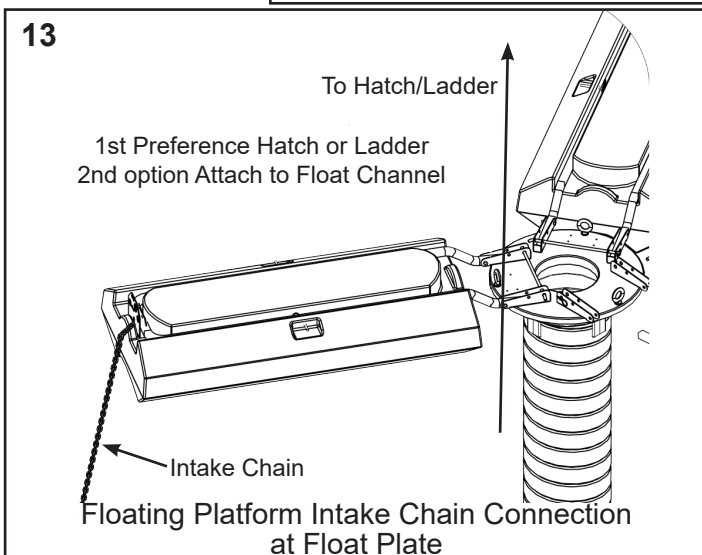
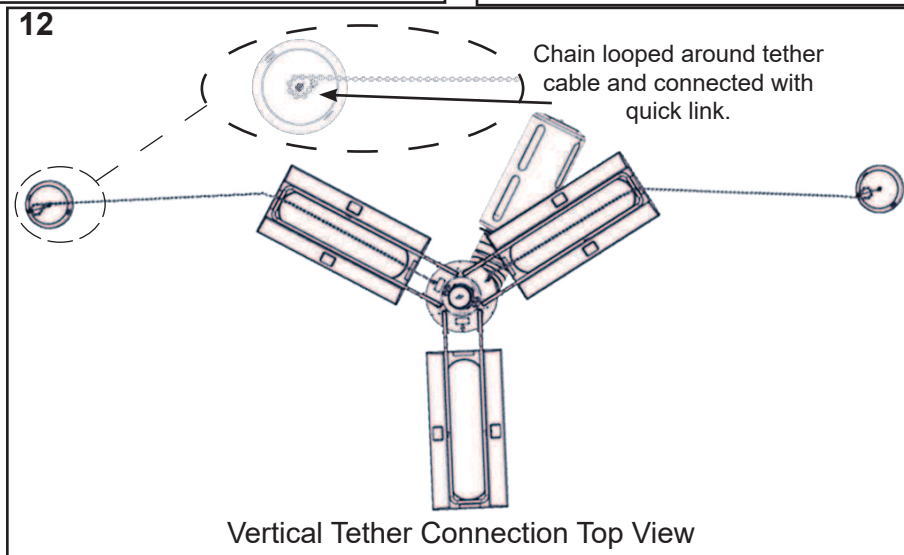
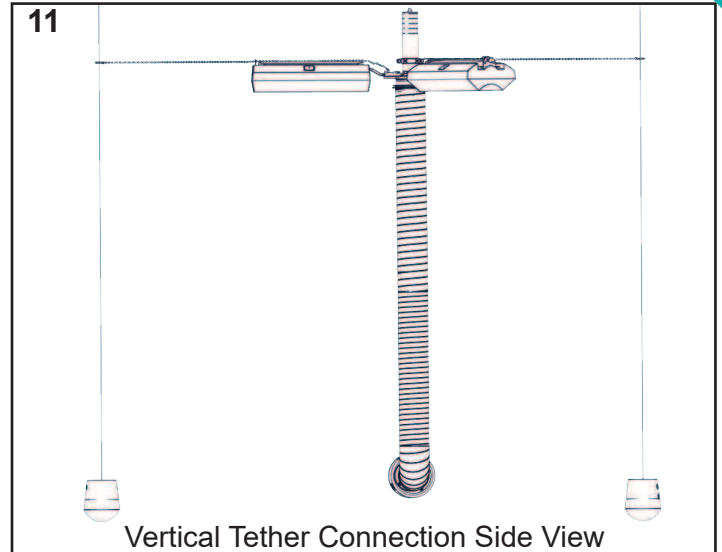
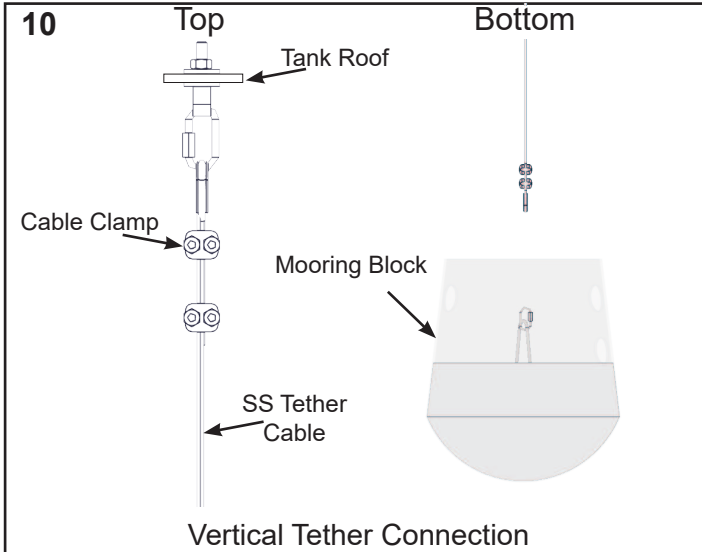

SN Units Electrical Wiring

Power Connection - Motor and control wiring, overload protection, disconnects, accessories and grounding should conform to the National Electrical Code and local codes and practices.

During factory placement, the submersible power cable from the submersible motor will be terminated at the roof of the reservoir. This will be the point of hand off for the electrician to bring power to.

Electric Cable Routing

Depending on the roof construction, various methods of providing a sealed electric cable penetration will be required. The following steps offer an example of a sealed fixture penetration available for steel and aluminum roofs.

- STEP 1:** Find a suitable location near the hatch and mark a penetration point on the roof for the through tank fitting that the electric cable will pass through. When selecting a penetration location through the roof, be sure to confirm the following:
- A.** The penetration is not going to interfere with internal obstructions, (i.e. roof beams, cathodic systems, etc.)
 - B.** The penetration is centered within a clear footprint of approximately 8-inch X 8-inch (20cmX20cm)
 - C.** The penetration can be accessed on the inside of the tank when reaching from the hatch.
- STEP 2:** Use a cordless drill with the 1-5/16 inch (33mm) hole saw provided and begin drilling a hole through the tank roof. A small amount of food grade vegetable oil works well for lubrication of the hole saw. Prior to completing the penetration, position a container or catch net below the penetration point to catch filings and the hole cut out.
- STEP 3:** Remove all filings and thoroughly clean all surfaces around the penetration before removing the catch net. The penetration is now ready for a sealant application and placement of the Through Tank Fitting.
- STEP 4:** Apply a healthy amount of LEXEL brand sealant provided on all the surrounding surfaces of the penetration (interior, exterior, and inner wall). This will prevent future corrosion of the roof around the fixture.

T316 SS CORD BOLT: TANK PENETRATION ASSEMBLY

TANK PENETRATION IS SEALED WITH HDPE WASHERS ACCOMPANIED BY LEXEL® CO-POLYMER RUBBER-BASED SEALANT

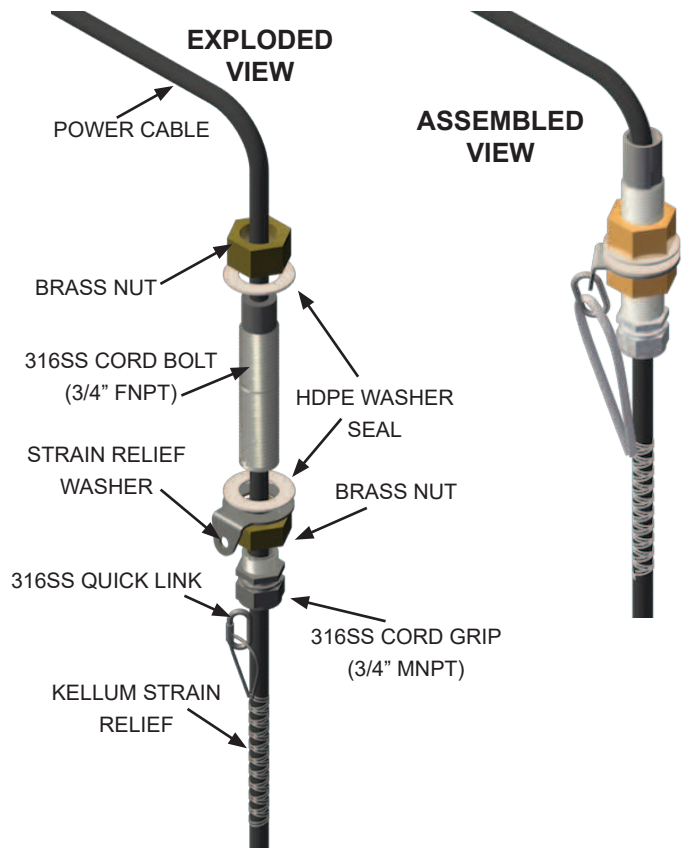
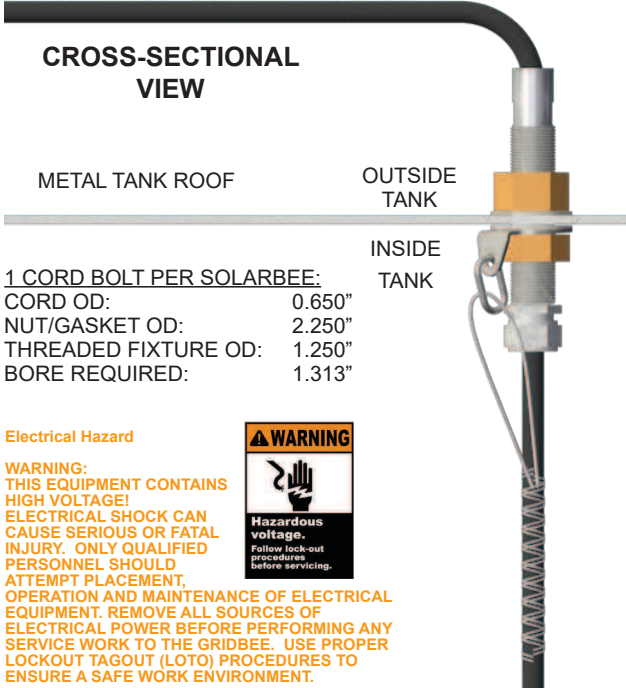

Electrical

SN Units Electrical Wiring

Electrical Connection

Below is the epoxy splice for making a water-tight sealed electrical connection. The electrical splices may have already been done. If so, the below steps can be skipped.

TOOLS REQUIRED:

Electrical Splice Crimp/Stripping Tool
Caulking Gun

STEP 1: Cut back outer jacket about 2 inches, Caution do not nick jacket of the inner wire. Off set/stagger the inner wires, and strip ends. *(See Figure 1)*

STEP 2: Place metal crimp around the wires, crimp and place protective cover over crimp. *(See Figure 2)*

STEP 3: Take pvc sleeve and fill half way with epoxy. Push wires all the way to the bottom to ensure crimps are covered with epoxy. *(See Figure 3)*

STEP 4: Fill remaining gap with epoxy and plunge wires to remove air from the epoxy. *(See Figure 4)*

Note: Epoxy has roughly 1-hr set time at 60 degrees. During this time, try to ensure the splice is upright so no epoxy can spill out.

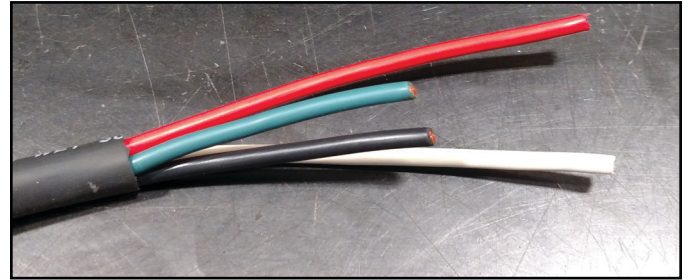

Figure 1

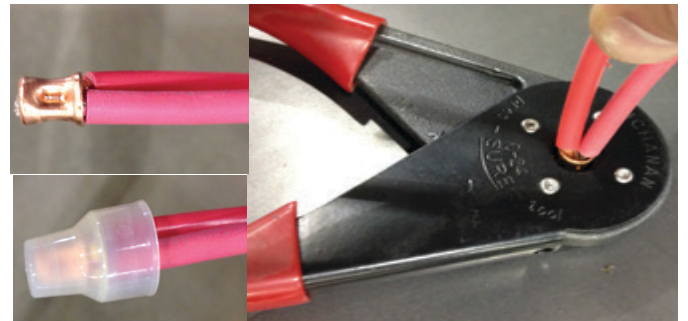

Figure 2

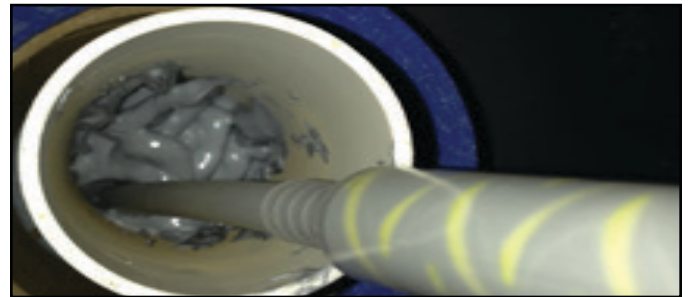

Figure 3



Figure 4



Epoxy Electrical Splice Kit

Three Phase Wiring for THM SN Spray Units

Three Phase Motor Specifications (60 Hz) 3450 RPM:

TYPE	RATING					FULL LOAD		MAXIMUM LOAD		LINE TO LINE RESISTANCE OHMS	EFFICIENCY		LOCKED ROTOR AMPS	KVA CODE
	HP	KW	VOLTS	HZ	S.F.	AMPS	WATTS	AMPS	WATTS		S.F.	F.L.		
4" STD	5	3.7	200	60	1.15	18.3	4800	20.5	5500	.68-.83	78	78	116	K
			230	60	1.15	15.9	4800	17.8	5500	.91-1.1	78	78	102	K
			460	60	1.15	7.5	4800	8.6	5500	3.6-4.4	78	78	53.7	K
6" STD	10	7.5	230	60	1.15	28.4	9400	32.2	10800	.47-.57	79	79	172	H
			380	60	1.15	17.6	9400	19.6	10800	1.2-1.5	79	79	104	H
			460	60	1.15	14.2	9400	16.1	10800	1.9-2.4	79	79	86	H
6" STD	15	11	380	60	1.15	25.8	13700	28.9	15800	.77-.95	81	81	161	H
			460	60	1.15	20.8	13700	23.7	15800	1.1-1.4	81	81	133	H

TYPE	RATING			CIRCUIT BREAKERS OR FUSE AMPS			CIRCUIT BREAKERS OR FUSE AMPS		
				(MAXIMUM PER NEC)			(TYPICAL SUBMERSIBLE)		
	HP	KW	VOLTS	STANDARD FUSE	DUAL ELEMENT TIME DELAY FUSE	CIRCUIT BREAKER	STANDARD FUSE	DUAL ELEMENT TIME DELAY FUSE	CIRCUIT BREAKER
4" STD & HI-TEMP	5	3.7	200	60	35	50	60	25	50
			230	50	30	40	45	20	40
			460	25	15	20	25	10	20
6" STD.	10	7.5	230	90	50	80	90	40	80
			380	60	35	45	50	25	45
			460	45	25	40	45	20	40
6" STD.	15	11	380	80	50	70	80	35	70
			460	70	40	60	60	30	60

Three Phase Submersible Motor and Pump Protection Wiring

Base Unit



- ① Voltage Inputs (L1, L2, L3)
- ② Integrated Sensor Coils
- ③ Insulation Check Connection
- ④ Test/Reset Switch
- ⑤ Fault Light (Base)
- ⑥ Bluetooth Pairing QR Code
- ⑦ Control Circuit Terminals
- ⑧ Input/Output Terminals

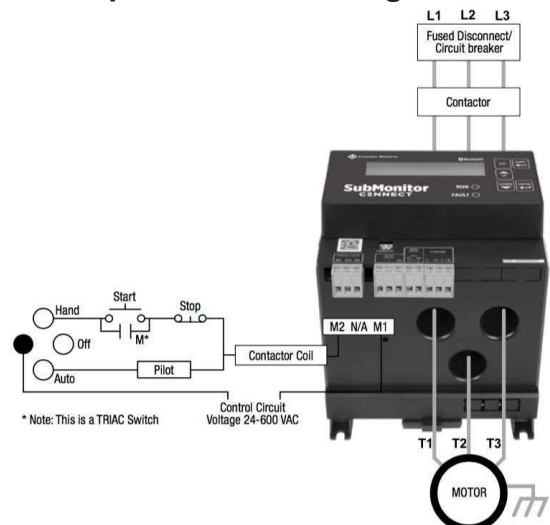

Electrical

Universal Fixture Assembly

Tank Penetration Assembly

TANK PENETRATION IS SEALED WITH HDPE WASHERS ACCOMPANIED BY LEXEL® CO-POLYMER RUBBER-BASED SEALANT

1 CORD BOLT PER GRIDBEE:

NUT/GASKET OD: 2.250"
THREADED FIXTURE OD: 1.250"
BORE REQUIRED: 1.3125"

CROSS-SECTIONAL VIEW

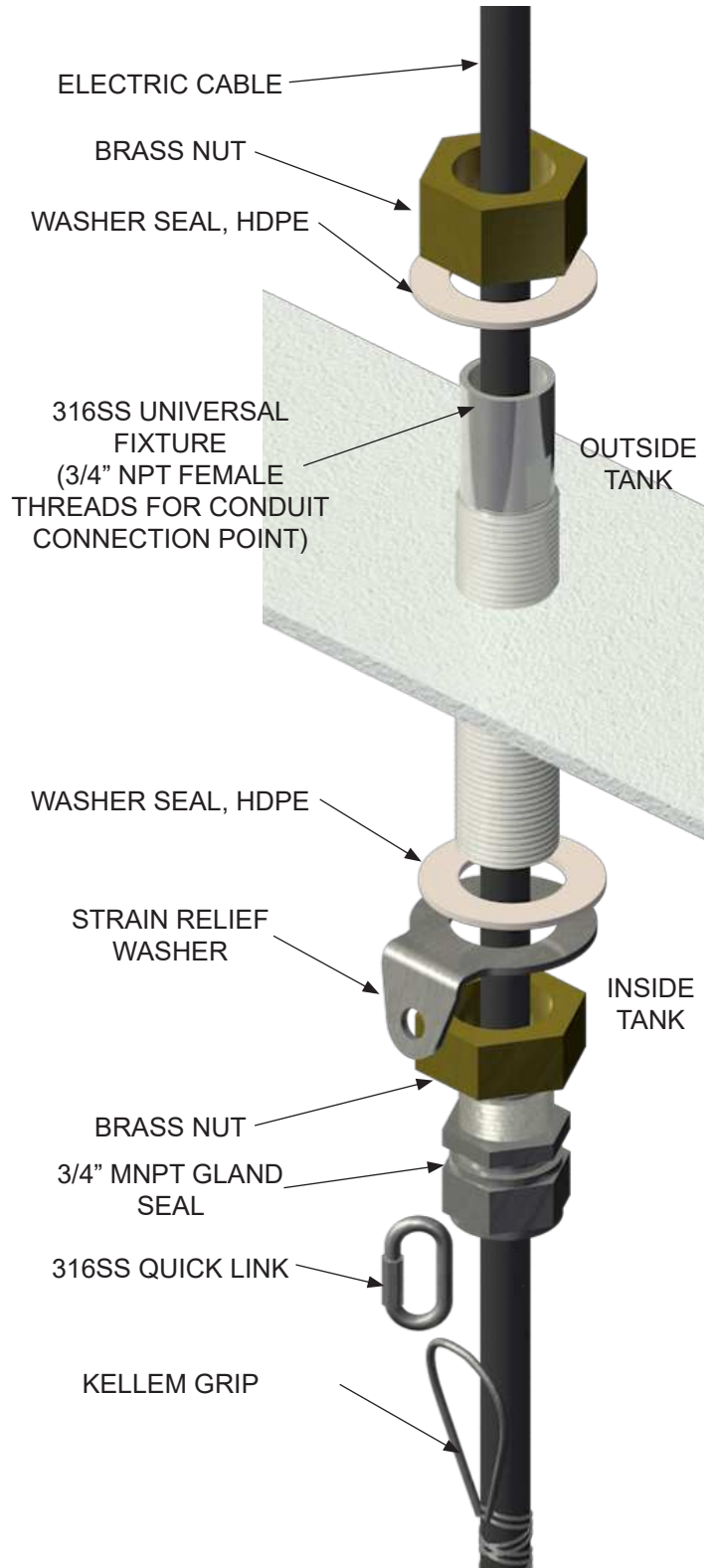
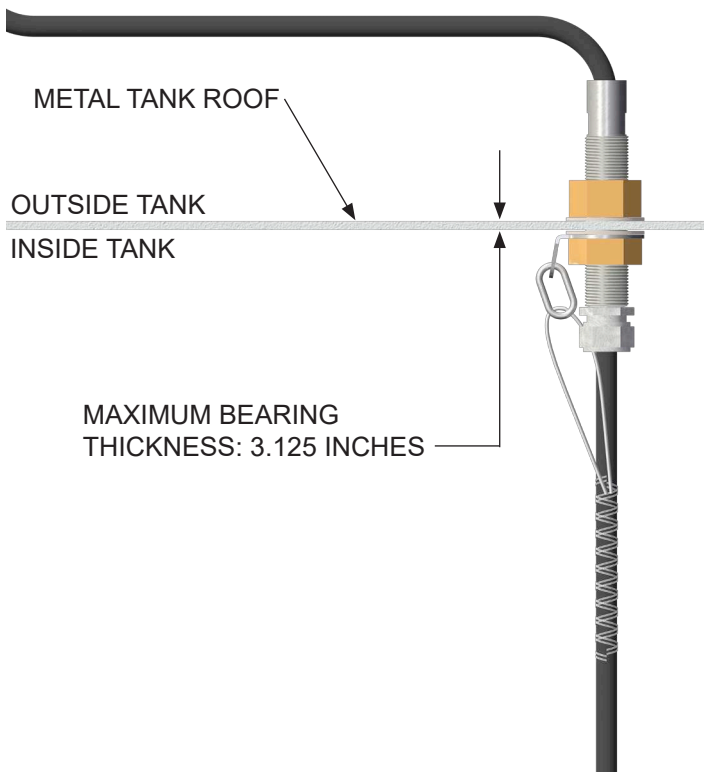

NOT DESIGNED AS A SUBMERSIBLE PENETRATION.

Startup and Operation

SN Startup and Operation

Wiring

Placement Checks

Before starting the SN Spray Unit a few checks need to be done to confirm the placement is correct.

Placement Check	Check
Is the SN Spray Unit properly tethered? (Assembly)	
Is the cord ran through the cord seal and cord seal tightened at the interior of the cord fixture? (Assembly)	
Is the top splice between submersible cable conductors and exterior electric conductors insulated from each other and individually sealed to protect from corrosion? (Assembly)	
Is the control panel wired correctly? (Control Panel Diagram)	
Is the SN Spray Unit submerged within the minimum water depth required? (Technical Specifications)	
Is the Motor rotating the correct direction? (See Rotation Check below)	

Final Checks

Now that the install checks have been completed. Now to confirm the continuity and discontinuity and then start the SN Spray Unit.

Check	Reading			
	Single Phase	Three Phase		
Continuity Check (Motor Windings + Splice + Wire) Reference Wiring for Line to Line Ohms	L1:L2	L1:L2	L2:L3	L1:L3
Discontinuity Check (Power to Ground) Should be Open to Ground	L1: GND	L1: GND	L2:GND	L3:GND
Source Voltage Reading (while unit is running)	L1:2	L1:2	L2:L3	L1:L3
Amperage Reading (while unit is running) Reference Wiring Full Load / Max Load	L1	L1	L2	L3
Flow Check Auditory				
Flow Check Visual				

Rotation Check - (Three Phase Only)

Before finalizing the placement, the motor rotation needs to be checked. With someone observing the SN Spray Unit, briefly turn the unit on for several seconds and observe the flow pattern, look for how far out the spray reaches. Turn unit off, isolate power, and have a qualified person switch 2 of the 3 motor leads of outgoing power. Repeat operation again for several seconds and observe the SN Spray Unit flow pattern again. Determine which wiring configuration produced the flow pattern that reaches out the furthest and finalize with that wiring of the outgoing power leads. See Figure 1 for proper flow direction.

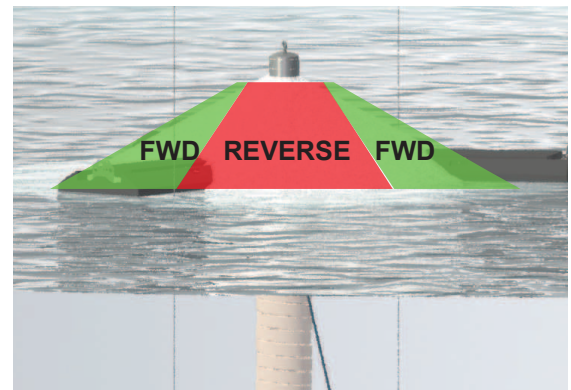

Figure 1: Flow Check

SN Troubleshooting - Wiring

Operation

For suspected issues regarding SN Spray Unit operation, observing and recording motor current and voltage during operation is a good starting point. The normal operating values can be referenced from initial Startup & Operation records and/or from the Wiring document. In addition to motor voltage and current measurements, with power isolated, continuity (ohm) value measurements are helpful in pinpointing issues.

Check	Reading			
Flow Check Visual				
Flow Check Auditory				
<i>Electric measurements should only be performed by qualified personnel</i>	Single Phase	Three Phase Only		
Source Voltage Reading (while unit is running)	L1:L2	L1:L2	L2:L3	L3:L1
Amperage Reading (while unit is running) Reference Wiring Full Load / Max Load	L1	L1	L2	L3
Continuity Check (Motor Windings + Splice + Wire) Reference Wiring for Line to Line Ohms	L1:L2	L1:L2	L2:L3	L3:L1
Discontinuity Check (Power to Ground) Should be Open to Ground	L1: GND	L1: GND	L2:GND	L3:GND

Symptom	Possible Issue / Remediation
Motor Amperage is low	Blocked pump inlet screen, clean debris from inlet Blocked spray nozzle(s), clean spray nozzle(s) Broken, severely worn coupling between pump and motor, pump and/or motor replacement
Motor Amperage is high	Low / Unbalanced line voltage, check source power Phase loss, check source power Short to ground, check continuity to ground leads, bad electric cord, splice, or motor failure, replace faulty component(s) Motor or pump failure, replace motor and/or pump
Fault Message from Three-Phase Motor Protection device	Reference motor protection device manual for detailed problems/conditions resulting in fault message.

Rotation Check - (Three Phase Only)

If wiring was disconnected during troubleshooting steps, the motor rotation needs to be checked. With someone observing the SN Spray Unit, briefly turn the unit on for several seconds and observe the flow pattern, look for how far out the spray reaches. Turn unit off, isolate power, and have a qualified person switch 2 of the 3 motor leads of outgoing power. Repeat operation again for several seconds and observe the SN Spray Unit flow pattern again. Determine which wiring configuration produced the flow pattern that reaches out the furthest and finalize with that wiring of the outgoing power leads. See Figure 1 for proper flow direction.

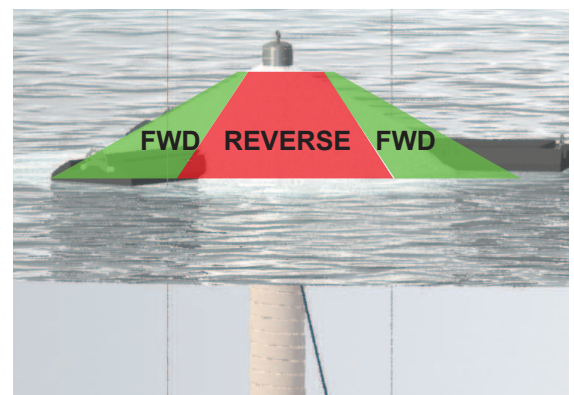

Figure 1: Flow Check

SN10

Technology Description- Floating, electric powered, circulation and Trihalomethane (THM) removal equipment for potable water tanks and reservoirs. Designed for continuous operation and factory installed through 24-inch diameter, clear and unobstructed hatch opening.

Materials of Construction - T316 stainless steel, thermoplastic rubber, high density polyethylene construction. GridBee® machines are constructed using safe materials for contact with potable water. See certifications section below.

TTHM Reduction Range - 20% to 70%, dependant on THM species, daily inflow and other variables, see Ixom for proposal.

Spray Unit Direct Flow Rate - 0.90 million gallons per day, MGD. *Ixom application engineering evaluations often require sizing systems based on site specific conditions and NOT the spray aeration direct flow rate.*

Minimum Access Opening - Machine can be placed through 24-inch (61cm) diameter, clear and unobstructed hatch opening.

Minimum Water Depth - Minimum of 5ft (1.5m) operating depth required, do not operate out of water. Minimum of 6.25ft (1.9m) depth required with leg extensions.

Minimum Head Space - Minimum of 30in (76cm) head space between water level and reservoir/tank ceiling required. **(Contact Ixom for exceptions that can be made.)**

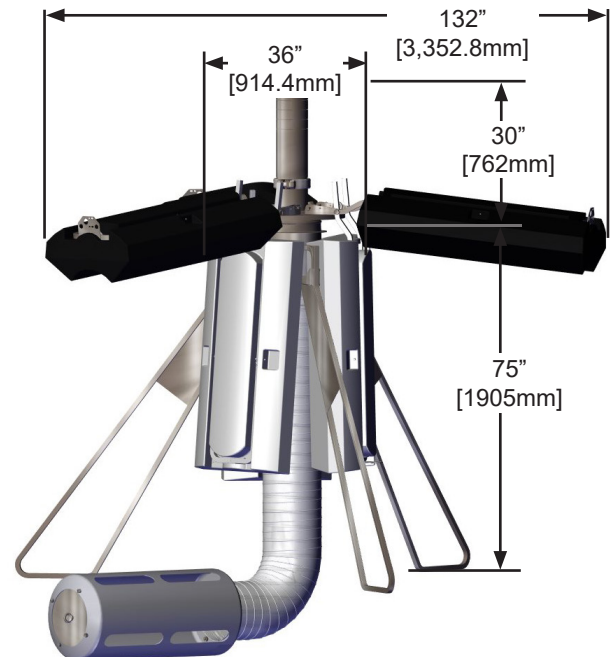

Figure 1: SN10

Intake - 20 to 100+ feet (6 to 30+ m) available in 12-inch (30.5 cm) diameter X 20 feet (6 m) sections, thermoplastic rubber, NSF/ANSI 61 approved. Includes low elevation intake that draws water in a horizontal layer within 18 inches (45 cm) of the tank or reservoir floor. Includes intake retrieval chain constructed of 316 stainless steel.

Electrical Requirements - Requires 240VAC/3PH or 480VAC/3PH, 60Hz power. Ixom recommends secondary disconnect to be located near equipment access hatch. Optional Franklin SubMonitor three-phase motor protection unit highly recommended and available from Ixom. *All switches, breakers, emergency stop buttons, control panels and other controls shall be installed in accordance to all NEC, State, and local regulations. (Not supplied by Ixom)*

Motor - 10HP stainless steel submersible, designed for continuous operation, low power requirement, direct drive, no gearbox and no lubrication schedule required. See certifications section below.

Wiring - 4-conductor, submersible power cable for submersible motor wiring terminated exterior at top of tank.

Sealed Penetration Fitting - T316 stainless steel tank fitting with a 3/4" NPT female connection. Not designed as a submersible penetration.

Shipping Size / Weight

• **Crate** - 72in x 48in x 59in (1.85m x 1.22m x 1.5m) / 1200lbs (550kg) *Exact weight and dimensions varies dependent on machine configuration.*

Certifications - Ixom's potable water products are certified to NSF/ANSI/CAN 61-G & 372 for lead-free content. Learn more at: www.ixomwatercare.com/std61

Maintenance / Warranty - Limited maintenance. Limited 2-year parts and labor warranty. See Warranty Statement for details.

Patent Pending

Subject to change without notice.

Exploded Parts Diagram

SN10

Exploded Parts Diagram

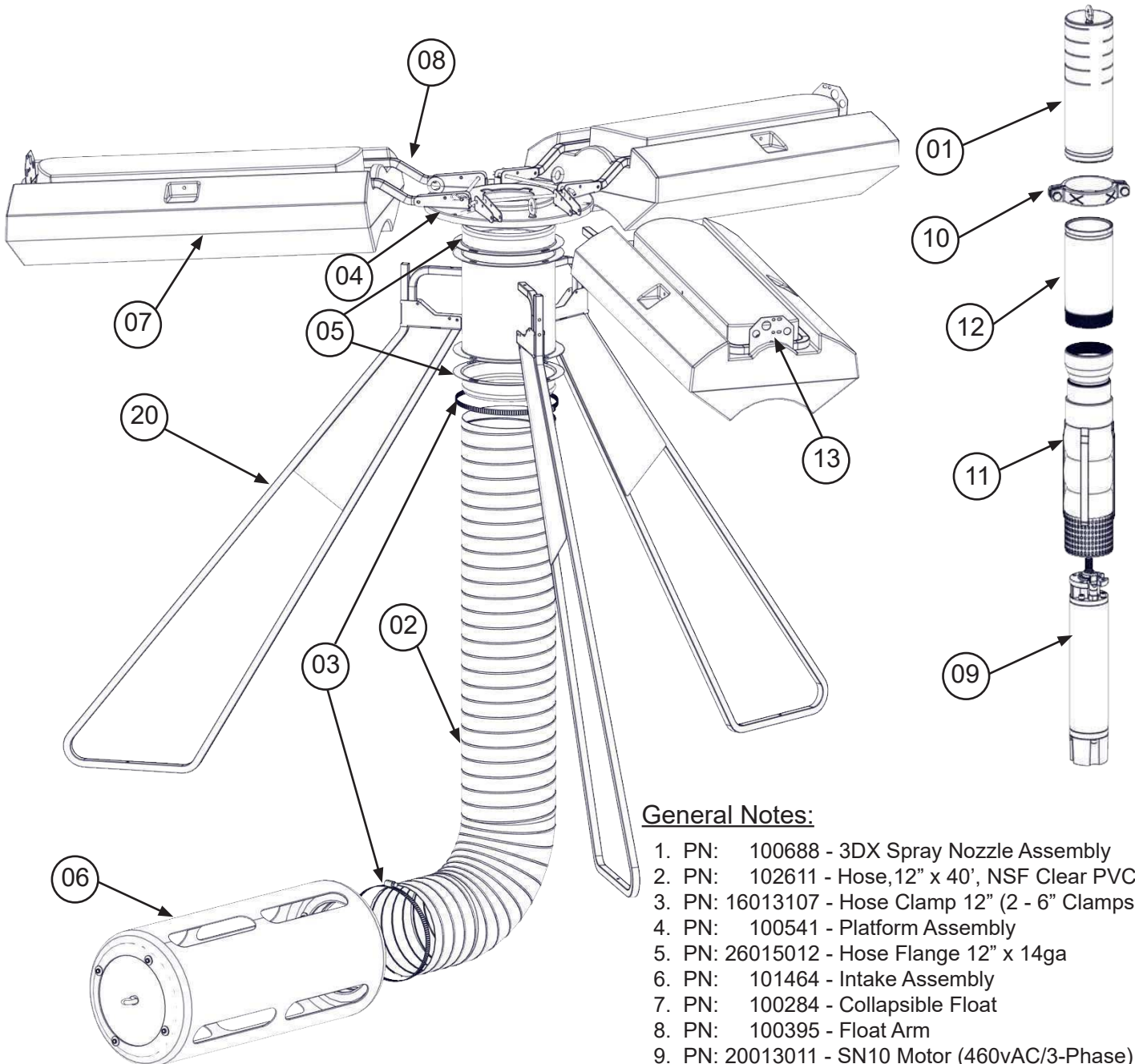

General Notes:

1. PN: 100688 - 3DX Spray Nozzle Assembly
2. PN: 102611 - Hose, 12" x 40', NSF Clear PVC
3. PN: 16013107 - Hose Clamp 12" (2 - 6" Clamps)
4. PN: 100541 - Platform Assembly
5. PN: 26015012 - Hose Flange 12" x 14ga
6. PN: 101464 - Intake Assembly
7. PN: 100284 - Collapsible Float
8. PN: 100395 - Float Arm
9. PN: 20013011 - SN10 Motor (460vAC/3-Phase)
10. PN: 16013206 - Groove Coupling 6"
11. PN: 20013012 - SN10 Pump
12. PN: 100211 - Discharge Pipe 6"
13. PN: 100446 - Universal Float Plate
20. PN: 101284 - 60" Leg Extension Kit
21. PN: 101967 - Leg Extension Barrel Assembly

Dimension Drawing

SN10

Dimension Drawing

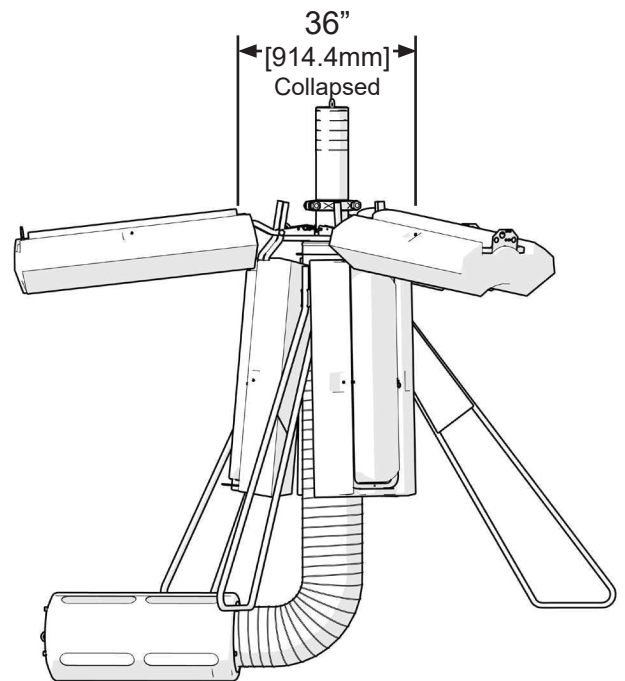
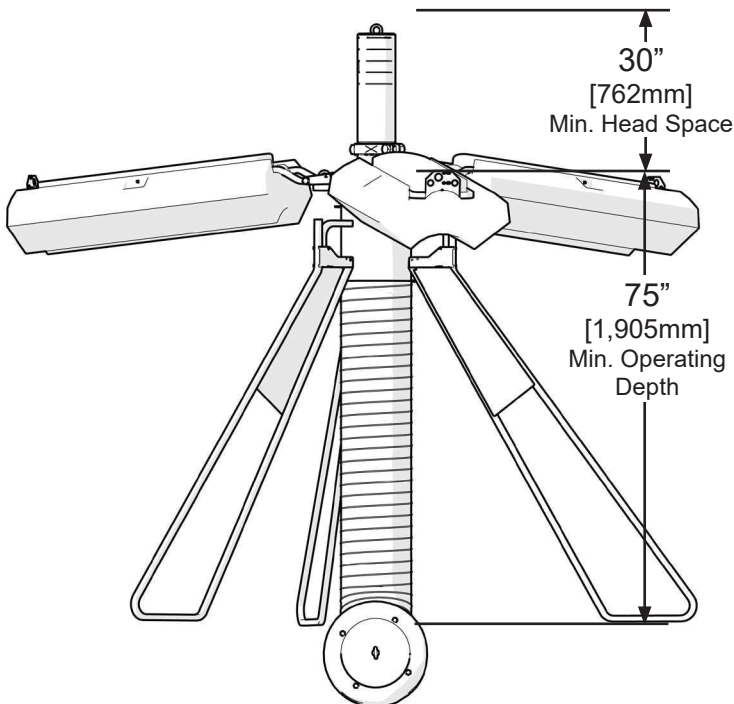
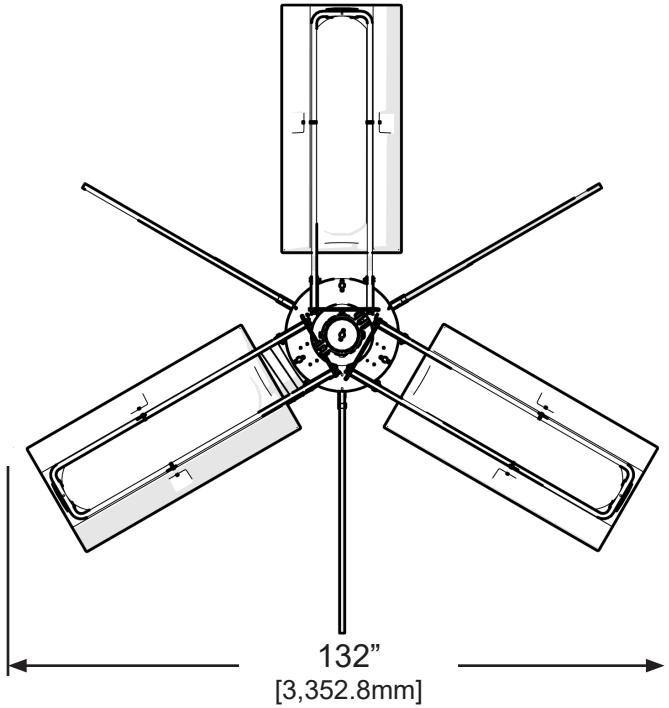

Placement Record



SN Series

Placement Recording

Throughout the placement, recording of various details of the equipment and placement are recommended. This record will serve as a future reference should any equipment issues arise at a later date. The following form is an example of an placement record for this equipment.

<i>DATE</i>	<i>CREW</i>	<i>LOCATION / FACILITY / NAME / CELL # / LOCATION NUMBER</i>
-------------	-------------	--

SPRAY NOZZLE PLACEMENT FIELDSHEET

Spray Unit Model:
Spray Unit SN:
Motor SN:
Pump SN:
Nozzle Type:
Nozzle Type:
Anchoring IF Vertical Cable-Mooring Block, Length of Cable IF other, describe in Notes or separate sheet.

Hose	
Hose Diameter	Hose Length
	top
	bottom
IN TANK ELEC. CORD Length (ft)	
Take Pictures of: Placement Process, Lifting, Spray Unit Placed, Power Panels, Junction Boxes, Tank, Hatches, Safety, Vents, Overflow, Other, Etc.	

AFTER Splice Connection PRIOR To Start Up
Phase 1:2 (Ohms)
Phase 2:3 (Ohms)
Phase 1:3 (Ohms)
Ground: Phase 1 (Ohms)
Ground: Phase 2 (Ohms)
Ground: Phase 3 (Ohms)
AFTER Start Up
Forward Pressure (psi)
Reverse Pressure (psi)
Have Electrician Check
Operating Voltage
Operating Current

NOTES:

Warranty



GridBee THM Removal Systems

Limited Replacement Warranty

GridBee SN Spray Units. GridBee SN Spray Units and blowers are warranted to be free of defective parts, materials, and workmanship for a period of two years from the date of purchase. The optional control panels, by other manufactures, are covered by a manufacturer's warranty of one year from date of purchase. This warranty is valid only for use of the GridBee THM Removal System in accordance with the owner's manual and any initial and ongoing factory recommendations. This warranty is limited to the repair or replacement of defective components only and does not apply to normal wear and tear. If the factory's service crews performed the original on-site placement and startup, then this warranty also includes labor. Where labor is included, in lieu of sending a factory service crew to the site for minor repairs, Ixom may choose to send the replacement parts to the owner postage-paid and may pay the owner a reasonable labor allowance, as determined solely by Ixom, to install the parts. There is no liability for consequential damages of any type. The warranty that is submitted and provided with the purchased equipment is the valid warranty.

GridBee control panels, and any optional accessories. These items are considered "buyout" items for Ixom, and as such include a warranty against defects in material and workmanship for one year from the date of purchase. This warranty covers parts only, not labor. Parts that are determined by Ixom to be defective in material or workmanship under normal use during the one year warranty period will be repaired or replaced. Shipping charges are the responsibility of the customer.

Terms applicable to all equipment. This Limited Replacement Warranty is subject to the terms of Ixom's General Terms and Conditions of Sale. In the event of any inconsistency between the terms of this Limited Replacement Warranty and Ixom's General Terms and Conditions of Sale, the terms of this Limited Replacement Warranty shall prevail to the extent of that inconsistency.

Protect Your Investment With The Ixom Service Program

Comprehensive Damage Repair

Damage which occurs to your Ixom manufactured equipment in the normal course of operation will be repaired or replaced including supply and installation of structural repairs and replacement parts in accordance with Ixom's standard terms & conditions.

Trained & Experienced Service Technicians

The Ixom Service Program allows our customers to take advantage of our highly trained service technicians. We have the equipment, experience and training to ensure the machines are well maintained while following OSHA regulations. Our dedication to safety and high level of training has earned us the prestigious SHARP recognition award time and time again. We have the means to safely service the equipment whether in municipal water tanks, lakes, reservoirs, or wastewater ponds & basins.



Guaranteed Annual Onsite Maintenance

Ixom service personnel will perform a minimum of one (1) onsite equipment inspection & maintenance per yearly term of the service contract including mechanical, structural, and electronic components of Ixom manufactured equipment.

On-Site Crew Response for Critical Application and Operational Service Issues

If service issues arise, the customer may be asked to perform a basic machine inspection and discuss results with Ixom's Customer Service Department. In some cases, the customer may be asked to perform minor tasks (i.e., cleaning, basic troubleshooting, and replacing minor parts). If replacement parts are needed, the factory will ship them out at no cost. For more serious application and service issues, Ixom will dispatch service personnel to resolve the issues onsite.



Removal, Storage, and Redeployment of Equipment

For situations when Ixom equipment needs to be removed, stored, and redeployed, services can be offered at a discounted rate.

Access to On-Staff Water Quality Experts

Ixom employs many experts in the water quality field including specialized areas such as limnology, hydrology, wastewater, biology, and engineering. Our water quality personnel are available for data analysis and troubleshooting when you need it.



Contact us for a quote!

Call +1 866-437-8076 or email us at watercare@ixom.com

IXOM

WATERCARE

Nationwide Installation & Service

EVERYONE DESERVES GREAT CUSTOMER SUPPORT

Ixom Watercare earns customer trust with unparalleled service start to finish. Every department in Ixom is dedicated to the support of our Customers and the improvement of water quality. Complete life cycle support is much, much more than a returned phone call or an email. It centers around direct access and communication to those who can help when help is needed from the beginning of a project throughout the life of the equipment.

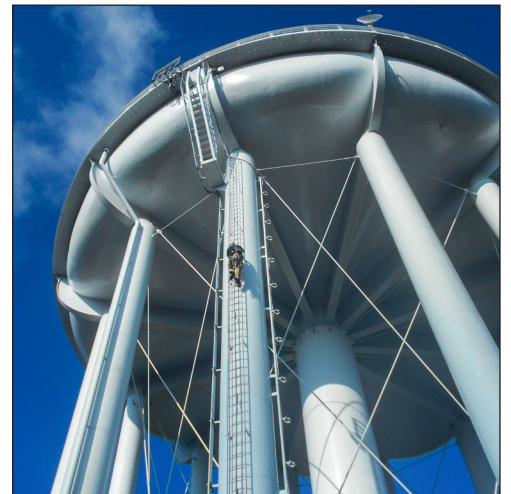

ABOUT IXOM

Ixom combines innovative water quality solutions with top notch manufacturing and nationwide in-field service capabilities to create trusted, full circle support our Customers depend on.

We design and manufacture many trusted brands including GridBee®, SolarBee®, MIEX®, and ResidualHQ® for use across the water quality spectrum. This includes solutions for Water Treatment, Distribution Treatment, Wastewater Treatment and Lakes & Source Water Reservoirs.

Ixom has thousands of installations and is an industry-leader solving water quality problems across the United States, Canada and the world.

Contact us today to discuss your water quality and service needs.

ixomwatercare.com
866-437-8076 • watercare@ixom.com