

GridBee SN5

Owner's Manual

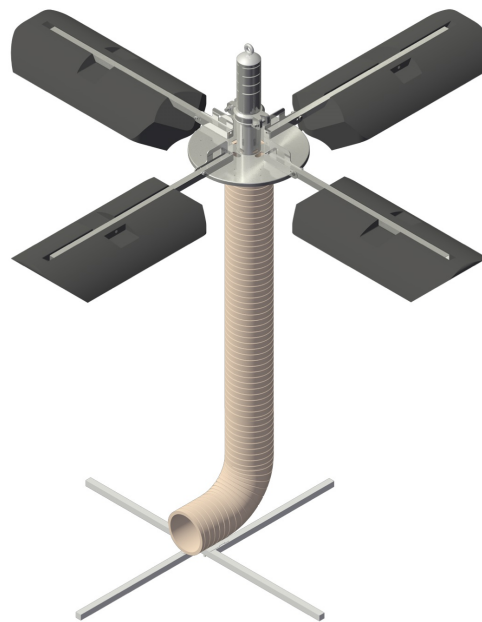

Table of Contents



GridBee SN5

Owner's Manual

Safety	1
Package Contents	4
Tools Required	6
Placement	7
Assembly	10
Electrical	18
Startup and Operation	23
Troubleshooting	24
Technical Specifications	25
Exploded Parts Diagram	26
Dimension Drawing	27
Placement Record	28
Warranty	29
Service Program	30
Customer Service	31

Safety

IMPORTANT

**YOU MUST COMPLETELY
READ AND FULLY
UNDERSTAND THESE
INSTRUCTIONS BEFORE
INSTALLING, OPERATING,
OR SERVICING THIS UNIT.**

Be sure you have read all installation, operation, maintenance and safety instructions before you install, service or begin to operate this unit.

Accidents occur every year because of careless use of industrial equipment. You can avoid hazards by following these safety instructions, and applying some ordinary common sense when operating or servicing this unit.

Keep in mind that **full operator attention and alertness** are required when operating or servicing this unit.

USE COMMON SENSE!! Most accidents can be avoided by using **common sense and concentration** on the job being done.



Carefully read safety information when you see any safety symbols.



Safety

IMPORTANT

YOU MUST COMPLETELY READ AND FULLY UNDERSTAND THESE INSTRUCTIONS BEFORE INSTALLING, OPERATING, OR SERVICING THIS UNIT.

Identify all possible hazards. Determine what safeguards are needed and implement them. **Only you, the user,** understand your product and system characteristics fully. *The ultimate responsibility for safety is with you. Your safety ultimately rests in your hands.* Do your part and you will enjoy safe, trouble free operation for years to come. This instruction manual is not intended to include a comprehensive listing of all details for all procedures required for placement, operation and maintenance. If you have a question about a procedure or are uncertain about any detail, **Do Not Proceed.** Please contact Ixom Watercare Customer Service at **866-437-8076** to speak to a representative.



IMPORTANT!!!

Follow all federal and state laws in regards to safety regulations of working at heights, confined spaces, rescue, etc. as required by the U.S. Department of Labor, Occupational Safety and Health Administration. Use necessary PPE when placing and servicing this unit.



Thin Ice Hazard

WARNING: ICE SURROUNDING MACHINE MAY NOT SUPPORT WEIGHT, KEEP CLEAR OF THIN ICE.



ELECTRICAL HAZARD

WARNING: THIS EQUIPMENT CONTAINS HIGH VOLTAGE! ELECTRICAL SHOCK CAN CAUSE SERIOUS OR FATAL INJURY. ONLY QUALIFIED PERSONNEL SHOULD ATTEMPT PLACEMENT, OPERATION AND MAINTENANCE OF ELECTRICAL EQUIPMENT. REMOVE ALL SOURCES OF ELECTRICAL POWER BEFORE PERFORMING ANY SERVICE WORK TO THE MACHINE. USE PROPER LOCKOUT TAGOUT (LOTO) PROCEDURES TO ENSURE A SAFE WORK ENVIRONMENT.



Crush Hazard

WARNING: DO NOT REMOVE ANY FLOAT ASSEMBLY BOLTS OR PINS WHILE EQUIPMENT IS FLOATING IN WATER. EQUIPMENT MUST BE SECURELY SUPPORTED BEFORE PERFORMING SERVICE.



Rotating Hazard

CAUTION: KEEP BODY APPENANDAGES OR LOOSE CLOTHING AWAY FROM EQUIPMENT WHILE OPERATING. ENSURE EQUIPMENT IS OFF BEFORE ATTEMPTING SERVICE.



Entanglement Hazard

WARNING: ENSURE THAT PERSONNEL ARE CLEAR OF THE ELECTRIC CORD AND CHAIN TO AVOID ENTANGLEMENT.



Laceration Hazard

CAUTION: EDGES MAY BE SHARP AND CAUSE LACERATION IF PROPER CARE IS NOT USED.

Safety

Protect Yourself

It is important that you comply with all relative OSHA and local regulations while installing and performing any maintenance to the mixer circulation equipment.

Key OSHA Compliance Standards that must be followed (and not limited to) are:

- **1910.146 Permit-required confined spaces**
- **1910.147 Lockout/Tagout**
- **1926.500 Fall Protection**

Fall Protection Tips

- Identify all potential tripping and fall hazards before work starts.
- Look for fall hazards such as unprotected floor openings/edges, shafts, open hatches, stairwells, and roof openings/edges.
- Inspect fall protection and rescue equipment for defects before use.
- Select, wear, and use fall protection and rescue equipment appropriate for the task.
- Secure and stabilize all ladders before climbing.
- Never stand on the top rung/step of a ladder.
- Use handrails when you go up or down stairs.
- Practice good housekeeping. Keep cords, welding leads and air hoses out of walkways or adjacent work areas.

Refer to 29 CFR 1926.500 for complete regulations set by OSHA. Refer to your state's regulations if your state established and operates their own safety and health programs approved by OSHA.

Lockout Tagout

When the On/Off switch is in the "ON" position, the mixer may start up at any time if not already operating. The mixer's On/Off switch can be locked out by placing a pad lock thru the door latch of the controller after the switch has been turned to the "OFF" position. The On/Off switch is to be used as the emergency stop.



Permit-Required Confined Spaces

A confined space has limited openings for entry or exit, is large enough for entering and working, and is not designed for continuous worker occupancy. Confined spaces include underground reservoirs, ground storage tanks, elevated tanks, silos, manholes, and pipelines.

Confined Space Tips

- Do not enter permit-required confined spaces without being trained and without having a permit to enter.
- Review, understand and follow employer's procedures before entering permit-required confined spaces and know how and when to exit.
- Before entry, identify any physical hazards.
- Before and during entry, test and monitor for oxygen content, flammability, toxicity or explosive hazards as necessary.
- Use fall protection, rescue, air monitoring, ventilation, lighting and communication equipment according to entry procedures.
- Maintain contact at all times with a trained attendant either visually, via phone, or by two-way radio. This monitoring system enables the attendant and entry supervisor to order you to evacuate and to alert appropriately trained rescue personnel to rescue entrants when needed.

Refer to 29 CFR 1910.146 for complete regulations set by OSHA. Refer to your state's regulations if your state established and operates their own safety and health programs approved by OSHA.

Package Contents



SN Series Contents

SN Small Frame Series

Qty	Unit	Part Number	Callout Number	Description	Photo
1	Each	100689	1	3DX Spray Nozzle, 280GPM@ 15psi, Complete	
1	Each	100362, 100363 & 100364	3, 4, 7, 8, 9	Core Unit, Assembled with Floats	
† 100	Ft.	10014018		Wire Rope, 3/16" x 7x19 Strand, T316SS, 100'	
† 100	Ft.	10013045		Electric Cord, 10Ga-4 X 600V, NSF Approved, 100'	
1	Each	26060640	5	† Hose, 6" x 40', NSF, White	
1	Each	26260650	6	Torque Bar, Complete Assembly	
2	Each	100547	13	Mooring Block Anchor, 40 lb, Assembled with Concrete, Chain and Shell	
2	Each	16013107	11	Hose Clamp, 5.75" to 6.625", T316SS, High Torque	
1	Each	100141		Hardware Kit, SN, Small Frame, Packaged & Ready for Install, White Tote Kit	
Contents listed below and on next page are in the Hardware Kit in the White Tote.					
1	Each	34011005		*Lexel, 5.5oz, clear squeeze tube*	
1	Each	34010106		* 1-5/16" Hole Saw *	
1	Each	100497	12	Tube, 6" OD x 4" L, 316SS, For 6" hose intake	
1	Each	14011116		Cord Grip, .625-.750, 3/4" NPT male thread, Nylon, For 4-Cond. 600V NSF cord	
1	Each	16013203	2	Groove Coupling, 6", T316SS NSF Gasket, SN10 and SN15	
8	Each	12010412		Cable Clamp, 3/16" T316SS	
1	Each	14281150		Splice Kit, Large Epoxy, 4 Connectors	
1	Each	12285160		PW Intake Pad Hardware Kit, Bagged with M8 Bolts and White Feet	









† Amount varies on specific tank requirements.

* May or may not be in hardware kit depending on installation.

Package Contents

SN Series Contents

SN Small Frame Series

Qty	Unit	Part Number	Bin Location	Description	Photo
1	Each	101312		Bus Drop Cable, .70 - .85in, SS	
1	Each	100026		Universal Penetration Kit, 1" x 6.5", T316SS Brass HDPE	
4	Each	12010104		Bolt, M8 x 45mm, T316SS	
4	Each	12010023		Nut, M8, T316SS, Nylock	
2	Each	12010409		Eye Bolt, M8 x 1.25 x 3.25", T316SS	
6	Each	12010024		Nut, M8 x 1.25, T316SS, Standard	
12	Each	12010213		Washer, M8, T316SS, Fender	
10	Each	12010710		Quick Link, 3/16", T316SS	
1	Each	101547		Chain, 5/32" x 10 Ft, T316SS, Retrieval, Cut for Dual Tether	

Tools Required

SN Series - Small Frame

Tools Required

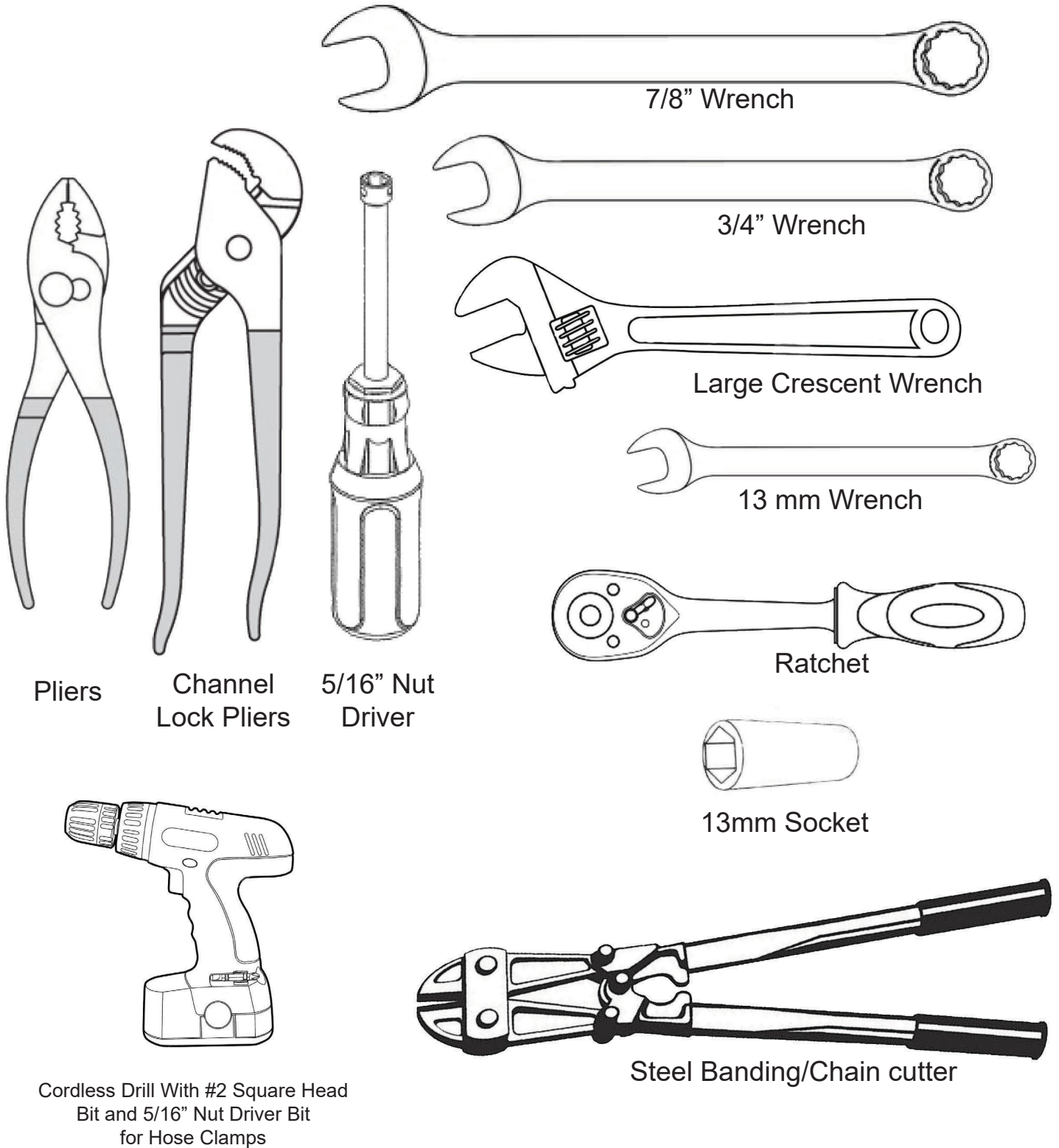

Placement Site Preparation

SN Small Frame Placement

SN Small Frame Series

Properly planning out the job site before proceeding is very important to performing an efficient and successful potable water equipment placement. Every potable water tank and reservoir is unique; therefore, the following are general guidelines and considerations that will need to be evaluated for each specific site.

Hatch Requirements

Hatch size must require a minimum clear opening of at least 18 inch x 18 inch square (46cm x 46cm) to allow the SN Small Frame collapsible unit assembly to be placed. To place the unit in the collapsible setting, the hatch needs to be 24 inch x 24 inch (61 cm x 61cm).

Wet Or Dry Placement

A decision will be required to either place the machine while the reservoir is empty or filled with water.

Wet placements are generally preferred when the units are placed by our factory placers to allow for proper final adjustments and settings during startup which directly follows placement. Our factory placement teams have extensive training and many placement tools to assist in a wet placement.

If proper equipment and safety training are not available, a wet placement should not be attempted, and therefore a dry placement will be required and startup will have to follow at a later time once the reservoir is filled with water.

Sanitary Requirements

For potable water equipment placements, it is very important to maintain sanitary conditions by properly disinfecting all equipment and personnel that come into contact with the reservoir interior and potable water. It is recommended that once the hatch is chosen for equipment and personnel entry, a clean zone be designated around the hatch. The clean zone establishes a boundary where anything that comes in contact with that zone shall be sanitary and adequately disinfected, allowing it to pass through the clean zone and into the reservoir. Standard practice in the United States is to use a 200 part per million sodium hypochlorite in water solution as a disinfectant to all equipment and personnel clothing/footwear coming into contact with the reservoir interior and potable water.

Safety

Prior to commencing placement and finalizing the placement work areas, the jobsite should be evaluated for all safety hazards including, but not limited to: Confined Space Entry, Fall Protection, Working Over Water, Overhead Equipment, Communication Barriers, Equipment Handling, etc.

Once safety hazards are identified, hazard mitigation measures should be taken and safety training procedures must be practiced to accomplish the placement without incident.

Placement

Placement Overview

SN Small Frame Series

Details listed on this page include items provided by Others, not Ixom. Please refer to your projects Scope of Work for more details. Ixom does not provide any electric work.

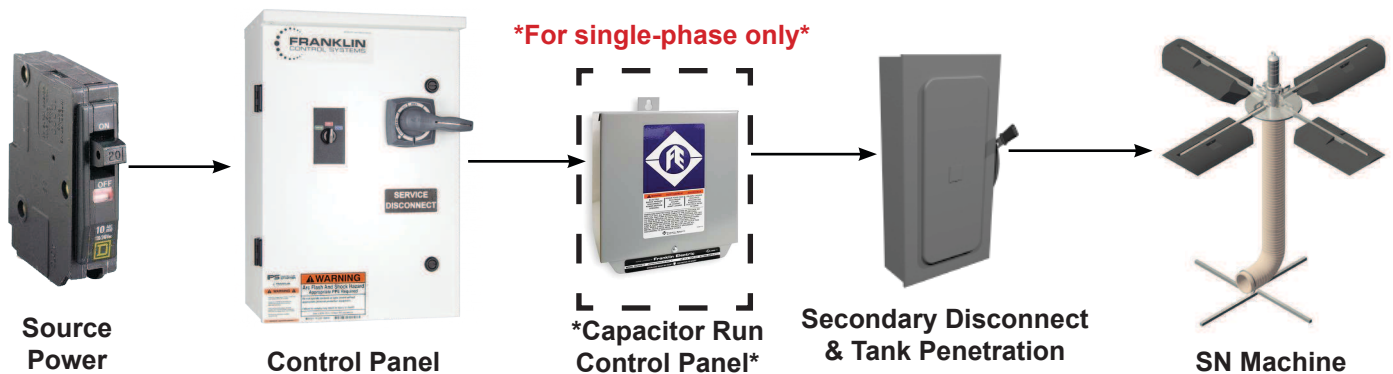
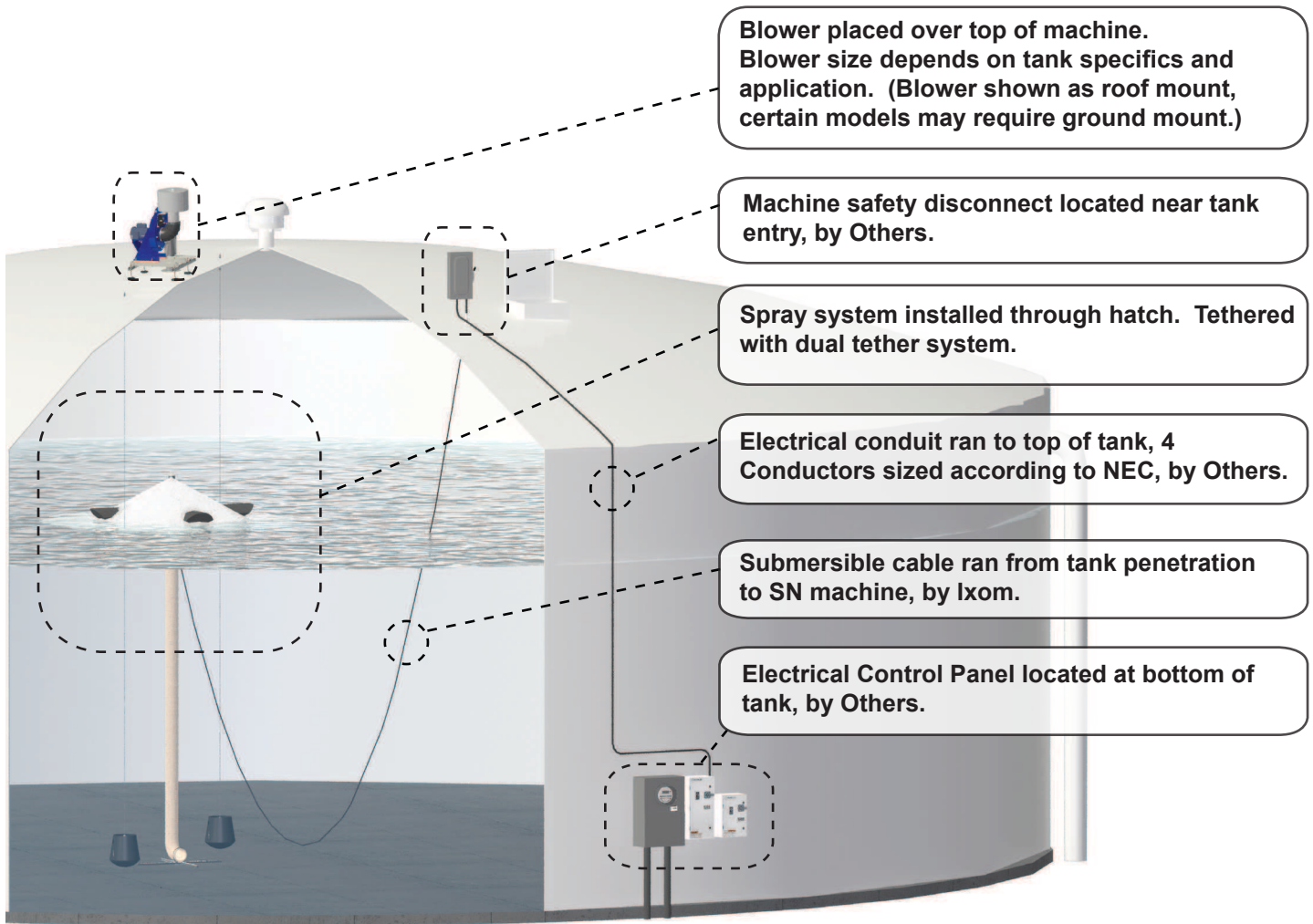

Visual Dual Tethering

SN Small Frame Series

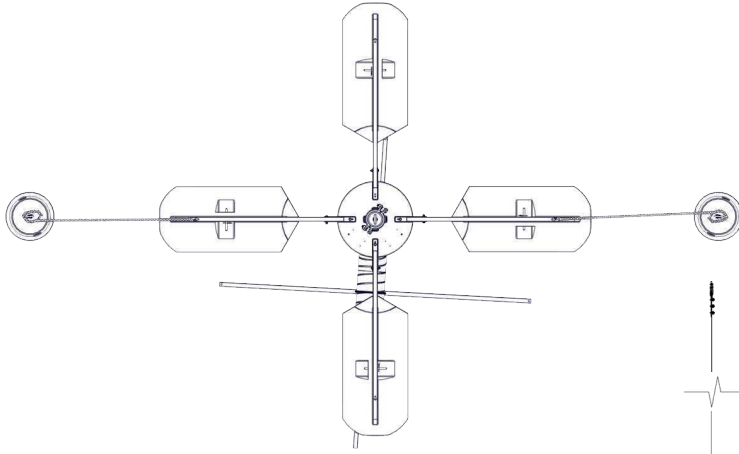

TOP VIEW SN DUAL TETHERING

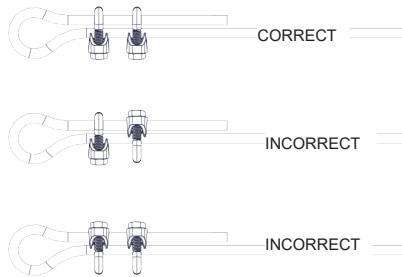

CABLE CLAMP DETAIL

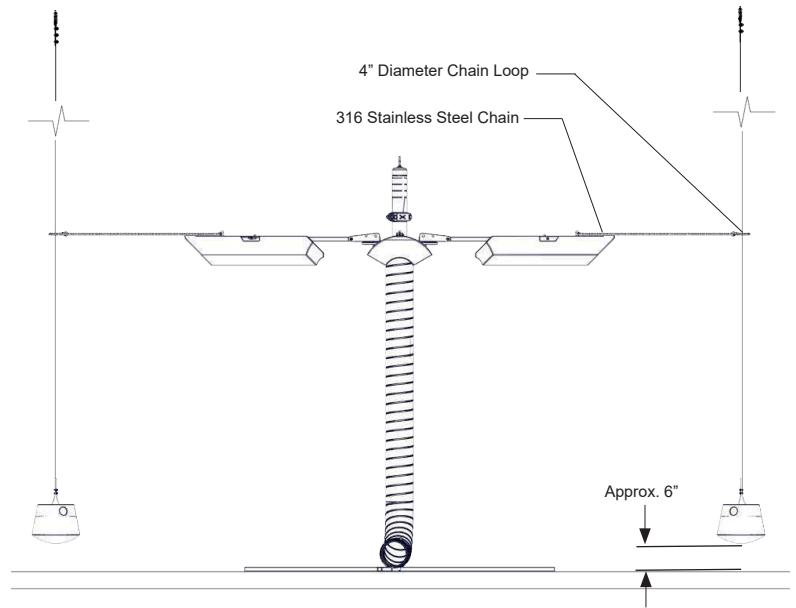

FRONT VIEW SN DUAL TETHERING

CONCRETE ROOF
* Anchor provided by Contractor / Tank Manufacturer

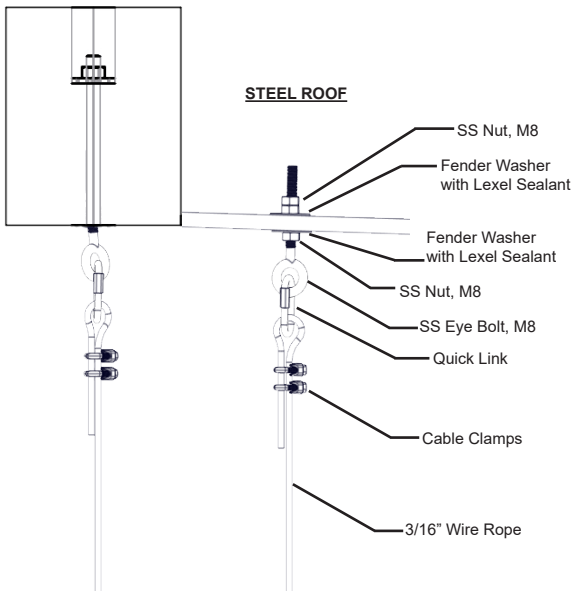

ROOF CONNECTION DETAIL

CABLE CLAMPS MUST BE BELOW ANCHOR SHELL



MOORING BLOCK CONNECTION DETAIL

SN Series - Small Frame Assembly

IMPORTANT! The following pages give detailed instructions on how to assemble different portions of the machine; however, the order in which the components are assembled and entered into the reservoir may need to be altered based on the hatch size and whether the reservoir will be full or empty. For instance, the hose assembly to the base of the Frame Plate can be performed on the reservoir exterior prior to lowering the equipment inside if the hatch has a clear opening of **at least 24 inch diameter (60cm)**. A hatch this size or larger will allow the SN collapsible unit assembly to be installed without Float disassembly required. For smaller hatches, the SN collapsible unit assembly will need to be broken down into multiple components and the hose assembly will need to be performed inside the reservoir. The following order of operations listed is based on a wet installation and small hatch opening.

Float Disassembly - Only if Required (See Figures 1 & 2)

TOOLS REQUIRED

13mm Wrench and Socket Wrench

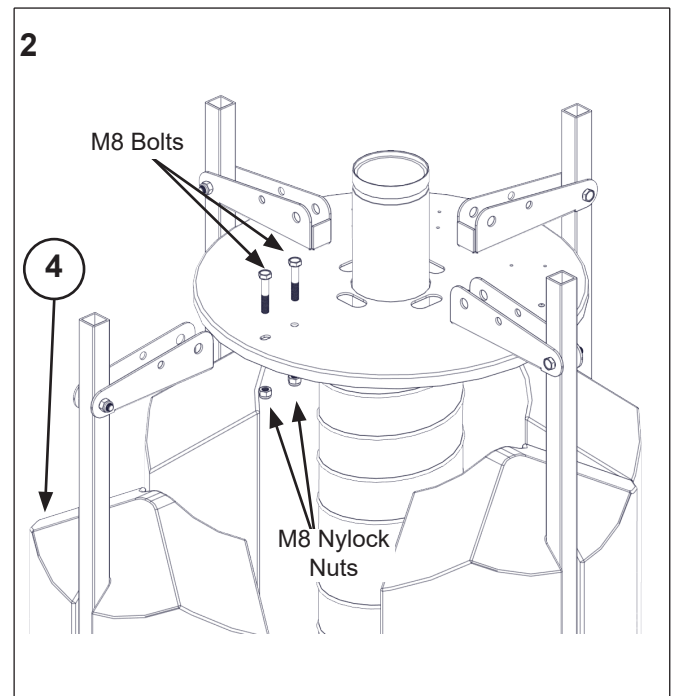
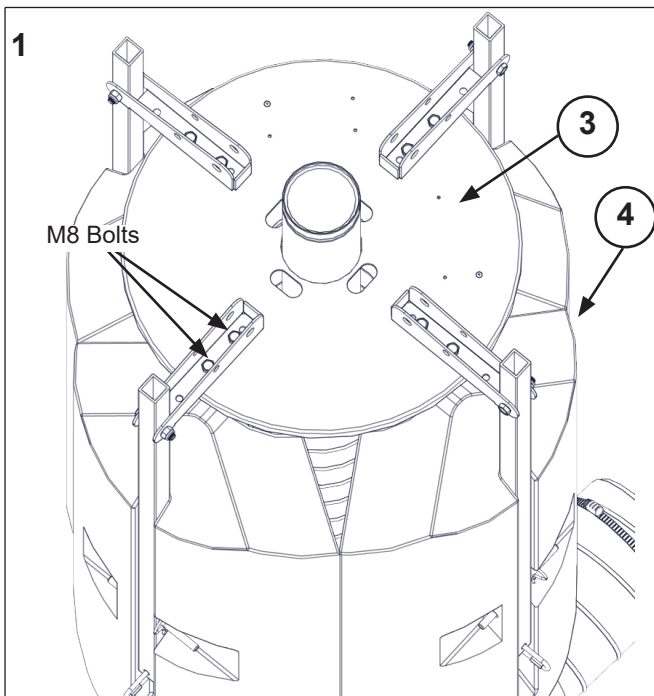

STEP 1: Locate and remove two M8 Bolts and M8 Nylock Nuts at the bottom of the Float Arm Channel to separate the first Float Arm from the Floating platform as shown. (See Figure 1 & 2)

STEP 2: Place the loose bolts back into either the Float Arm Channel or Floating Platform and hand tighten so they are ready for assembly once the equipment is passed through the hatch. (See Figure 2)

STEP 3: Repeat STEPS 1 and 2 for the other three Floats.

SN Series - Small Frame Assembly

Pump/Motor/Nozzle Assembly (See Figures 3 & 4)

TOOLS REQUIRED:

3/4" Wrench • 7/8" Socket Wrench • Large Crescent Wrench • Food-Grade Silicone Lubricant

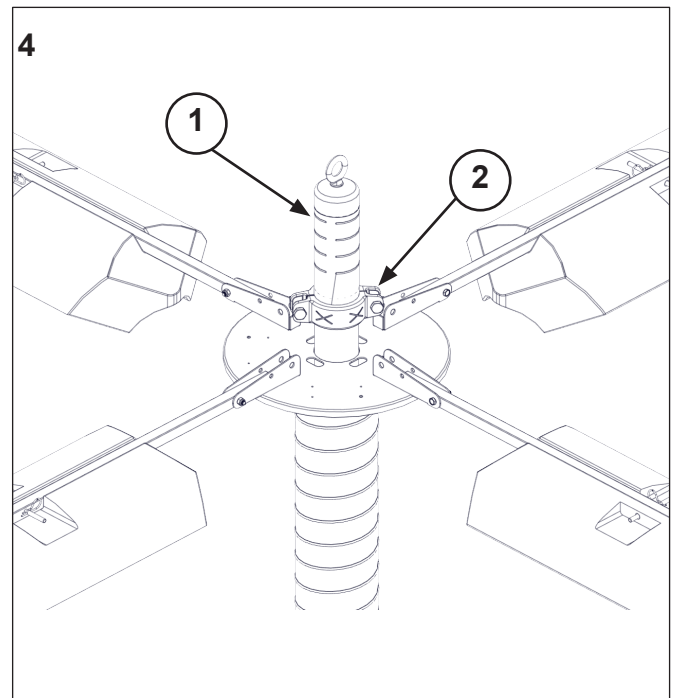
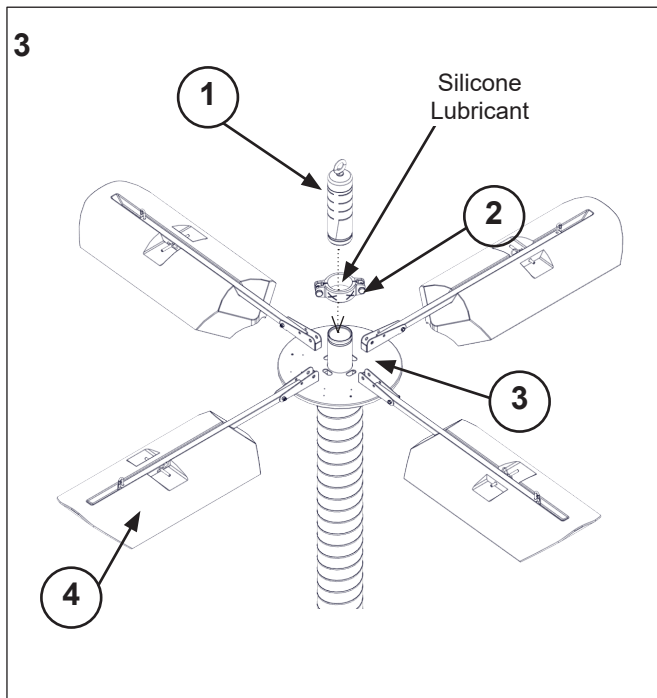

STEP 1: Locate the nozzle assembly, 3" groove coupling with gasket, and pump/motor assembly.

STEP 2: Securely support the pump/motor assembly so the pump discharge is at least 12" from the work surface. It may be helpful to have an extra hand in the following steps.

STEP 3: Apply the silicone lubricant on the groove coupling gasket. Slide the coupling/gasket on the end of either the nozzle or the pump discharge pipe. **(See Figure 3)**

STEP 4: Place the nozzle on the pump discharge pipe and slide the gasket centered of the seam. Place the groove coupling over the gasket and ensuring the clamp is seated into the grooves of the nozzle and pump discharge pipe. **(See Figure 4)**

STEP 5: Tighten the nozzle clamp, alternating bolts a couple times during the process to ensure an even clamping force around the pipe.

Alternative Option: The nozzle can also be attached to the pump/motor assembly after the SN unit is installed and floating in the tank.

SN Series - Small Frame Assembly

Hose to Frame Plate Assembly (See Figures 5, 6 & 7)

TOOLS REQUIRED

5/16" Nut Driver for Hose Clamps

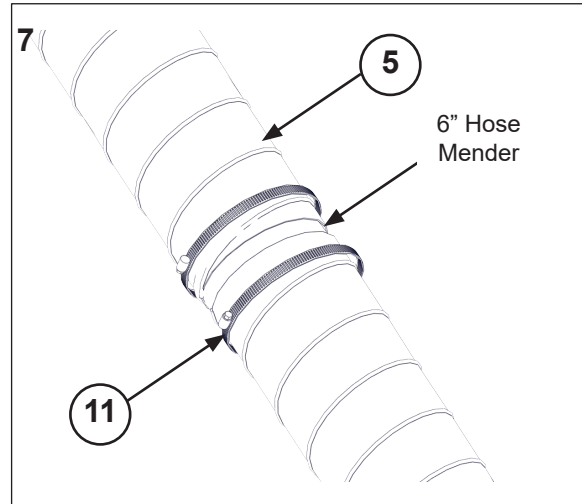
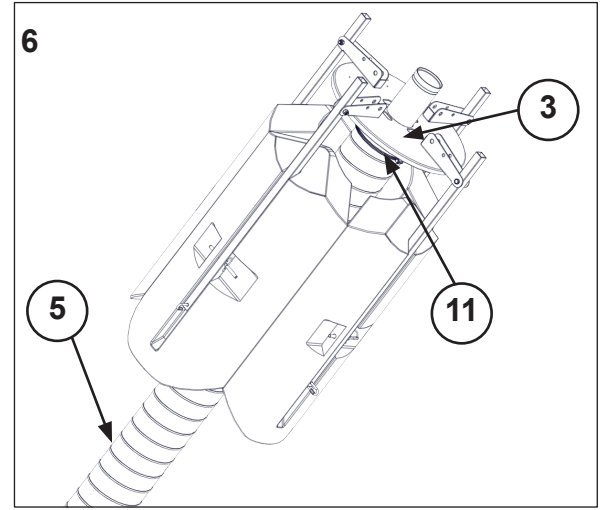
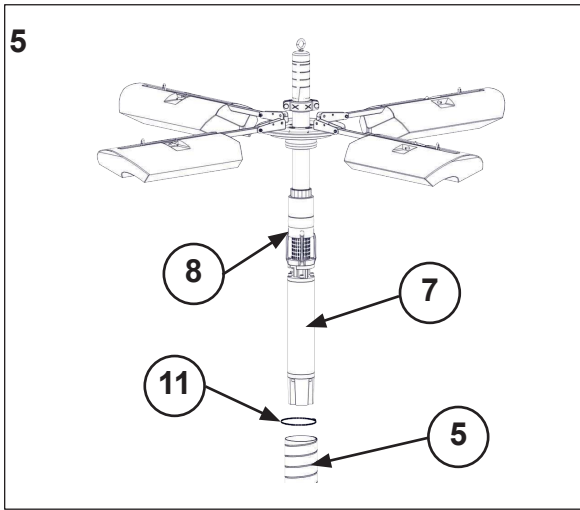

STEP 1: Locate one end of the hose section and place hose clamp over the end. Be sure that hose and clamp are installed above the metal rib of the flange and then tighten hose clamp as tight as possible to firmly secure hose.

STEP 2: Fasten Hose to bottom of Frame Plate by pushing Hose up and all the way up above metal rib. (See Figure 5)

STEP 3: Be sure that hose and clamp are installed above metal rib and then tighten hose clamp as tight as possible to firmly secure hose to the bottom of the Frame Plate. (See Figure 6)

STEP 4: For multiple hose sections, connect two sections together using a hose mender and hose clamps as shown. (See Figure 7)

SN Series - Small Frame Assembly

Hose to Torque Bar Assembly (See Figures 8, 9 & 10)

TOOLS REQUIRED

5/16" Nut Driver for Hose Clamps

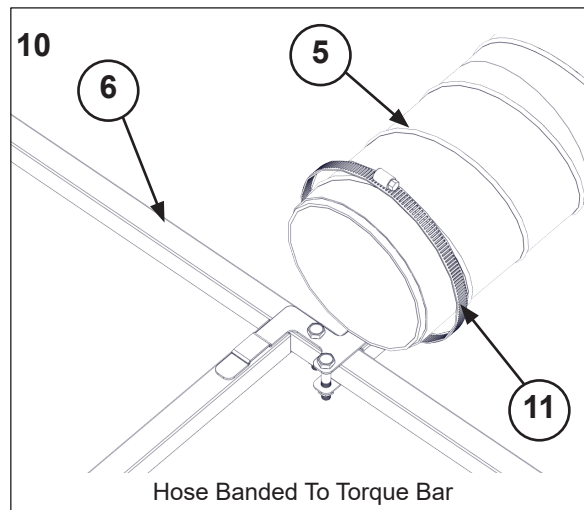
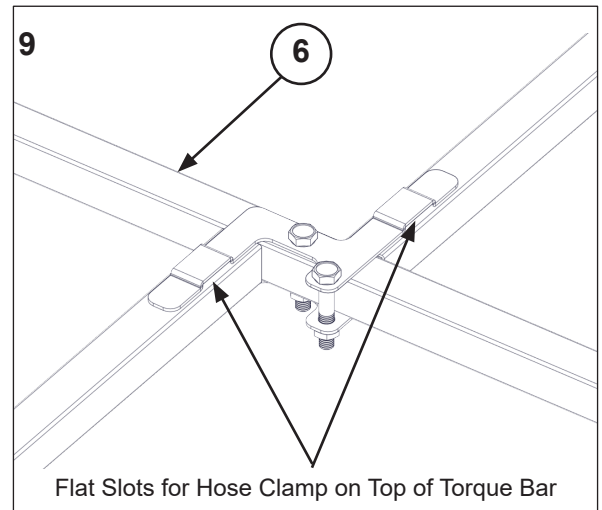
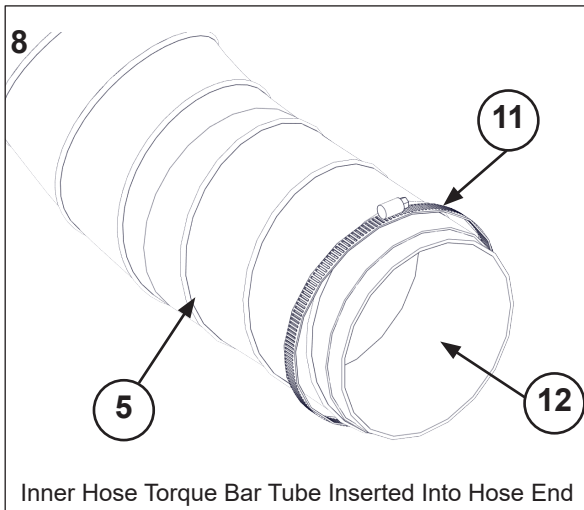

STEP 1: Locate end of the Hose Section opposite of the Frame Plate and insert the 6" Tube for 6" Hose Intake inside the end of the hose until approximately flush as shown. (See Figure 8)

STEP 2: Insert a 6" Hose Clamp and insert the end through one of the two small flat slots with Hose Clamp on top of the Torque Bar as shown. Either slot will work fine. (See Figure 9)

STEP 3: Position the end of the hose so that the clamp is centered over the 6" Hose Intake Tube. Secure the torque bar to the hose by tightening the hose clamp using a 5/16" nut driver. (See Figure 10)

STEP 5: Leave the Torque Bar in the folded position ready for entry through the hatch.

SN Series - Small Frame Assembly

Equipment Entry Through Hatch (See Figures 11 & 12)

Depending on the hatch size configuration and type of reservoir, more equipment assembly may be possible outside the reservoir prior to passing the equipment through the hatch. The following order for lowering equipment down is recommended for a wet installation once an entrant has safely entered the tank and is ready for interior assembly.

TOOLS REQUIRED

Pliers • 13mm Wrench • 13mm Socket Wrench • Large Crescent Wrench • 3/4" Socket Wrench
Equipment Hoisting Tools / Rescue Equipment

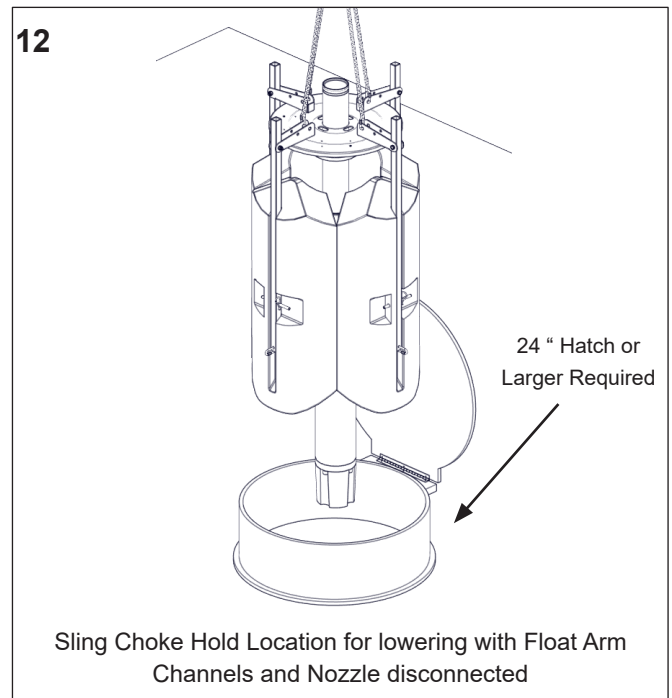
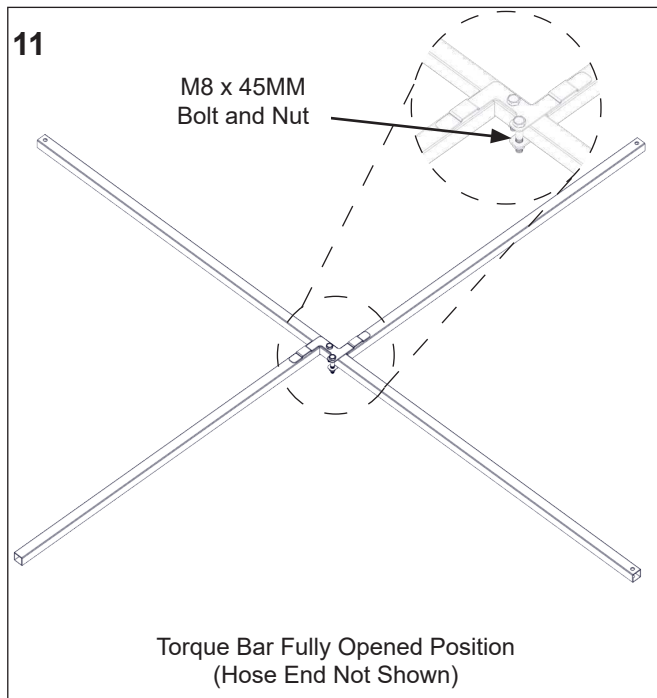

STEP 1: Lower the folded Torque Bar Assembly and Hose through the hatch to the entrant. The entrant then needs to expand Torque Bar into the fully opened position, and install an M8 x 45mm bolt and nylock nut through the torque bar tab to secure the torque bar in the open position. **(See Figure 11)**

STEP 2: With the Frame Plate Assembly positioned and tied up near the hatch, slowly lower the Torque Bar and Hose down to the reservoir floor or until the hose is hanging from the Frame Plate Assembly. The Hose may take some time to vent out trapped air which is ok and may allow the following steps to take place prior to it sinking.

IMPORTANT: The next Step will require equipment to hold the unit in position and lower it down in a slow, controlled manner.

STEP 3: Using a choke hold with a sling or chain just below the Nozzle Clamp, or lifting connection attached to lifting eye of the Nozzle lower the Frame Plate Assembly down until the Frame Plate is approximately several inches above the water line. While lowering, carefully allow the submersible cable to unspool and follow the Frame Plate down.

SN Series - Small Frame Assembly

Equipment Entry Through Hatch - Continued (See Figures 13 & 14)

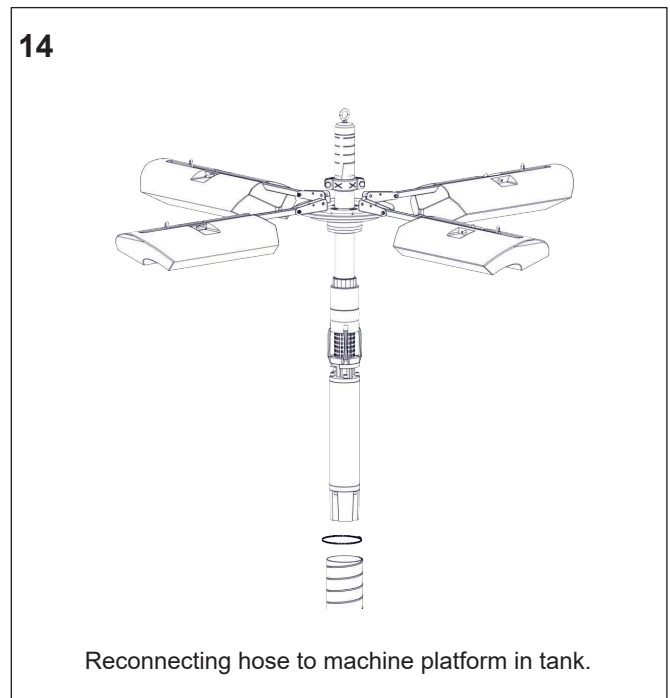
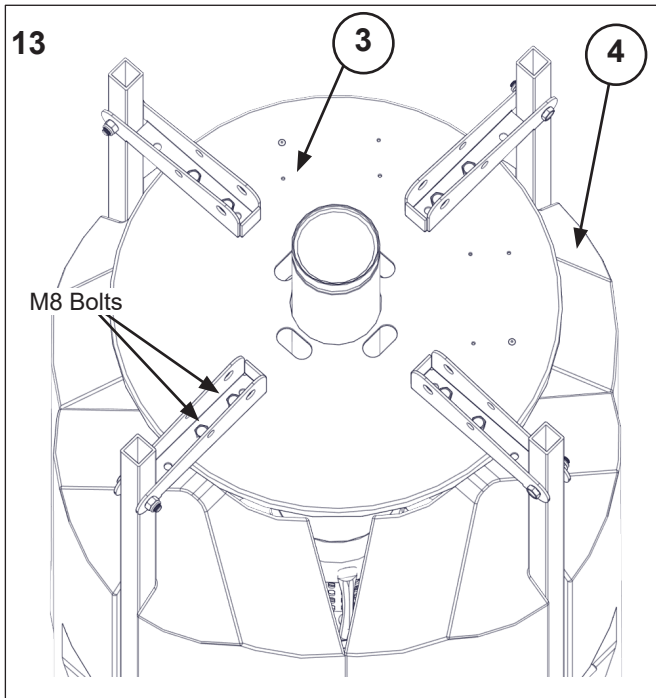

STEP 4: If disassembled from previous steps, with Frame Plate Assembly suspended several inches above the water, use two M8 bolts to fasten each float arm channel to the Frame Plate Assembly. (See Figure 13)

STEP 5: Lower the complete assembled unit into the water until it floats on its own.

STEP 6: Locate the end of the intake hose chain and attach at the top frame. (See Figure 14)

STEP 7: With the SN Unit floating inside the tank, the unit can now be positioned in the desired location inside the tank.

NOTE: It is recommended the SN Unit be restrained using a dual vertical tether system as described on the next two pages.

Assembly

SN Series - Small Frame Assembly

Tethering Assembly

Vertical Anchor Line Installation (See Figures 15-19)

During operation, the SN Unit will have a tendency to move given the forces of the spray leaving the nozzle. If the unit needs to be restrained horizontally, therefore the unit will need to be loosely tethered to vertical anchor lines to hold it in place at varying water levels.

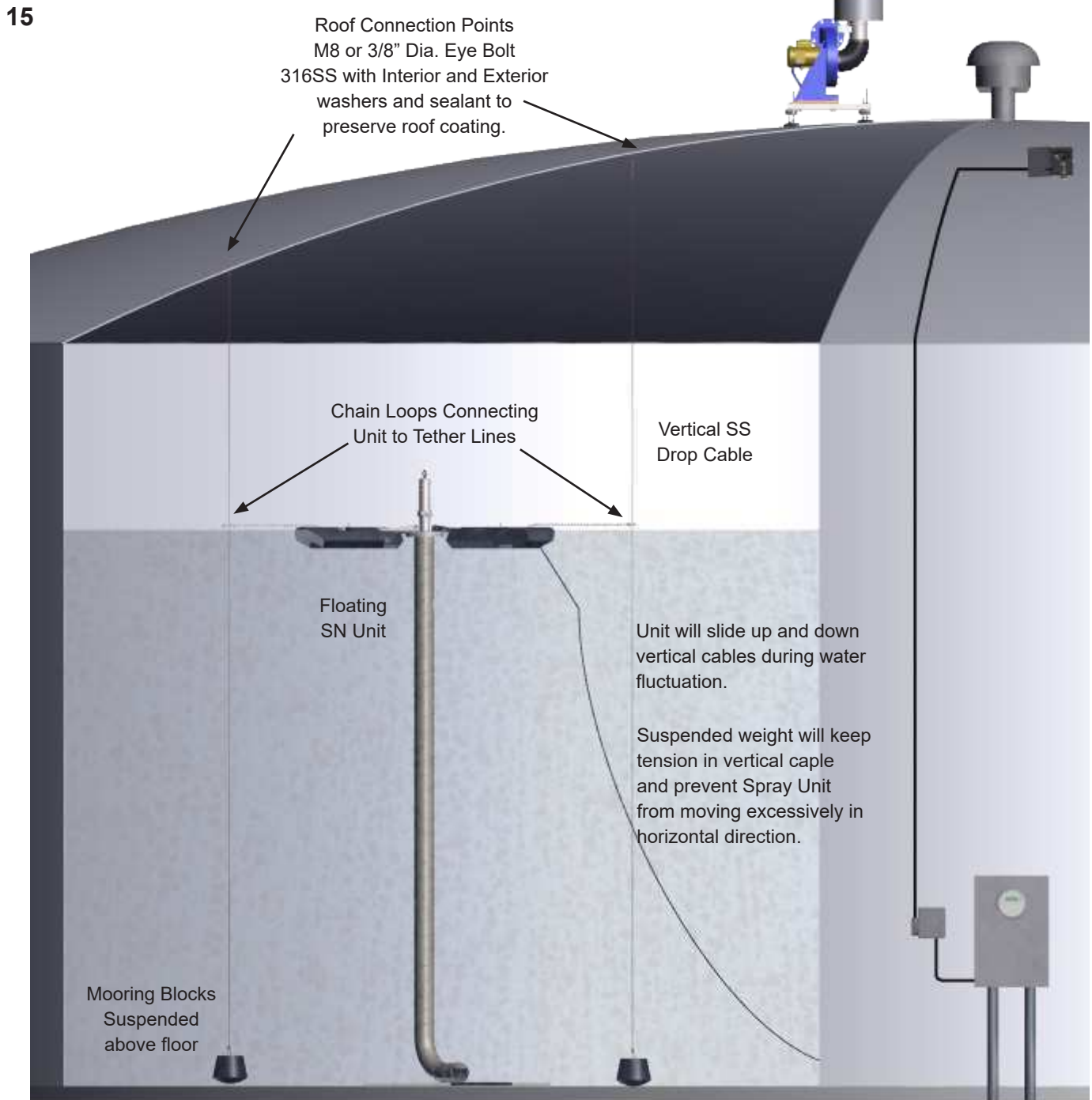

Assembly

SN Series - Small Frame Assembly

Tethering Assembly

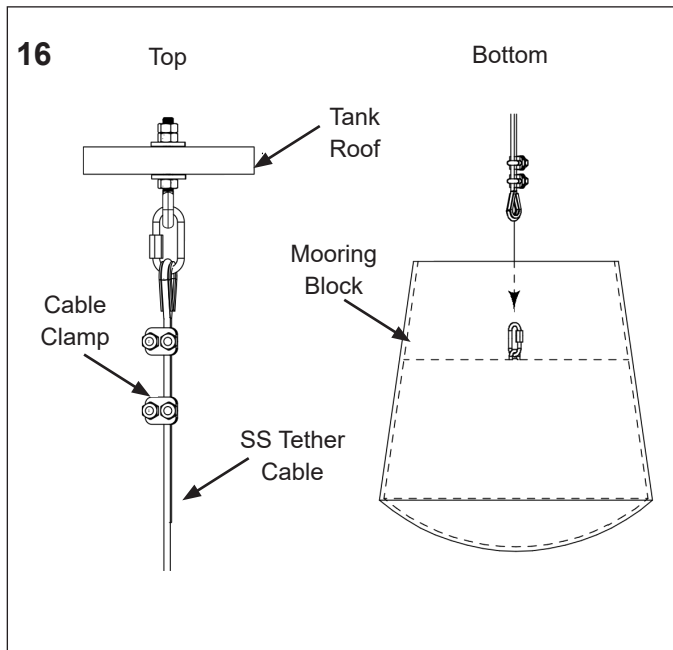

Vertical Tether Connections

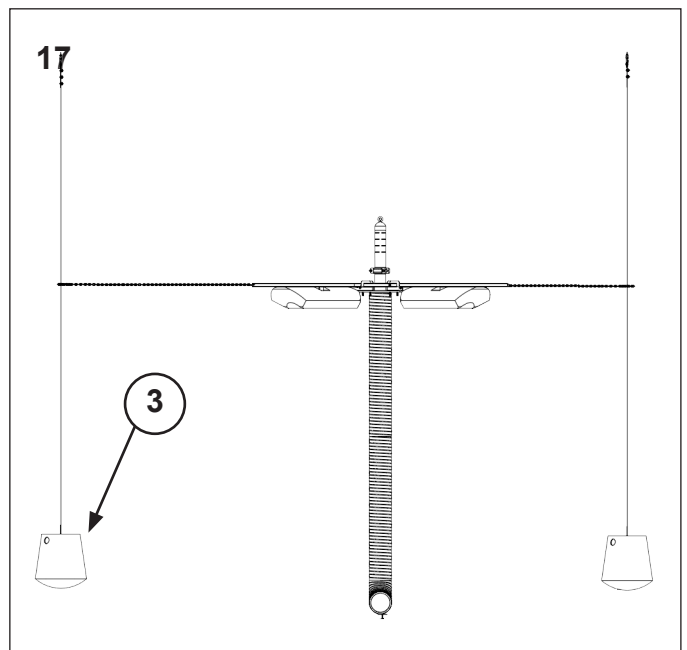

Tether Connection Side View

SN Units Electrical Wiring

Power Connection - Motor and control wiring, overload protection, disconnects, accessories and grounding should conform to the National Electrical Code and local codes and practices.

During factory placement, the submersible power cable from the submersible motor will be terminated at the roof of the reservoir. This will be the point of hand off for the electrician to bring power to.

Electric Cable Routing

Depending on the roof construction, various methods of providing a sealed electric cable penetration will be required. The following steps offer an example of a sealed fixture penetration available for steel and aluminum roofs.

- STEP 1:** Find a suitable location near the hatch and mark a penetration point on the roof for the through tank fitting that the electric cable will pass through. When selecting a penetration location through the roof, be sure to confirm the following:
- A.** The penetration is not going to interfere with internal obstructions, (i.e. roof beams, cathodic systems, etc.)
 - B.** The penetration is centered within a clear footprint of approximately 8-inch X 8-inch (20cmX20cm)
 - C.** The penetration can be accessed on the inside of the tank when reaching from the hatch.
- STEP 2:** Use a cordless drill with the 1-5/16 inch (33mm) hole saw provided and begin drilling a hole through the tank roof. A small amount of food grade vegetable oil works well for lubrication of the hole saw. Prior to completing the penetration, position a container or catch net below the penetration point to catch filings and the hole cut out.
- STEP 3:** Remove all filings and thoroughly clean all surfaces around the penetration before removing the catch net. The penetration is now ready for a sealant application and placement of the Through Tank Fitting.
- STEP 4:** Apply a healthy amount of LEXEL brand sealant provided on all the surrounding surfaces of the penetration (interior, exterior, and inner wall). This will prevent future corrosion of the roof around the fixture.

T316 SS CORD BOLT: TANK PENETRATION ASSEMBLY

TANK PENETRATION IS SEALED WITH HDPE WASHERS ACCOMPANIED BY LEXEL® CO-POLYMER RUBBER-BASED SEALANT

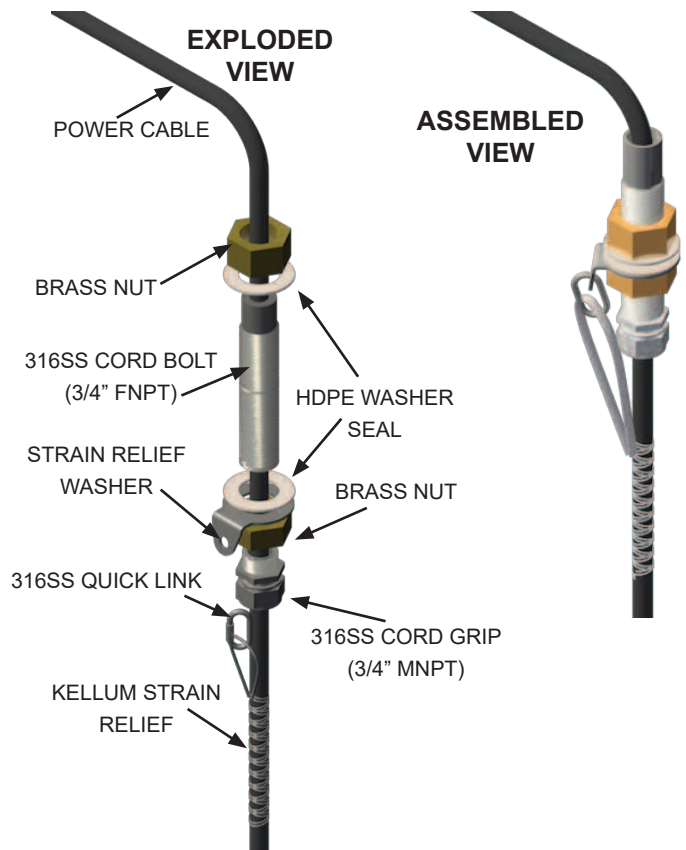
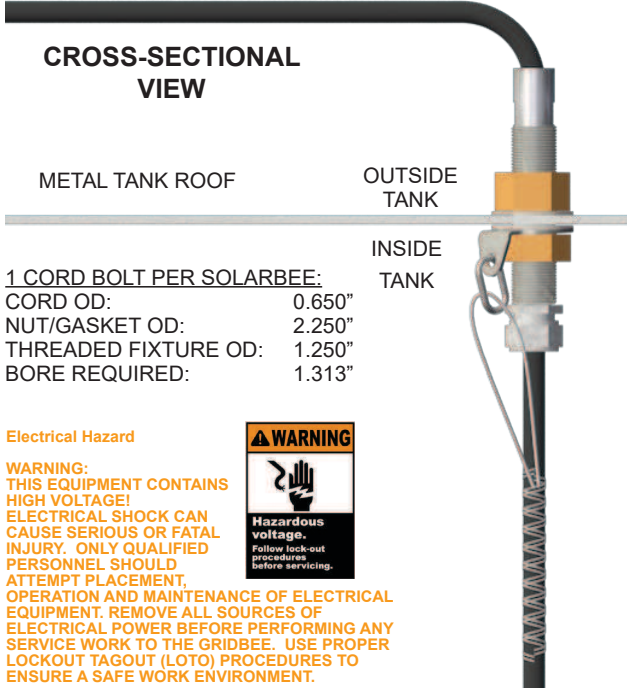

Electrical

SN Units Electrical Wiring

Electrical Connection

Below is the epoxy splice for making a water-tight sealed electrical connection. The electrical splices may have already been done. If so, the below steps can be skipped.

TOOLS REQUIRED:

Electrical Splice Crimp/Stripping Tool
Caulking Gun

STEP 1: Cut back outer jacket about 2 inches, Caution do not nick jacket of the inner wire. Off set/stagger the inner wires, and strip ends. *(See Figure 1)*

STEP 2: Place metal crimp around the wires, crimp and place protective cover over crimp. *(See Figure 2)*

STEP 3: Take pvc sleeve and fill half way with epoxy. Push wires all the way to the bottom to ensure crimps are covered with epoxy. *(See Figure 3)*

STEP 4: Fill remaining gap with epoxy and plunge wires to remove air from the epoxy. *(See Figure 4)*

Note: Epoxy has roughly 1-hr set time at 60 degrees. During this time, try to ensure the splice is upright so no epoxy can spill out.

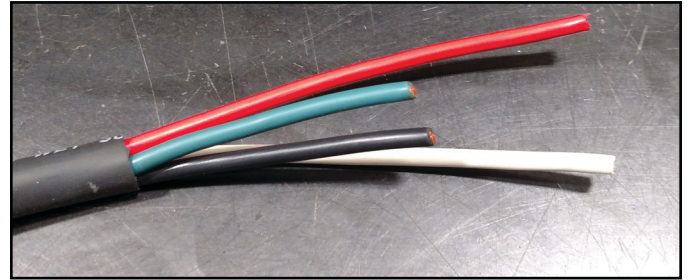

Figure 1

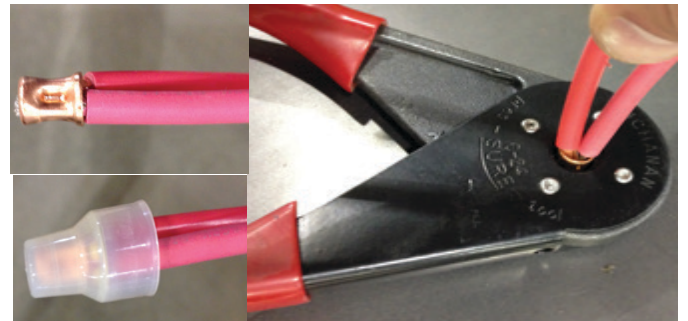

Figure 2

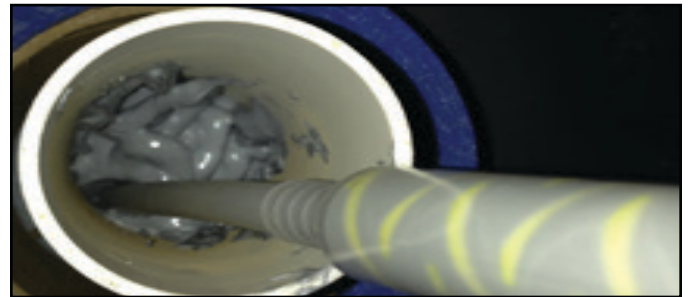

Figure 3



Figure 4



Epoxy Electrical Splice Kit

Single Phase Wiring for THM SN Spray Units

SN Small Frame Series

Single-Phase Motor Specifications (60 Hz) 3450 rpm:

TYPE	RATING					FULL LOAD		MAXIMUM LOAD		WINDING (1) RES. IN OHMS		EFFICIENCY		POWER FACTOR %		LOCKED ROTOR AMPS	KVA CODE
	HP	KW	VOLTS	HZ	S.F.	(2) AMPS	WATTS	(2) AMPS	WATTS	M=MAIN RES. S=START RES.	S.F.	F.L.	S.F.	F.L.			
4" 3-Wire	5	3.7	230	60	1.15	Y23.0 B15.9 R11.0	4830	Y27.5 B19.1 R10.8	5500	M0.71-0.82 S1.8-2.2	78	77	100	100	129	G	

- (1) Main winding - yellow to black
Start winding - yellow to red
- (2) Y = Yellow lead - line amps
B = Black lead - main winding amps
R = Red lead - start or auxiliary winding amps
- 5 hp Control Boxes date coded 01M and older have **60 MFD** run capacitors. Current values should be:
 Y23.0 @ FL Y27.5 @ Max. Load.
 B19.1 B23.2
 R8.0 R7.8

Single-Phase Motor Fuse Sizing:

TYPE	RATING			CIRCUIT BREAKERS OR FUSE AMPS			CIRCUIT BREAKERS OR FUSE AMPS		
				(MAXIMUM PER NEC)			(TYPICAL SUBMERSIBLE)		
	HP	KW	VOLTS	STANDARD FUSE	DUAL ELEMENT TIME DELAY FUSE	CIRCUIT BREAKER	STANDARD FUSE	DUAL ELEMENT TIME DELAY FUSE	CIRCUIT BREAKER
4" 3-Wire	5	3.7	230	80	45	60	70	30	60



Capacitor Run Control Panel and Wiring Schematic

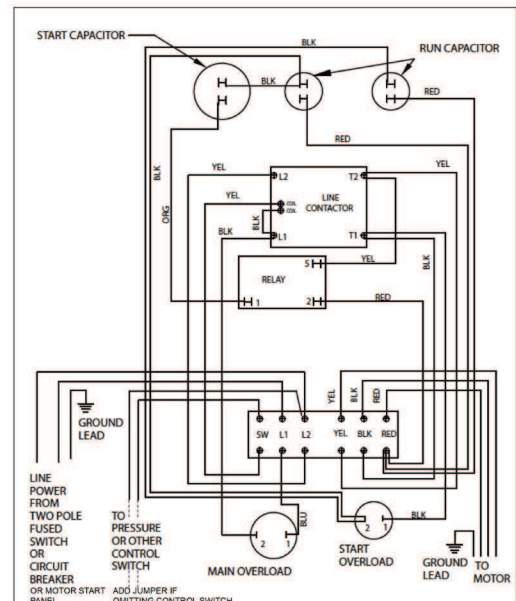

Three Phase Wiring for THM SN Spray Units

Three Phase Motor Specifications (60 Hz) 3450 RPM:

TYPE	RATING					FULL LOAD		MAXIMUM LOAD		LINE TO LINE RESISTANCE OHMS	EFFICIENCY		LOCKED ROTOR AMPS	KVA CODE
	HP	KW	VOLTS	HZ	S.F.	AMPS	WATTS	AMPS	WATTS		S.F.	F.L.		
4" STD	5	3.7	200	60	1.15	18.3	4800	20.5	5500	.68-.83	78	78	116	K
			230	60	1.15	15.9	4800	17.8	5500	.91-1.1	78	78	102	K
			460	60	1.15	7.5	4800	8.6	5500	3.6-4.4	78	78	53.7	K
6" STD	10	7.5	230	60	1.15	28.4	9400	32.2	10800	.47-.57	79	79	172	H
			380	60	1.15	17.6	9400	19.6	10800	1.2-1.5	79	79	104	H
			460	60	1.15	14.2	9400	16.1	10800	1.9-2.4	79	79	86	H
6" STD	15	11	380	60	1.15	25.8	13700	28.9	15800	.77-.95	81	81	161	H
			460	60	1.15	20.8	13700	23.7	15800	1.1-1.4	81	81	133	H

TYPE	RATING			CIRCUIT BREAKERS OR FUSE AMPS			CIRCUIT BREAKERS OR FUSE AMPS		
				(MAXIMUM PER NEC)			(TYPICAL SUBMERSIBLE)		
	HP	KW	VOLTS	STANDARD FUSE	DUAL ELEMENT TIME DELAY FUSE	CIRCUIT BREAKER	STANDARD FUSE	DUAL ELEMENT TIME DELAY FUSE	CIRCUIT BREAKER
4" STD & HI-TEMP	5	3.7	200	60	35	50	60	25	50
			230	50	30	40	45	20	40
			460	25	15	20	25	10	20
6" STD.	10	7.5	230	90	50	80	90	40	80
			380	60	35	45	50	25	45
			460	45	25	40	45	20	40
6" STD.	15	11	380	80	50	70	80	35	70
			460	70	40	60	60	30	60

Three Phase Submersible Motor and Pump Protection Wiring

Base Unit



- ① Voltage Inputs (L1, L2, L3)
- ② Integrated Sensor Coils
- ③ Insulation Check Connection
- ④ Test/Reset Switch
- ⑤ Fault Light (Base)
- ⑥ Bluetooth Pairing QR Code
- ⑦ Control Circuit Terminals
- ⑧ Input/Output Terminals

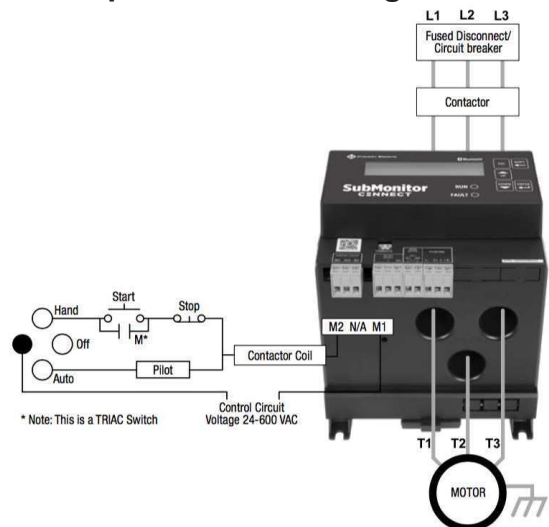

Electrical

Universal Fixture Assembly

Tank Penetration Assembly

TANK PENETRATION IS SEALED WITH HDPE WASHERS ACCOMPANIED BY LEXEL® CO-POLYMER RUBBER-BASED SEALANT

1 CORD BOLT PER GRIDBEE:

NUT/GASKET OD: 2.250"
THREADED FIXTURE OD: 1.250"
BORE REQUIRED: 1.3125"

CROSS-SECTIONAL VIEW

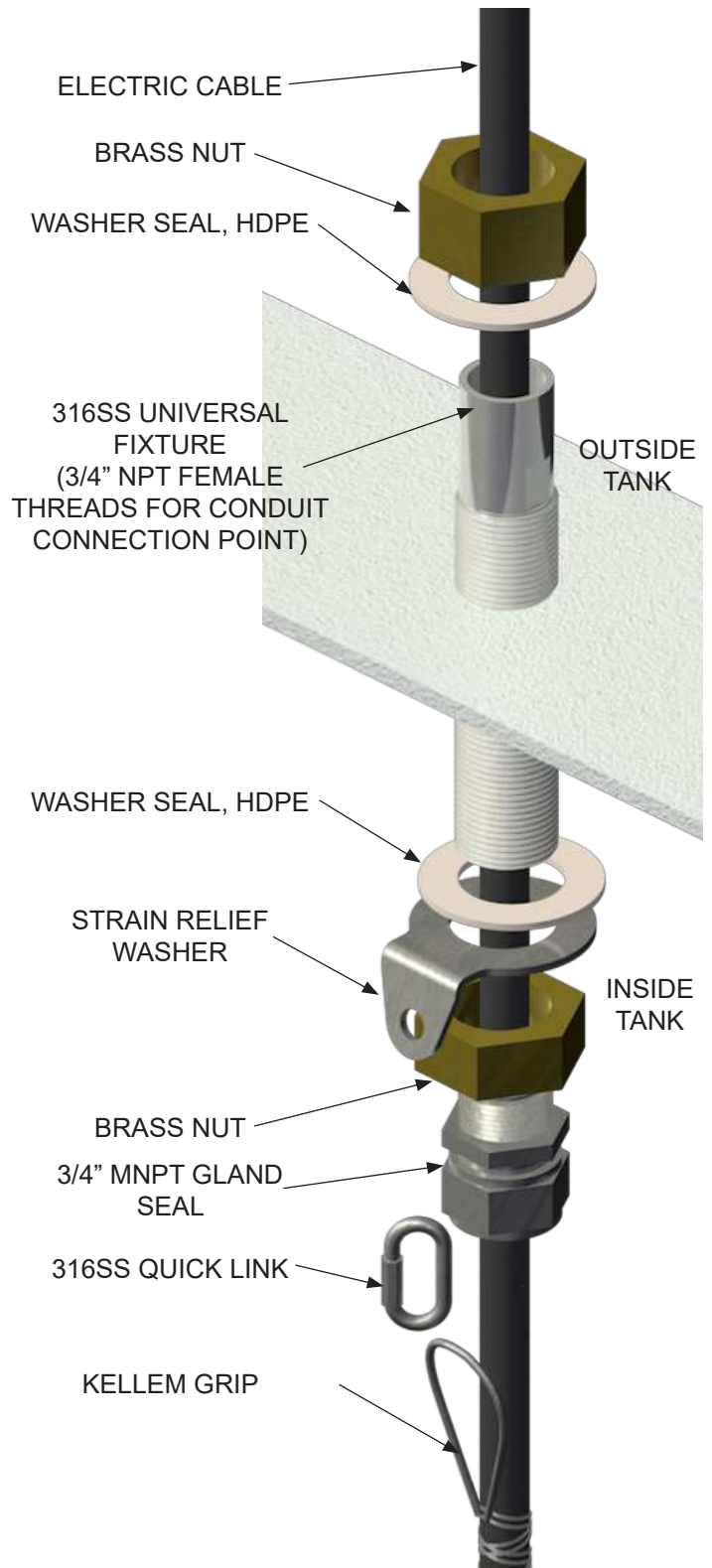
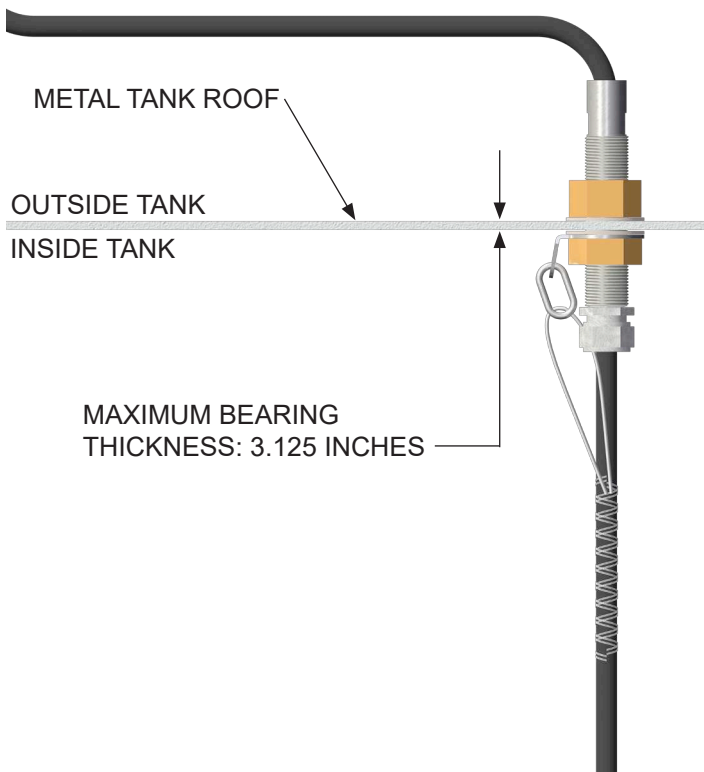

NOT DESIGNED AS A SUBMERSIBLE PENETRATION.

Startup and Operation

SN Startup and Operation

Wiring

Placement Checks

Before starting the SN Spray Unit a few checks need to be done to confirm the placement is correct.

Placement Check	Check
Is the SN Spray Unit properly tethered? (Assembly)	
Is the cord ran through the cord seal and cord seal tightened at the interior of the cord fixture? (Assembly)	
Is the top splice between submersible cable conductors and exterior electric conductors insulated from each other and individually sealed to protect from corrosion? (Assembly)	
Is the control panel wired correctly? (Control Panel Diagram)	
Is the SN Spray Unit submerged within the minimum water depth required? (Technical Specifications)	
Is the Motor rotating the correct direction? (See Rotation Check below)	

Final Checks

Now that the install checks have been completed. Now to confirm the continuity and discontinuity and then start the SN Spray Unit.

Check	Reading			
	Single Phase	Three Phase		
Continuity Check (Motor Windings + Splice + Wire) Reference Wiring for Line to Line Ohms	L1:L2	L1:L2	L2:L3	L1:L3
Discontinuity Check (Power to Ground) Should be Open to Ground	L1: GND	L1: GND	L2:GND	L3:GND
Source Voltage Reading (while unit is running)	L1:2	L1:2	L2:L3	L1:L3
Amperage Reading (while unit is running) Reference Wiring Full Load / Max Load	L1	L1	L2	L3
Flow Check Auditory				
Flow Check Visual				

Rotation Check - (Three Phase Only)

Before finalizing the placement, the motor rotation needs to be checked. With someone observing the SN Spray Unit, briefly turn the unit on for several seconds and observe the flow pattern, look for how far out the spray reaches. Turn unit off, isolate power, and have a qualified person switch 2 of the 3 motor leads of outgoing power. Repeat operation again for several seconds and observe the SN Spray Unit flow pattern again. Determine which wiring configuration produced the flow pattern that reaches out the furthest and finalize with that wiring of the outgoing power leads. See Figure 1 for proper flow direction.

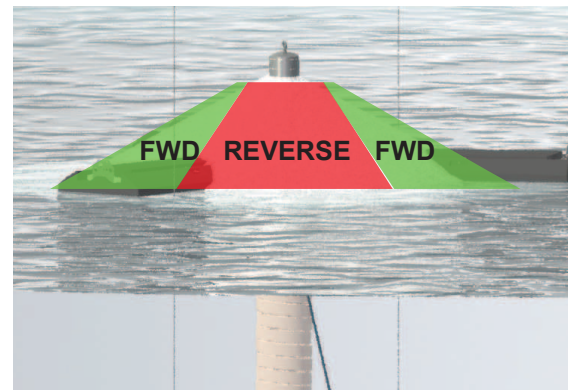

Figure 1: Flow Check

SN Troubleshooting - Wiring

Operation

For suspected issues regarding SN Spray Unit operation, observing and recording motor current and voltage during operation is a good starting point. The normal operating values can be referenced from initial Startup & Operation records and/or from the Wiring document. In addition to motor voltage and current measurements, with power isolated, continuity (ohm) value measurements are helpful in pinpointing issues.

Check	Reading			
Flow Check Visual				
Flow Check Auditory				
<i>Electric measurements should only be performed by qualified personnel</i>	Single Phase	Three Phase Only		
Source Voltage Reading (while unit is running)	L1:L2	L1:L2	L2:L3	L3:L1
Amperage Reading (while unit is running) Reference Wiring Full Load / Max Load	L1	L1	L2	L3
Continuity Check (Motor Windings + Splice + Wire) Reference Wiring for Line to Line Ohms	L1:L2	L1:L2	L2:L3	L3:L1
Discontinuity Check (Power to Ground) Should be Open to Ground	L1: GND	L1: GND	L2:GND	L3:GND

Symptom	Possible Issue / Remediation
Motor Amperage is low	Blocked pump inlet screen, clean debris from inlet Blocked spray nozzle(s), clean spray nozzle(s) Broken, severely worn coupling between pump and motor, pump and/or motor replacement
Motor Amperage is high	Low / Unbalanced line voltage, check source power Phase loss, check source power Short to ground, check continuity to ground leads, bad electric cord, splice, or motor failure, replace faulty component(s) Motor or pump failure, replace motor and/or pump
Fault Message from Three-Phase Motor Protection device	Reference motor protection device manual for detailed problems/conditions resulting in fault message.

Rotation Check - (Three Phase Only)

If wiring was disconnected during troubleshooting steps, the motor rotation needs to be checked. With someone observing the SN Spray Unit, briefly turn the unit on for several seconds and observe the flow pattern, look for how far out the spray reaches. Turn unit off, isolate power, and have a qualified person switch 2 of the 3 motor leads of outgoing power. Repeat operation again for several seconds and observe the SN Spray Unit flow pattern again. Determine which wiring configuration produced the flow pattern that reaches out the furthest and finalize with that wiring of the outgoing power leads. See Figure 1 for proper flow direction.

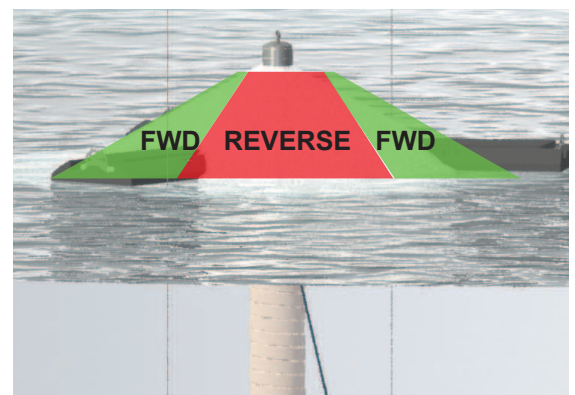

Figure 1: Flow Check

Technical Data Sheet

SN5

Technology Description- Floating, electric powered, circulation and Trihalomethane (THM) removal equipment for potable water tanks and reservoirs. Designed for continuous operation and Factory installed through 18-inch sq. minimum clear roof opening.

Materials of Construction - T316 stainless steel, thermoplastic rubber, High Density Polyethylene construction. GridBee® Machines are constructed using safe materials for contact with potable water. See certifications section below.

TTHM Reduction Range - 20% to 70%, dependant on THM Species, Daily Inflow and other variables, see Ixom for proposal.

Spray Unit Direct Flow Rate - 0.33 Million Gallons Per Day, MGD. *Ixom application engineering evaluations often require sizing systems based on site specific conditions and NOT the spray aeration direct flow rate.*

Minimum Access Opening - Machine can be placed through 18 inch (0.5m) diameter opening.

Minimum Water Depth - Minimum of 4ft (1.2m) operating depth required, do not operate out of water.

Minimum Head Space - Minimum of 24in (0.6m) head space between water level and reservoir/tank ceiling required.

Intake - 20 to 100+ feet (6 to 30+ m) available in 6-inch (15.2 cm) diameter X 20 feet (6 m) sections, thermoplastic rubber, NSF/ANSI 61 approved. Includes low elevation intake that draws water in a horizontal layer within 6 inches (15 cm) of the tank or reservoir floor. Includes intake retrieval chain constructed of 316 stainless steel.

Electrical Requirements - Requires 240VAC/1PH, 208VAC/3PH, 240VAC/3PH or 480VAC/3PH, 60Hz power. Ixom recommends secondary disconnect to be located near equipment access hatch. Optional Franklin SubMonitor three-phase motor protection unit highly recommended and available from Ixom. *All switches, breakers, emergency stop buttons, control panels and other controls shall be installed in accordance to all NEC, State, and local regulations. (Not supplied by Ixom.)*

Motor - 5HP stainless steel submersible, designed for continuous operation, low power requirement, direct drive, no gearbox and no lubrication schedule required. See certifications section below.

Wiring - 4-conductor, submersible power cable for submersible motor wiring terminated exterior at top of tank.

Sealed Penetration Fitting - T316 stainless steel tank fitting with a 3/4" NPT female connection. Not designed as a submersible penetration.

Shipping Size / Weight

• **Crate** - 72in x 16in x 16in (1.83m x 0.41m x 0.41m) / 100lbs (46kg) *Exact weight and dimensions varies dependent on machine configuration.*

Certifications - Ixom's potable water products are certified to ANSI/NSF Standard 61, and 372 for lead-free content. Learn more at: www.ixomwatercare.com/std61

Maintenance / Warranty - Limited maintenance. Limited 2-year parts and labor warranty. See Warranty Statement for details.

Patent Pending

Subject to change without notice.

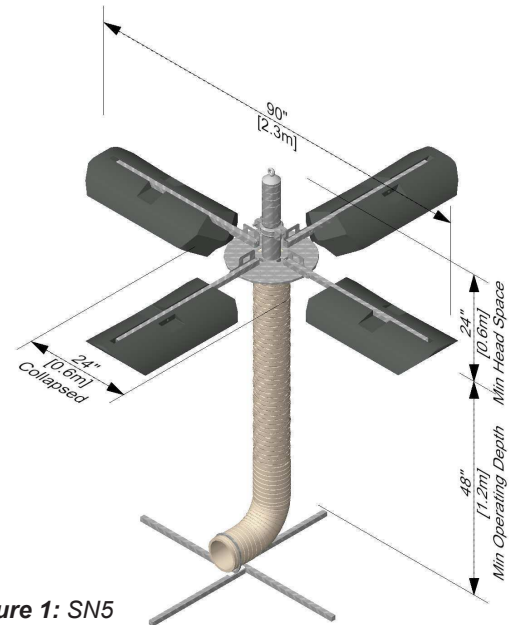
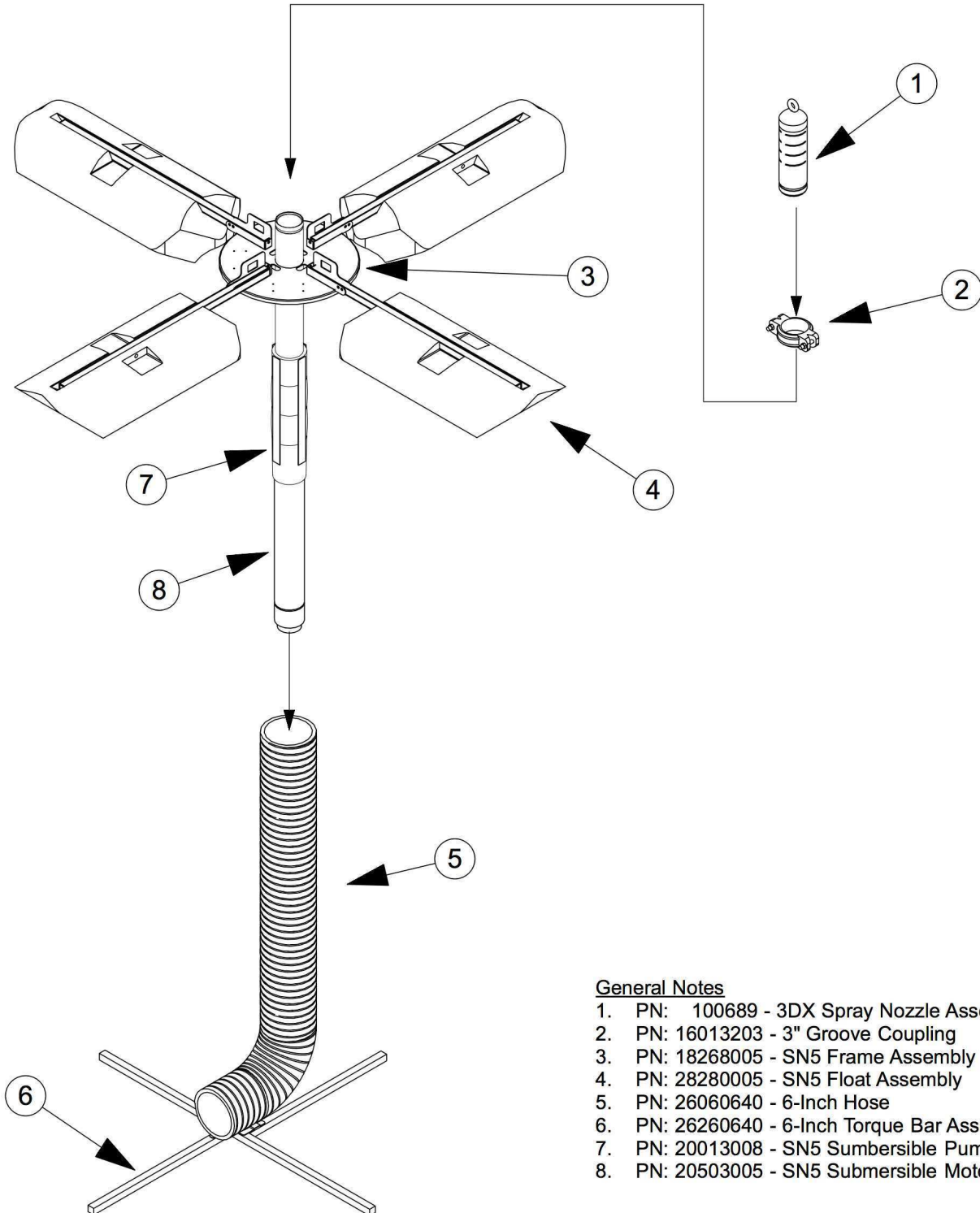

Figure 1: SN5

Exploded Parts Diagram

SN5

Exploded Parts Diagram



General Notes

1. PN: 100689 - 3DX Spray Nozzle Assembly
2. PN: 16013203 - 3" Groove Coupling
3. PN: 18268005 - SN5 Frame Assembly
4. PN: 28280005 - SN5 Float Assembly
5. PN: 26060640 - 6-Inch Hose
6. PN: 26260640 - 6-Inch Torque Bar Assembly
7. PN: 20013008 - SN5 Submersible Pump
8. PN: 20503005 - SN5 Submersible Motor

Dimension Drawing

SN5

Dimension Drawing

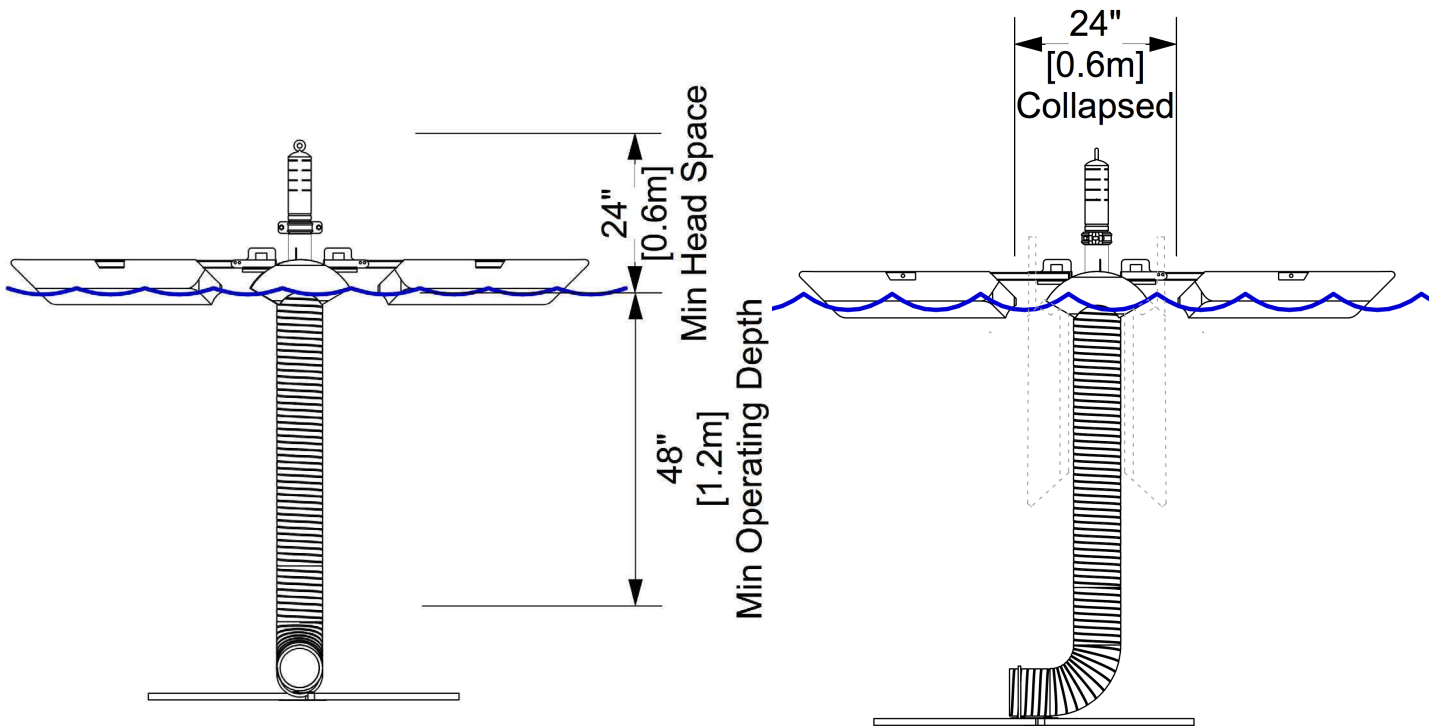
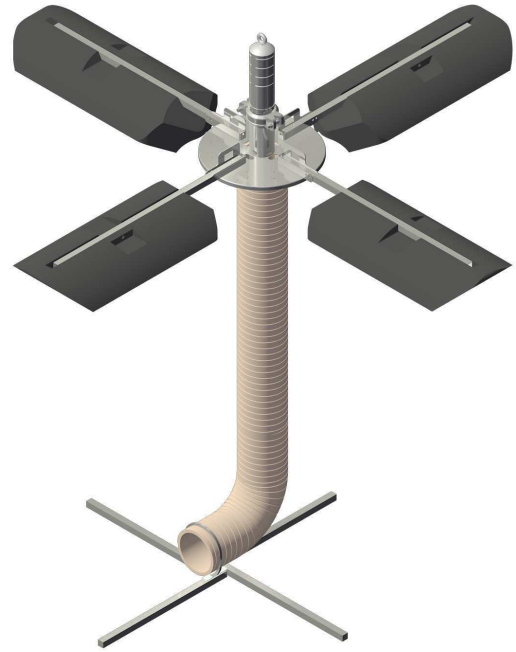
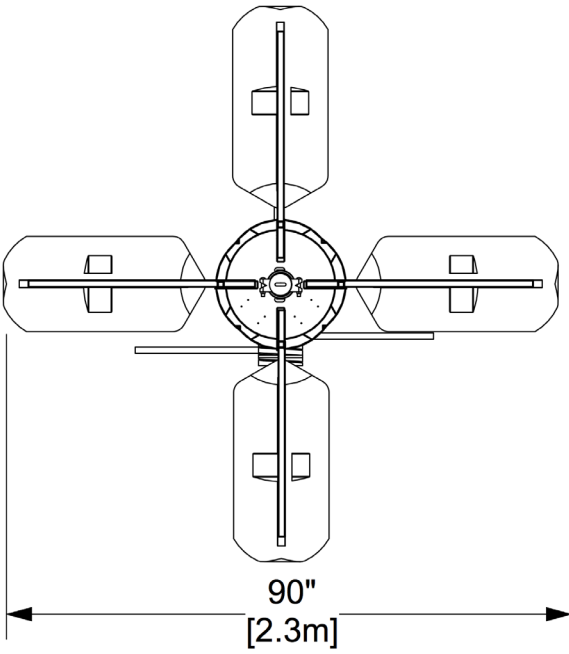

Placement Record



SN Series

Placement Recording

Throughout the placement, recording of various details of the equipment and placement are recommended. This record will serve as a future reference should any equipment issues arise at a later date. The following form is an example of an placement record for this equipment.

<i>DATE</i>	<i>CREW</i>	<i>LOCATION / FACILITY / NAME / CELL # / LOCATION NUMBER</i>
-------------	-------------	--

SPRAY NOZZLE PLACEMENT FIELDSHEET

Spray Unit Model:
Spray Unit SN:
Motor SN:
Pump SN:
Nozzle Type:
Nozzle Type:
Anchoring IF Vertical Cable-Mooring Block, Length of Cable IF other, describe in Notes or separate sheet.

Hose	
Hose Diameter	Hose Length
	top
	bottom
IN TANK ELEC. CORD Length (ft)	
Take Pictures of: Placement Process, Lifting, Spray Unit Placed, Power Panels, Junction Boxes, Tank, Hatches, Safety, Vents, Overflow, Other, Etc.	

AFTER Splice Connection PRIOR To Start Up
Phase 1:2 (Ohms)
Phase 2:3 (Ohms)
Phase 1:3 (Ohms)
Ground: Phase 1 (Ohms)
Ground: Phase 2 (Ohms)
Ground: Phase 3 (Ohms)
AFTER Start Up
Forward Pressure (psi)
Reverse Pressure (psi)
Have Electrician Check
Operating Voltage
Operating Current

NOTES:

Warranty



GridBee THM Removal Systems

Limited Replacement Warranty

GridBee SN Spray Units. GridBee SN Spray Units and blowers are warranted to be free of defective parts, materials, and workmanship for a period of two years from the date of purchase. The optional control panels, by other manufactures, are covered by a manufacturer's warranty of one year from date of purchase. This warranty is valid only for use of the GridBee THM Removal System in accordance with the owner's manual and any initial and ongoing factory recommendations. This warranty is limited to the repair or replacement of defective components only and does not apply to normal wear and tear. If the factory's service crews performed the original on-site placement and startup, then this warranty also includes labor. Where labor is included, in lieu of sending a factory service crew to the site for minor repairs, Ixom may choose to send the replacement parts to the owner postage-paid and may pay the owner a reasonable labor allowance, as determined solely by Ixom, to install the parts. There is no liability for consequential damages of any type. The warranty that is submitted and provided with the purchased equipment is the valid warranty.

GridBee control panels, and any optional accessories. These items are considered "buyout" items for Ixom, and as such include a warranty against defects in material and workmanship for one year from the date of purchase. This warranty covers parts only, not labor. Parts that are determined by Ixom to be defective in material or workmanship under normal use during the one year warranty period will be repaired or replaced. Shipping charges are the responsibility of the customer.

Terms applicable to all equipment. This Limited Replacement Warranty is subject to the terms of Ixom's General Terms and Conditions of Sale. In the event of any inconsistency between the terms of this Limited Replacement Warranty and Ixom's General Terms and Conditions of Sale, the terms of this Limited Replacement Warranty shall prevail to the extent of that inconsistency.

Protect Your Investment With The Ixom Service Program

Comprehensive Damage Repair

Damage which occurs to your Ixom manufactured equipment in the normal course of operation will be repaired or replaced including supply and installation of structural repairs and replacement parts in accordance with Ixom's standard terms & conditions.

Trained & Experienced Service Technicians

The Ixom Service Program allows our customers to take advantage of our highly trained service technicians. We have the equipment, experience and training to ensure the machines are well maintained while following OSHA regulations. Our dedication to safety and high level of training has earned us the prestigious SHARP recognition award time and time again. We have the means to safely service the equipment whether in municipal water tanks, lakes, reservoirs, or wastewater ponds & basins.



Guaranteed Annual Onsite Maintenance

Ixom service personnel will perform a minimum of one (1) onsite equipment inspection & maintenance per yearly term of the service contract including mechanical, structural, and electronic components of Ixom manufactured equipment.

On-Site Crew Response for Critical Application and Operational Service Issues

If service issues arise, the customer may be asked to perform a basic machine inspection and discuss results with Ixom's Customer Service Department. In some cases, the customer may be asked to perform minor tasks (i.e., cleaning, basic troubleshooting, and replacing minor parts). If replacement parts are needed, the factory will ship them out at no cost. For more serious application and service issues, Ixom will dispatch service personnel to resolve the issues onsite.



Removal, Storage, and Redeployment of Equipment

For situations when Ixom equipment needs to be removed, stored, and redeployed, services can be offered at a discounted rate.

Access to On-Staff Water Quality Experts

Ixom employs many experts in the water quality field including specialized areas such as limnology, hydrology, wastewater, biology, and engineering. Our water quality personnel are available for data analysis and troubleshooting when you need it.



Contact us for a quote!

Call +1 866-437-8076 or email us at watercare@ixom.com

IXOM

WATERCARE

Nationwide Installation & Service

EVERYONE DESERVES GREAT CUSTOMER SUPPORT

Ixom Watercare earns customer trust with unparalleled service start to finish. Every department in Ixom is dedicated to the support of our Customers and the improvement of water quality. Complete life cycle support is much, much more than a returned phone call or an email. It centers around direct access and communication to those who can help when help is needed from the beginning of a project throughout the life of the equipment.

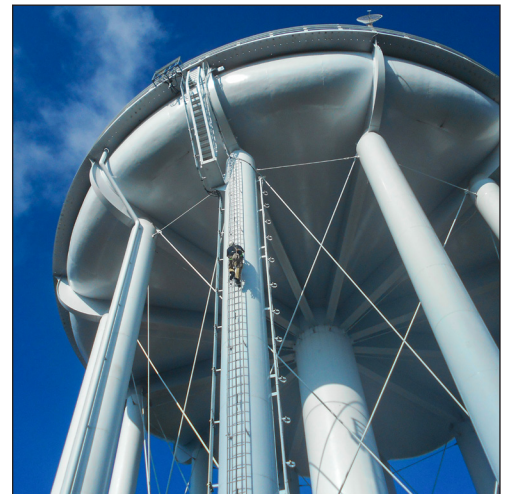

ABOUT IXOM

Ixom combines innovative water quality solutions with top notch manufacturing and nationwide in-field service capabilities to create trusted, full circle support our Customers depend on.

We design and manufacture many trusted brands including GridBee®, SolarBee®, MIEX®, and ResidualHQ® for use across the water quality spectrum. This includes solutions for Water Treatment, Distribution Treatment, Wastewater Treatment and Lakes & Source Water Reservoirs.

Ixom has thousands of installations and is an industry-leader solving water quality problems across the United States, Canada and the world.

Contact us today to discuss your water quality and service needs.

ixomwatercare.com
866-437-8076 • watercare@ixom.com