

AP4000

Operation & Maintenance Manual



Pedestal Configuration



Floating Configuration

Table of Contents



AP4000 Operation & Maintenance Manual

Safety	1
Package Contents	4
Installation	6
Operation	8
Deployment	9
Maintenance	12
Technical Specifications	13
Warranty	14
Service Program	15
Customer Service	16

Safety

IMPORTANT

**YOU MUST COMPLETELY
READ AND FULLY
UNDERSTAND THESE
INSTRUCTIONS BEFORE
INSTALLING, OPERATING,
OR SERVICING THIS UNIT.**

Be sure you have read all installation, operation, maintenance and safety instructions before you install, service or begin to operate this unit.

Accidents occur every year because of careless use of industrial equipment. You can avoid hazards by following these safety instructions, and applying some ordinary common sense when operating or servicing this unit.

Keep in mind that **full operator attention and alertness** are required when operating or servicing this unit.

USE COMMON SENSE!! Most accidents can be avoided by using **common sense and concentration** on the job being done.



Carefully read safety information when you see any safety symbols.



Safety

IMPORTANT

YOU MUST COMPLETELY READ AND FULLY UNDERSTAND THESE INSTRUCTIONS BEFORE INSTALLING, OPERATING, OR SERVICING THIS UNIT.

Identify all possible hazards. Determine what safeguards are needed and implement them. **Only you, the user,** understand your product and system characteristics fully. *The ultimate responsibility for safety is with you. Your safety ultimately rests in your hands.* Do your part and you will enjoy safe, trouble free operation for years to come. This instruction manual is not intended to include a comprehensive listing of all details for all procedures required for placement, operation and maintenance. If you have a question about a procedure or are uncertain about any detail, **Do Not Proceed.** Please contact Ixom Watercare Customer Service at **866-437-8076** to speak to a representative.



IMPORTANT!!!

Follow all federal and state laws in regards to safety regulations of working at heights, confined spaces, rescue, etc. as required by the U.S. Department of Labor, Occupational Safety and Health Administration. Use necessary PPE when placing and servicing this unit.



Thin Ice Hazard

WARNING: ICE SURROUNDING MACHINE MAY NOT SUPPORT WEIGHT, KEEP CLEAR OF THIN ICE.



ELECTRICAL HAZARD

WARNING: THIS EQUIPMENT CONTAINS HIGH VOLTAGE! ELECTRICAL SHOCK CAN CAUSE SERIOUS OR FATAL INJURY. ONLY QUALIFIED PERSONNEL SHOULD ATTEMPT PLACEMENT, OPERATION AND MAINTENANCE OF ELECTRICAL EQUIPMENT. REMOVE ALL SOURCES OF ELECTRICAL POWER BEFORE PERFORMING ANY SERVICE WORK TO THE MACHINE. USE PROPER LOCKOUT TAGOUT (LOTO) PROCEDURES TO ENSURE A SAFE WORK ENVIRONMENT.



Crush Hazard

WARNING: DO NOT REMOVE ANY FLOAT ASSEMBLY BOLTS OR PINS WHILE EQUIPMENT IS FLOATING IN WATER. EQUIPMENT MUST BE SECURELY SUPPORTED BEFORE PERFORMING SERVICE.



Rotating Hazard

CAUTION: KEEP BODY APPENANDAGES OR LOOSE CLOTHING AWAY FROM EQUIPMENT WHILE OPERATING. ENSURE EQUIPMENT IS OFF BEFORE ATTEMPTING SERVICE.



Entanglement Hazard

WARNING: ENSURE THAT PERSONNEL ARE CLEAR OF THE ELECTRIC CORD AND CHAIN TO AVOID ENTANGLEMENT.



Laceration Hazard

CAUTION: EDGES MAY BE SHARP AND CAUSE LACERATION IF PROPER CARE IS NOT USED.

Safety

Protect Yourself

It is important that you comply with all relative OSHA and local regulations while installing and performing any maintenance to the mixer circulation equipment.

Key OSHA Compliance Standards that must be followed (and not limited to) are:

- **1910.146 Permit-required confined spaces**
- **1910.147 Lockout/Tagout**
- **1926.500 Fall Protection**

Fall Protection Tips

- Identify all potential tripping and fall hazards before work starts.
- Look for fall hazards such as unprotected floor openings/edges, shafts, open hatches, stairwells, and roof openings/edges.
- Inspect fall protection and rescue equipment for defects before use.
- Select, wear, and use fall protection and rescue equipment appropriate for the task.
- Secure and stabilize all ladders before climbing.
- Never stand on the top rung/step of a ladder.
- Use handrails when you go up or down stairs.
- Practice good housekeeping. Keep cords, welding leads and air hoses out of walkways or adjacent work areas.

Refer to 29 CFR 1926.500 for complete regulations set by OSHA. Refer to your state's regulations if your state established and operates their own safety and health programs approved by OSHA.

Lockout Tagout

When the On/Off switch is in the "ON" position, the mixer may start up at any time if not already operating. The mixer's On/Off switch can be locked out by placing a pad lock thru the door latch of the controller after the switch has been turned to the "OFF" position. The On/Off switch is to be used as the emergency stop.



Permit-Required Confined Spaces

A confined space has limited openings for entry or exit, is large enough for entering and working, and is not designed for continuous worker occupancy. Confined spaces include underground reservoirs, ground storage tanks, elevated tanks, silos, manholes, and pipelines.

Confined Space Tips

- Do not enter permit-required confined spaces without being trained and without having a permit to enter.
- Review, understand and follow employer's procedures before entering permit-required confined spaces and know how and when to exit.
- Before entry, identify any physical hazards.
- Before and during entry, test and monitor for oxygen content, flammability, toxicity or explosive hazards as necessary.
- Use fall protection, rescue, air monitoring, ventilation, lighting and communication equipment according to entry procedures.
- Maintain contact at all times with a trained attendant either visually, via phone, or by two-way radio. This monitoring system enables the attendant and entry supervisor to order you to evacuate and to alert appropriately trained rescue personnel to rescue entrants when needed.

Refer to 29 CFR 1910.146 for complete regulations set by OSHA. Refer to your state's regulations if your state established and operates their own safety and health programs approved by OSHA.

Package Contents

Contents

AP4000 - Pedestal Configuration



Connection Kit



**50' T316SS Chain
(Retrieval Chain)**



**10" Float Ball
T316SS Sphere**

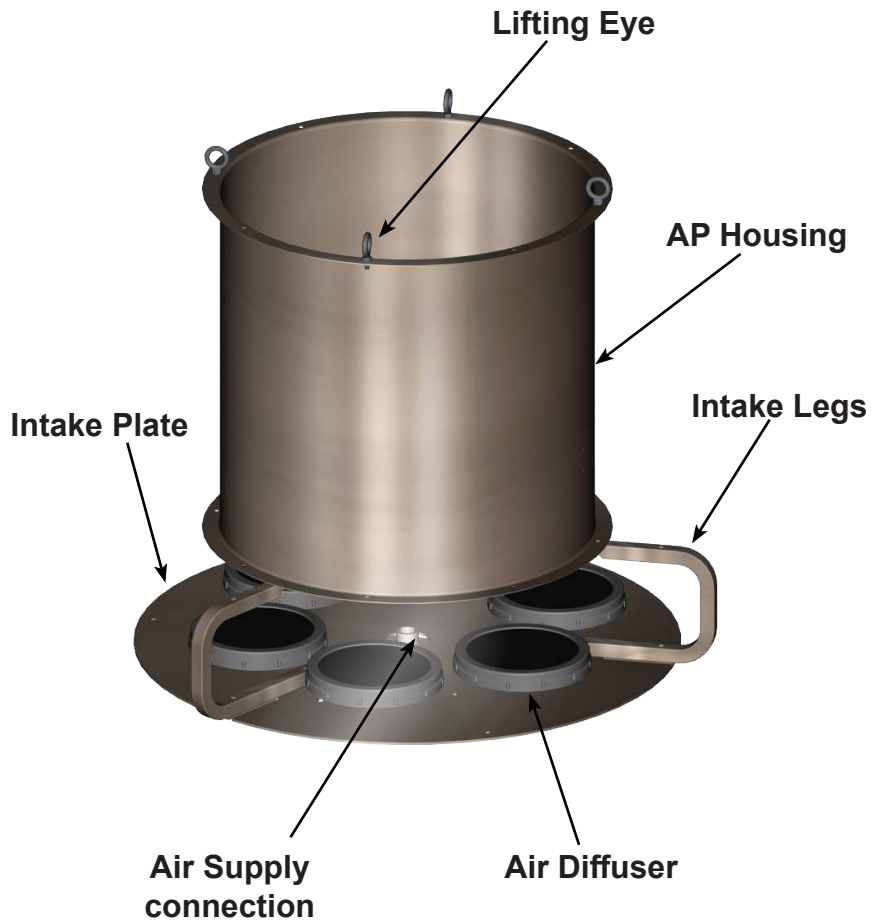

Optional Accessories:

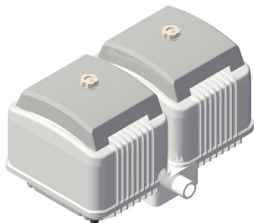

**AU-400
Water depth <10'**

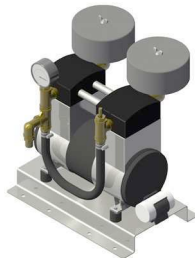

**AC-1080
Water depth >10'**



100' Air Hose

**Extension Legs
Also Available**

Package Contents

Contents

AP4000 - Floating Configuration



Connection Kit



10' T316SS Chain (Retrieval Chain) plus 4 - 1' lengths

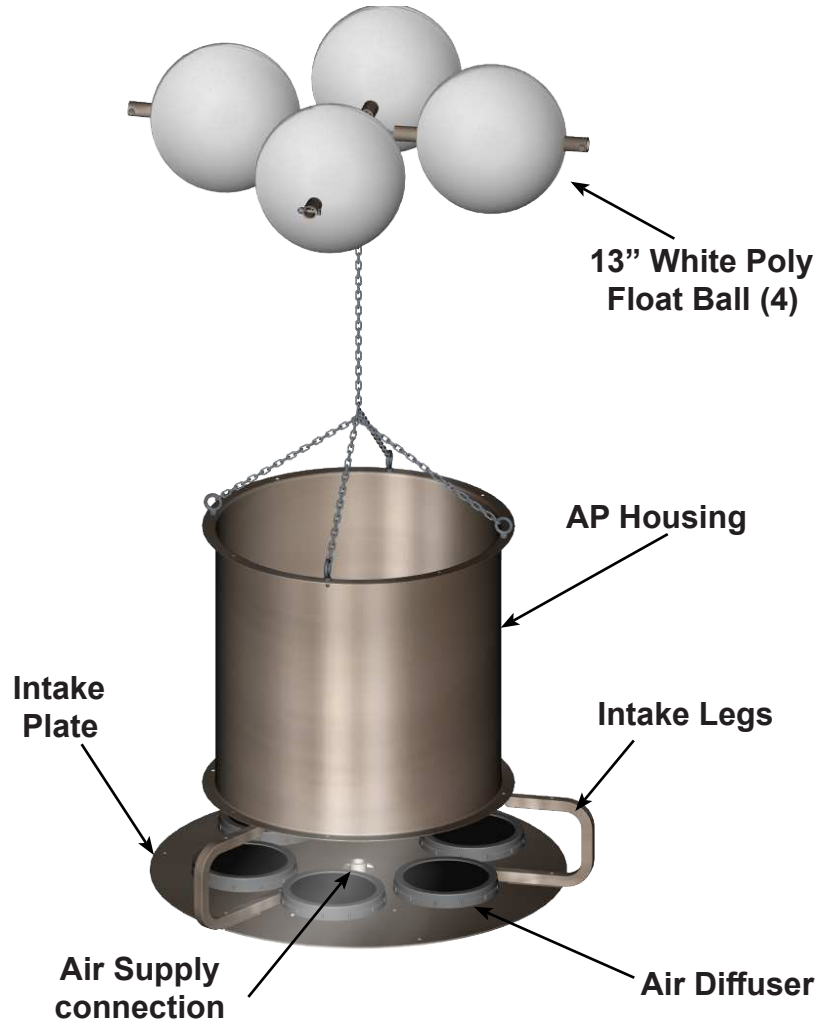

Optional Accessories:

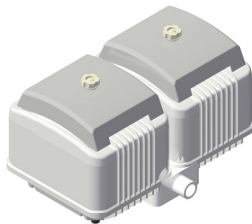

AU-400
Water depth <10'

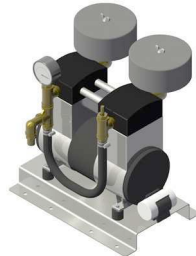

AC-1080
Water depth >10'



100' Air Hose

Installation

Unit Installation

AP4000 - Pedestal

TOOLS REQUIRED

- Pliers
- 5/16" Nut Driver
- 13mm Socket Wrench and Open End Wrench

INTAKE LEGS / INTAKE PLATE ASSEMBLY

1. Attach the Intake Legs to the housing of the AP unit with the bolts provided.
2. Attach the Intake Plate to the bottom of the Intake Legs.
3. Attach the Optional 10" Float Ball with retrieval chain to the housing to one of the eyebolts with the quicklinks provided. (See Figure 1)

ANCHORING

For pedestal configurations, the weight of the unit is adequate for holding the unit in place when resting on the bottom. In some applications, suspending the unit from and structure above will work, just be sure to use the dedicated lifting eyelets or eyebolts.

OPTIONAL HOSE ASSEMBLY AND ATTACHMENT

For attaching hoses to the unit, assemble using Quick Connector Center in the barrel of the unit. Prior to tightening hose clamp, be sure that the clamp is located above the barb on the hose flange to prevent the hose from slipping off the flange during operation.

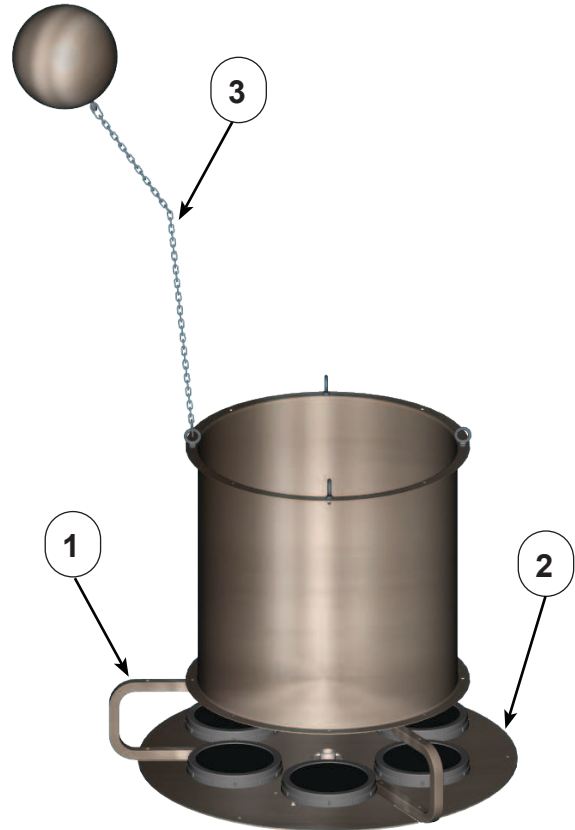

Figure 1: AP Unit Pedestal Configuration

Installation

Unit Installation

AP4000 - Floating

TOOLS REQUIRED

- Pliers
- 5/16" Nut Driver
- 13mm Socket Wrench and Open End Wrench

INTAKE LEGS / INTAKE PLATE ASSEMBLY

1. Attach the Intake Legs to the housing of the AP unit with the bolts provided.
2. Attach the Intake Plate to the bottom of the Intake Legs.
3. Using quick links, attach the chains to the unit using the 4 attached eye bolts. Be sure to tighten quick links with pliers. (See Figure 1)

OPTIONAL FLOAT BALL ATTACHMENT

For attaching float balls, locate the 1' float chains and slide through the float pipe and add stop bolt at the top after measuring out desired manifold submergence depth. The float ball will sit approximately 1/2 of the way submerged in water. Be sure to tighten the stop bolt to prevent the chain from sliding down through the pipe of the float ball. (See Figure 2)

ANCHORING

For floating configurations additional anchoring systems may be required, such as mooring or tethering, to keep the unit in position within the pond or basin. In some applications, suspending the unit from a structure above will work, just be sure to use the dedicated lifting eyelets or eyebolts.

OPTIONAL HOSE ASSEMBLY AND ATTACHMENT

For attaching hoses to the unit, assemble using hose clamp and 5/16" nut driver on each end. Prior to tightening hose clamp, be sure that the clamp is located above the barb on the hose flange to prevent the hose from slipping off the flange during operation.

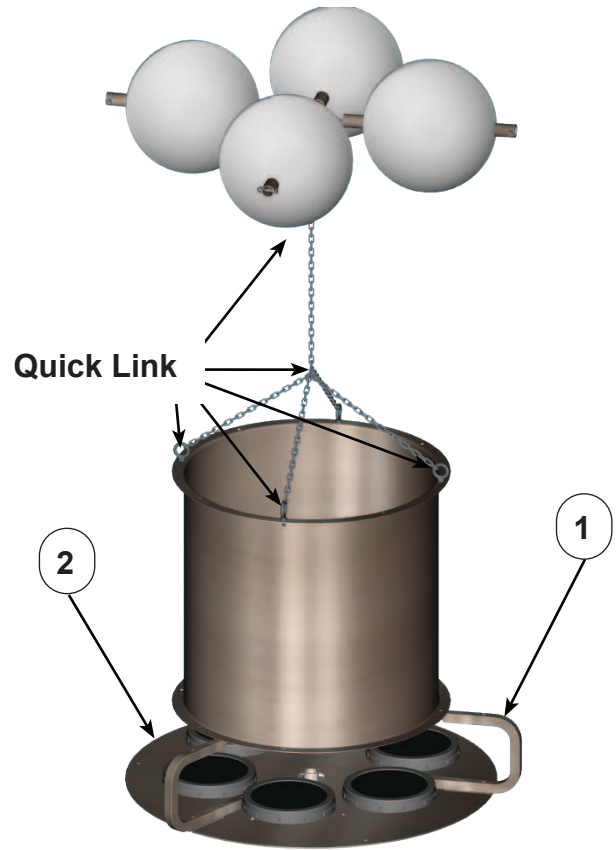

Figure 1: AP Unit Floating Configuration

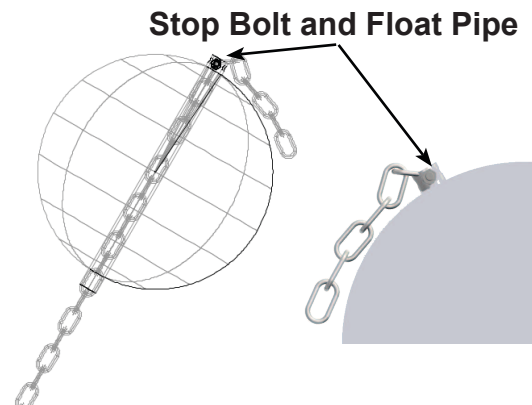

Figure 2: AP Unit Float Assembly

Operation

Unit Operation

AP4000

BASIC OPERATION

The AP Unit is designed to circulate water by bringing water from below and sending it out across the top in a thin layer causing a mixing effect.

The air diffuser creates thousands of tiny bubbles which produces a "Low Pressure Zone" that creates an uplift suction flow through the intake draft tube, and a slight mound at the water surface, producing gentle flow radially outward from the AP Unit.

The water layers flow outward radially, in diverging "stream lines" from the unit. As it does, vertical flow is induced in between the water being drawn below and the water above. At the level of the flow intake, water is drawn from all corners of the pond. As this lower layer of fluid makes its way inward with converging streamlines to the AP Unit, the water is forced upward, toward the surface, providing gentle mixing, de-stratification, and surface renewal.

The AP Unit requires a minimal amount of supplied air. The air is supplied to the AP Unit with the optional air feed hose that connects to air manifold.

It is acceptable to use the AP Unit on an as needed or required basis. This will allow for reduced power consumption and will benefit in energy savings. This will require the AP Unit to run on a timer or local SCADA system.

Refer to air supply manufacturer for recommended duty cycle and other operational recommendations and constraints.

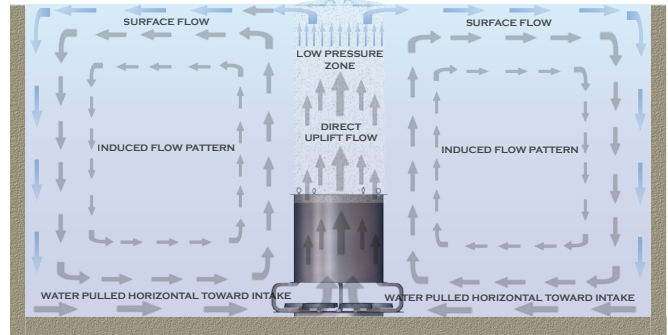

Figure 1: AP Unit Pedestal Configuration Flow Pattern

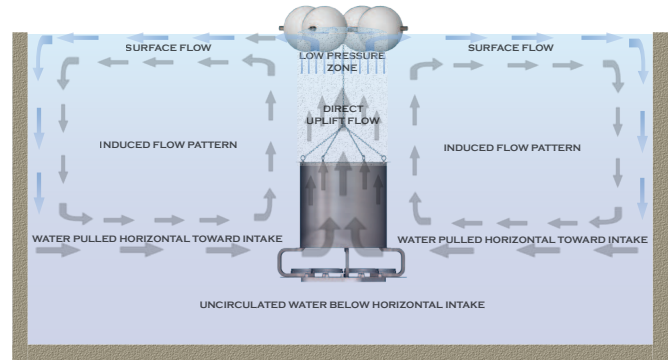

Figure 2: AP Unit Floating Configuration Flow Pattern



Figure 3: Flow Leaving AP Unit

Deployment

Deployment

AP Series

Machine Deployment

1. Lay out hose from air unit location to edge of water. Air unit should be located a safe distance away from waters edge.
2. Attach end of air hose to AP machine.
3. Attach anchor chain to unit at the desired distance from the surface with quick link. If anchor chain is longer than needed, you do not need to cut it to length.
4. Attach air hose to air unit.
5. Deploy machine in desired spot by first lowering in machine and then lower the machine slowly using the anchor chain to the desired depth.
6. Plug in air unit and ensure that air is coming out of the machine. You should see flow coming out of the machine after 15 seconds.

Adjusting Intake Depth

To adjust the intake depth you must adjust the anchor chain. The anchor chain is connected to the top of the unit and the float(s). To raise the intake depth, shorten the anchor chain and to lower the intake depth, lengthen the anchor chain. To set intake depth, the anchor chain should be 30" less than desired intake measurement.

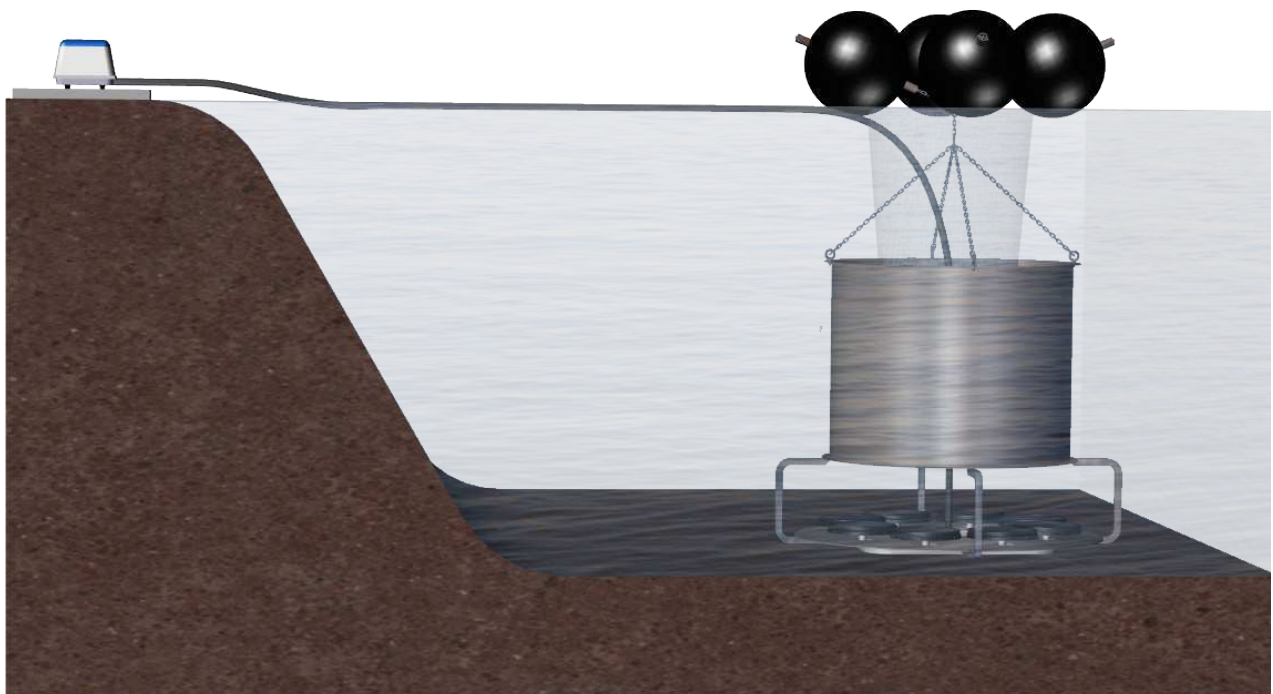

Figure 1: Typical Deployment (Not to scale) Air unit should be located away from water. Model May Vary.









Deployment

Deployment

AP Series

Hardware Kit: Includes fittings for AP Machine and Air Supply Connections.

Part Number	Size
100675*	3/4"
100673	1"
100672	1 1/2"
1415364	2"

No.	Description	Qty.	Image
1	Quick Coupling, Male Cam Lock (Included on Machine Assembly)	1	
2*	Hose Barb, Female Cam Lock	1	
3	Zip Ties	4	
4	Hose Clamp	2	
5	Hose Barb, Male Cam Lock	1	
6	Quick Coupling, Female Cam Lock	1	
7**	Reducer Bushing, 2" MNPT x 1.5" FNPT	1	
8**	Quick Coupling, Male Cam Lock x FNPT	1	



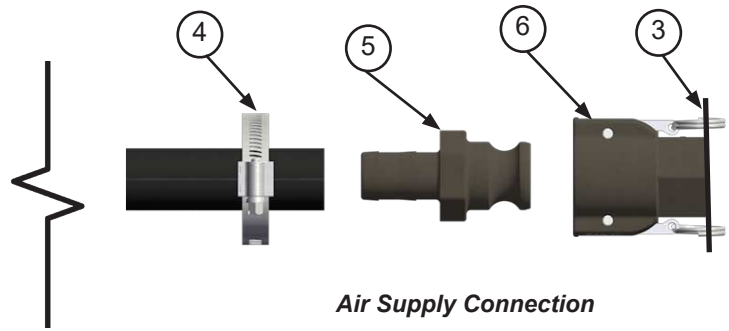
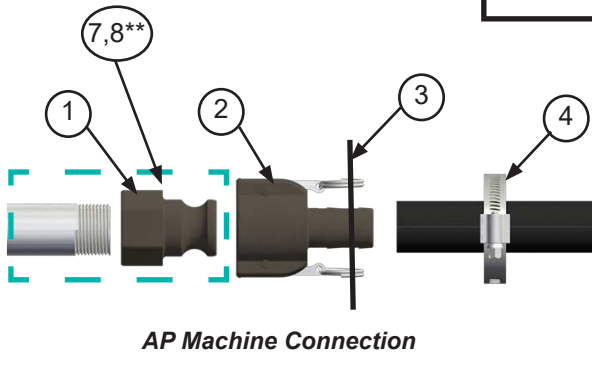

* Some configurations require a 2 piece fitting. (Not pictured)
** Included with 2" hose option only (Customer installed)



Hose Splice Connection Hardware Kit

Part Number	Size
100679	3/4"
100680	1"
100681	1 1/2"
1415370	2"

Subject to change without notice.

No.	Description	Qty.	Image
1	Hose Clamp	2	
2	Zip Ties	2	
3	Quick Coupling, Female Cam Lock	1	
4	Hose Barb, Male Cam Lock	1	

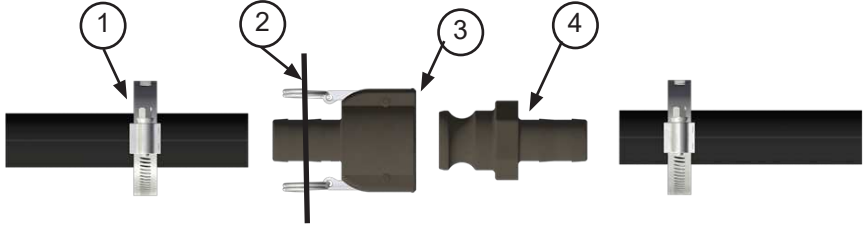

Hose Splice Connection

Deployment

Deployment

AP Series

Tee Fitting Kit

Part Number	Size
100650	3/4"
100652	1"
100654	1 1/2"
1415371	2"

No.	Description	Qty.	Image
1	Hose Clamp	2	
2	Hose Barb	2	
3	Close Nipple	3	
4	Pressure Gauge	1	
5	Reducer Bushing	1	
6	Tee	1	
7	Ball Valve	1	

** Tee Fitting Kit included when customer supplies air source.*

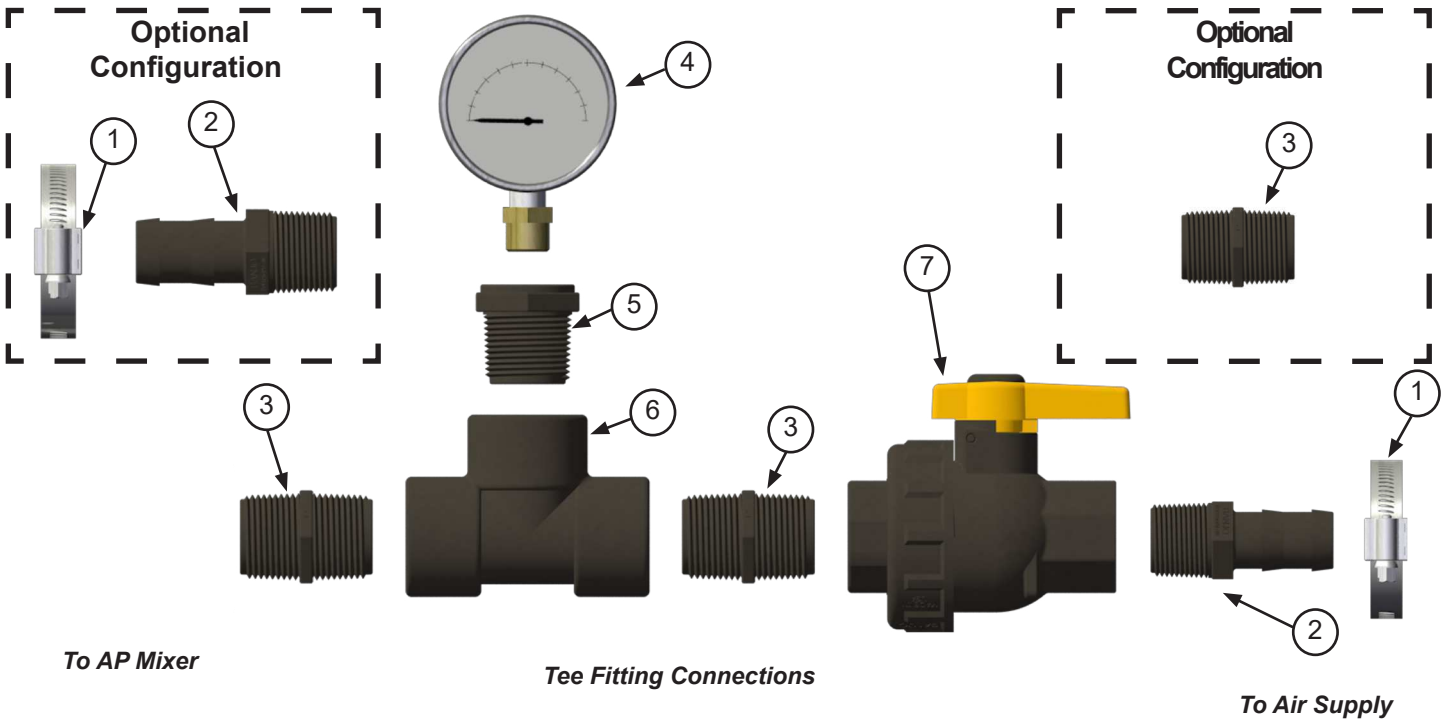

Maintenance

Maintenance

AP4000

UNIT CLEANING

The AP Unit is designed to provide continuous operation with little to no maintenance. However, in some locations significant debris within the pond may eventually get caught on the unit either restricting the flow pattern at the manifold or through the intake housing.

Debris may get caught in the air manifold, either being too large to pass through or resistant to sliding up the manifold housing. Often debris will eventually work it's way loose and pass through the unit or may be pulled through as other debris passing through the unit will pull or slide snagged debris through. If significant debris is causing the unit to clog, occasional maintenance and cleaning may be required.

If required, debris should be carefully removed from the manifold and be wiped clean from any scum buildup on the outside of the pipes that may contribute to preventing debris from passing through the unit.

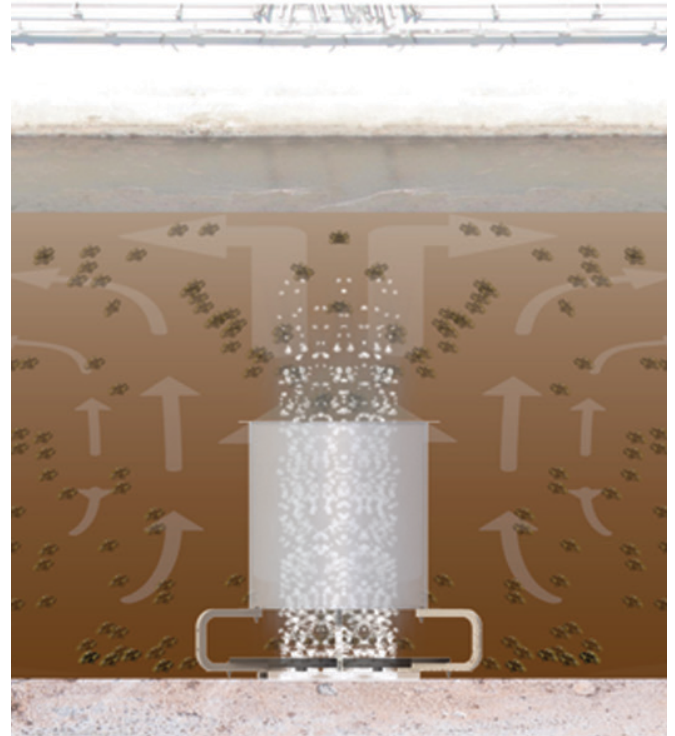

Figure 1: Debris Passing Through AP Unit.

WINTER CONDITION RECOMMENDATIONS

For locations where there may be public access or recreation such as ice fishing, snowmobile traffic, or other activities on the water body during winter, **ixom strongly recommends removing the AP Unit from the water body or, at minimum, turning the unit off** in the late fall before freeze up. If the unit isn't removed, but is at least turned off, the area around the unit would then freeze in solid as the rest of the lake does, decreasing the chance of a serious accident near the machine.

If these recommendations are not followed, the AP Unit will cause thin ice several meters around the vicinity, creating a very large hazardous area.

Technical Data Sheet

AP4000

Technology Description- GridBee® air powered circulation equipment are made of corrosion resistant, 316 stainless steel with a durable clog-free design and no moving parts for low maintenance. The AP4000 stays out of sight but allows for mixing of small ponds and lake with no part of the machine above the water. Specifically designed for small ponds and docks.

Materials of Construction - T316 stainless steel frame and hardware. EPDM and PVC air hose and polypropylene air hose fittings. (See Figure 1)

10 ft (15.24 m) T316 stainless steel retrieval chain included for machine retrieval.

Recommended Air Flow - 6 to 30 standard cubic feet per minute (0.17 to 0.85 standard cubic meters per minute) @ 1psi (7.0 kiloPascal) + head pressure of water height above intake plate level. 1" MNPT Air connection point.

Minimum Water Depth - Machine requires 36 inches (0.92M) of water to effectively circulate. No damage to machine when run dry in shallow water or drained condition.

Maximum Water Depth - Maximum air discharge depth is limited by the air supply pressure available.

Intake - The submergence depth on a pedestal unit is simply set by either the floor it rests on or for a suspended unit by the vertical suspending cable or chain.

Flotation Accessory - Floating option available, float balls and short chain included to allow for adjustable intake depth with respect to water surface.

(Optional Accessory)AU-400 Pump Unit - 560 watt rated air pump unit capable of producing 11.0 cubic feet per minute (0.31 cubic meters per minute) @ 2.5 psi (17 kiloPascal). 100% duty-cycle. 6ft AC pigtail cord plugs into standard 120vAC, 20 Amp Service. Sound Level: 52dB Connection: 3/4" NPT Thread. (See Figure 2)

Electrical Requirements - Optional AU-400 Air pump requires 120VAC/1PH power source outlet (minimum 20 Amp service), Current range: 7.5 amps (open discharge) - 3.7 (dead head).

Enclosed Area Warning - Air powered mixers should not be used in enclosed areas where methane or other explosive gases could build up. Some gases can explode when combined with air. Please verify that you have proper ventilation to prevent a buildup of methane gas or other gases in the headspace above the explosion limit.

Maintenance / Warranty- Limited maintenance. Limited manufacture's warranty. See Warranty Statement for details.

Patent Pending

©2024 IXOM Watercare Inc. | www.ixomwatercare.com | 866 - 437 - 8076 | watercare@ixom.com

1718_10091_20240412

Subject to change without notice.

O&M_AP4000_10096_20240412 - 13

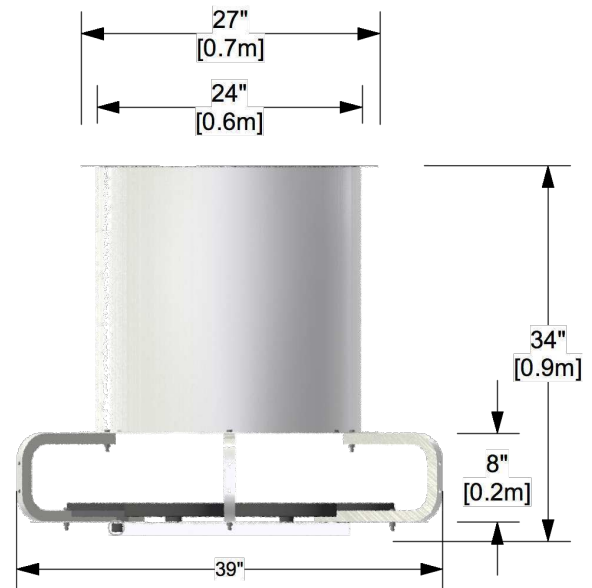

Figure 1: AP4000

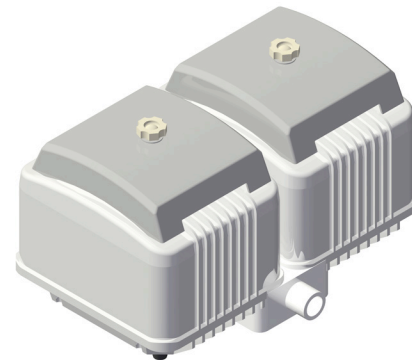

Figure 2: AU-400

Shipping Size/Weight

- **AP4000** - 42" x 42" x 48", 150lbs.
- **AU-400** - 12" x 16" x 10.5", 60lbs. (Optional)
- **100 ft Air Hose** - 36lbs. (Optional)

Warranty



GridBee AP Mixers

Limited Replacement Warranty

GridBee AP Mixers. These units are warranted to be free of defective parts, materials, and workmanship for a period of two years from the date of installation. This warranty is limited to the repair or replacement of defective components only and does not apply to normal wear and tear. If the factory's service crews performed the original on-site placement and startup, then this warranty also includes labor. Where labor is included, in lieu of sending a factory service crew to the site for minor repairs, Ixom may choose to send the replacement parts to the owner postage-paid and may pay the owner a reasonable labor allowance, as determined solely by Ixom, to install the parts.

GridBee air pumps, air compressors, control panels, and any optional accessories. These items are considered "buyout" items for Ixom, and as such include a warranty against defects in material and workmanship for one year from the date of purchase. This warranty covers parts only, not labor. Parts that are determined by Ixom to be defective in material or workmanship under normal use during the one year warranty period will be repaired or replaced. Shipping charges are the responsibility of the customer.

Terms applicable to all equipment. This Limited Replacement Warranty is subject to the terms of Ixom's General Terms and Conditions of Sale. In the event of any inconsistency between the terms of this Limited Replacement Warranty and Ixom's General Terms and Conditions of Sale, the terms of this Limited Replacement Warranty shall prevail to the extent of that inconsistency.

Protect Your Investment With The Ixom Service Program

Comprehensive Damage Repair

Damage which occurs to your Ixom manufactured equipment in the normal course of operation will be repaired or replaced including supply and installation of structural repairs and replacement parts in accordance with Ixom's standard terms & conditions.

Trained & Experienced Service Technicians

The Ixom Service Program allows our customers to take advantage of our highly trained service technicians. We have the equipment, experience and training to ensure the machines are well maintained while following OSHA regulations. Our dedication to safety and high level of training has earned us the prestigious SHARP recognition award time and time again. We have the means to safely service the equipment whether in municipal water tanks, lakes, reservoirs, or wastewater ponds & basins.



Guaranteed Annual Onsite Maintenance

Ixom service personnel will perform a minimum of one (1) onsite equipment inspection & maintenance per yearly term of the service contract including mechanical, structural, and electronic components of Ixom manufactured equipment.

On-Site Crew Response for Critical Application and Operational Service Issues

If service issues arise, the customer may be asked to perform a basic machine inspection and discuss results with Ixom's Customer Service Department. In some cases, the customer may be asked to perform minor tasks (i.e., cleaning, basic troubleshooting, and replacing minor parts). If replacement parts are needed, the factory will ship them out at no cost. For more serious application and service issues, Ixom will dispatch service personnel to resolve the issues onsite.



Removal, Storage, and Redeployment of Equipment

For situations when Ixom equipment needs to be removed, stored, and redeployed, services can be offered at a discounted rate.

Access to On-Staff Water Quality Experts

Ixom employs many experts in the water quality field including specialized areas such as limnology, hydrology, wastewater, biology, and engineering. Our water quality personnel are available for data analysis and troubleshooting when you need it.



Contact us for a quote!

Call +1 866-437-8076 or email us at watercare@ixom.com

IXOM

WATERCARE

Nationwide Installation & Service

EVERYONE DESERVES GREAT CUSTOMER SUPPORT

Ixom Watercare earns customer trust with unparalleled service start to finish. Every department in Ixom is dedicated to the support of our Customers and the improvement of water quality. Complete life cycle support is much, much more than a returned phone call or an email. It centers around direct access and communication to those who can help when help is needed from the beginning of a project throughout the life of the equipment.

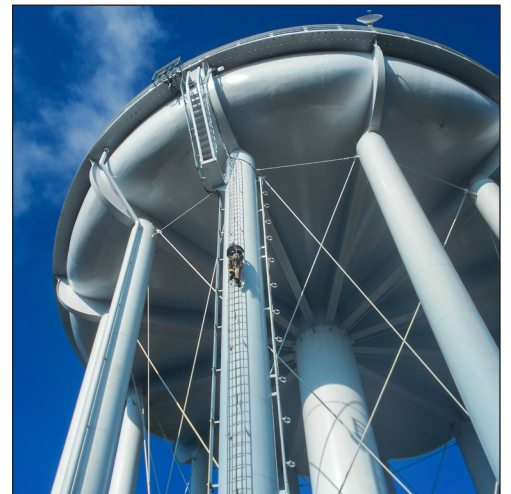

ABOUT IXOM

Ixom combines innovative water quality solutions with top notch manufacturing and nationwide in-field service capabilities to create trusted, full circle support our Customers depend on.

We design and manufacture many trusted brands including GridBee®, SolarBee®, MIEX®, and ResidualHQ® for use across the water quality spectrum. This includes solutions for Water Treatment, Distribution Treatment, Wastewater Treatment and Lakes & Source Water Reservoirs.

Ixom has thousands of installations and is an industry-leader solving water quality problems across the United States, Canada and the world.

Contact us today to discuss your water quality and service needs.

ixomwatercare.com
866-437-8076 • watercare@ixom.com