

# **GridBee GS-12**

## 120V Single Phase

### Operation & Maintenance Manual



# Table of Contents



## GridBee GS-12 120V Single Phase Operation & Maintenance Manual

---

Safety Instructions	1
Package Contents	4
Machine Requirements	5
Top of Tank Junction Box	6
Placement	9
Final Checklist	12
Troubleshooting	13
Technical Specifications	15
Warranty	16
Service Program	17
Customer Service	18

---

## Safety

# IMPORTANT

**YOU MUST COMPLETELY  
READ AND FULLY  
UNDERSTAND THESE  
INSTRUCTIONS BEFORE  
INSTALLING, OPERATING,  
OR SERVICING THIS UNIT.**

**Be sure you have read all installation, operation, maintenance and safety instructions before you install, service or begin to operate this unit.**

Accidents occur every year because of careless use of industrial equipment. You can avoid hazards by following these safety instructions, and applying some ordinary common sense when operating or servicing this unit.

Keep in mind that **full operator attention and alertness** are required when operating or servicing this unit.

**USE COMMON SENSE!!** Most accidents can be avoided by using **common sense and concentration** on the job being done.



Carefully read safety information when you see any safety symbols.



# Safety

## IMPORTANT

**YOU MUST COMPLETELY READ AND FULLY UNDERSTAND THESE INSTRUCTIONS BEFORE INSTALLING, OPERATING, OR SERVICING THIS UNIT.**

Identify all possible hazards. Determine what safeguards are needed and implement them. **Only you, the user,** understand your product and system characteristics fully. *The ultimate responsibility for safety is with you. Your safety ultimately rests in your hands.* Do your part and you will enjoy safe, trouble free operation for years to come. This instruction manual is not intended to include a comprehensive listing of all details for all procedures required for placement, operation and maintenance. If you have a question about a procedure or are uncertain about any detail, **Do Not Proceed.** Please contact Ixom Watercare Customer Service at **866-437-8076** to speak to a representative.



### IMPORTANT!!!

Follow all federal and state laws in regards to safety regulations of working at heights, confined spaces, rescue, etc. as required by the U.S. Department of Labor, Occupational Safety and Health Administration. Use necessary PPE when placing and servicing this unit.



### Thin Ice Hazard

**WARNING:** ICE SURROUNDING MACHINE MAY NOT SUPPORT WEIGHT, KEEP CLEAR OF THIN ICE.



### ELECTRICAL HAZARD

**WARNING:** THIS EQUIPMENT CONTAINS HIGH VOLTAGE! ELECTRICAL SHOCK CAN CAUSE SERIOUS OR FATAL INJURY. ONLY QUALIFIED PERSONNEL SHOULD ATTEMPT PLACEMENT, OPERATION AND MAINTENANCE OF ELECTRICAL EQUIPMENT. REMOVE ALL SOURCES OF ELECTRICAL POWER BEFORE PERFORMING ANY SERVICE WORK TO THE MACHINE. USE PROPER LOCKOUT TAGOUT (LOTO) PROCEDURES TO ENSURE A SAFE WORK ENVIRONMENT.



### Crush Hazard

**WARNING:** DO NOT REMOVE ANY FLOAT ASSEMBLY BOLTS OR PINS WHILE EQUIPMENT IS FLOATING IN WATER. EQUIPMENT MUST BE SECURELY SUPPORTED BEFORE PERFORMING SERVICE.



### Rotating Hazard

**CAUTION:** KEEP BODY APPENANDAGES OR LOOSE CLOTHING AWAY FROM EQUIPMENT WHILE OPERATING. ENSURE EQUIPMENT IS OFF BEFORE ATTEMPTING SERVICE.



### Entanglement Hazard

**WARNING:** ENSURE THAT PERSONNEL ARE CLEAR OF THE ELECTRIC CORD AND CHAIN TO AVOID ENTANGLEMENT.



### Laceration Hazard

**CAUTION:** EDGES MAY BE SHARP AND CAUSE LACERATION IF PROPER CARE IS NOT USED.

# Safety

## Protect Yourself

It is important that you comply with all relative OSHA and local regulations while installing and performing any maintenance to the mixer circulation equipment.

Key OSHA Compliance Standards that must be followed (and not limited to) are:

- **1910.146 Permit-required confined spaces**
- **1910.147 Lockout/Tagout**
- **1926.500 Fall Protection**

## Fall Protection Tips

- Identify all potential tripping and fall hazards before work starts.
- Look for fall hazards such as unprotected floor openings/edges, shafts, open hatches, stairwells, and roof openings/edges.
- Inspect fall protection and rescue equipment for defects before use.
- Select, wear, and use fall protection and rescue equipment appropriate for the task.
- Secure and stabilize all ladders before climbing.
- Never stand on the top rung/step of a ladder.
- Use handrails when you go up or down stairs.
- Practice good housekeeping. Keep cords, welding leads and air hoses out of walkways or adjacent work areas.

Refer to 29 CFR 1926.500 for complete regulations set by OSHA. Refer to your state's regulations if your state established and operates their own safety and health programs approved by OSHA.

## Lockout Tagout

When the On/Off switch is in the "ON" position, the mixer may start up at any time if not already operating. The mixer's On/Off switch can be locked out by placing a pad lock thru the door latch of the controller after the switch has been turned to the "OFF" position. The On/Off switch is to be used as the emergency stop.



## Permit-Required Confined Spaces

A confined space has limited openings for entry or exit, is large enough for entering and working, and is not designed for continuous worker occupancy. Confined spaces include underground reservoirs, ground storage tanks, elevated tanks, silos, manholes, and pipelines.

## Confined Space Tips

- Do not enter permit-required confined spaces without being trained and without having a permit to enter.
- Review, understand and follow employer's procedures before entering permit-required confined spaces and know how and when to exit.
- Before entry, identify any physical hazards.
- Before and during entry, test and monitor for oxygen content, flammability, toxicity or explosive hazards as necessary.
- Use fall protection, rescue, air monitoring, ventilation, lighting and communication equipment according to entry procedures.
- Maintain contact at all times with a trained attendant either visually, via phone, or by two-way radio. This monitoring system enables the attendant and entry supervisor to order you to evacuate and to alert appropriately trained rescue personnel to rescue entrants when needed.

Refer to 29 CFR 1910.146 for complete regulations set by OSHA. Refer to your state's regulations if your state established and operates their own safety and health programs approved by OSHA.

# Package Contents

## GS Series



GS Core Unit  
75' or 150' Electric Cord  
(Not Pictured)



Cord Fixture



Chain Grab Tools



Lexel  
Sealant Tube



Kellem Grip  
Cord Strain Relief



1 5/16" Hole Saw



75' or 150'  
Stainless Steel  
Chain



Top of Tank  
Junction Box



Cord Seal

# Requirements

## GS Series Requirements - 120V

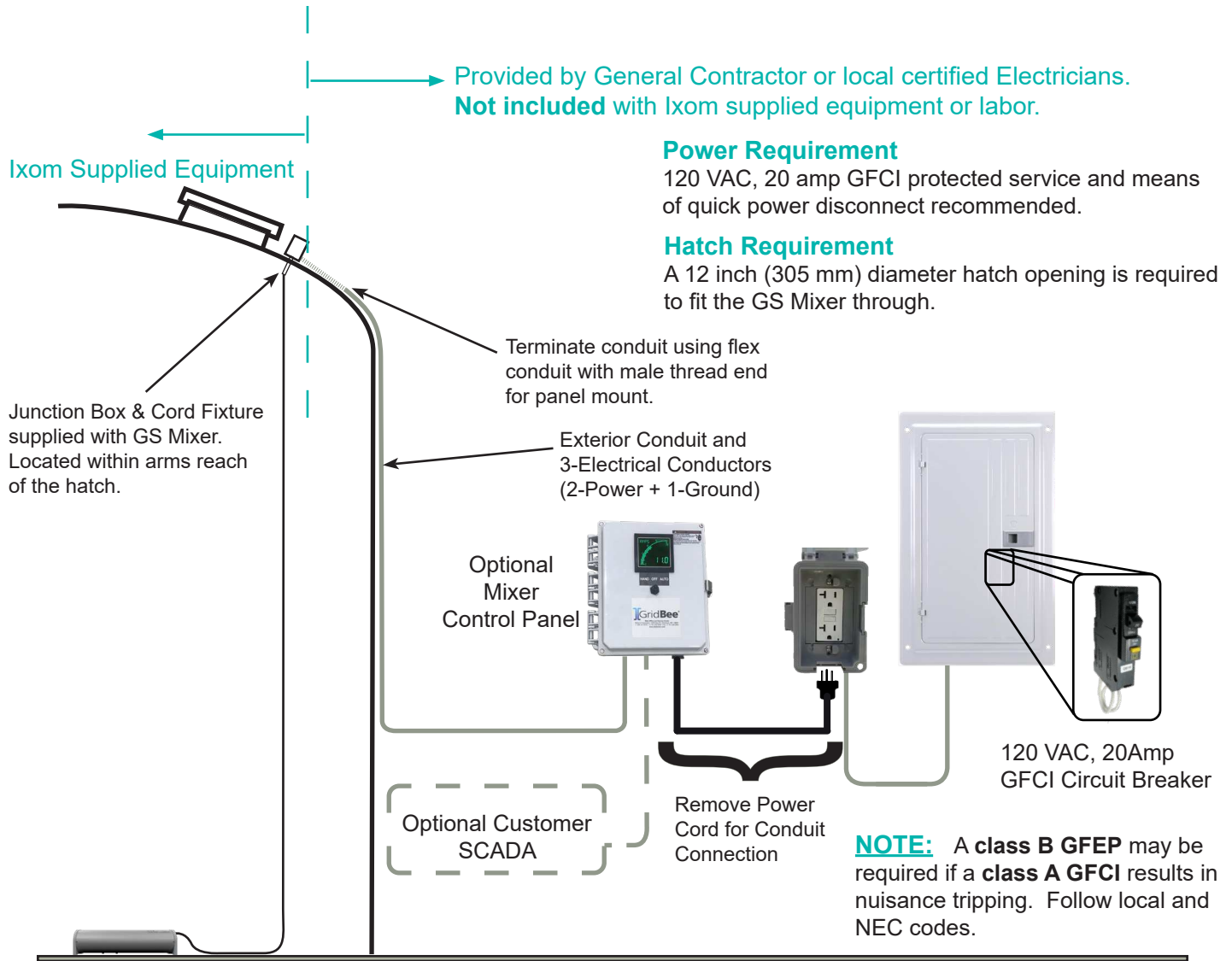

Figure 1: Typical GS Placement

RATING					FULL LOAD		MAXIMUM LOAD		WINDING (1) RES. IN OHMS	EFFICIENCY %		POWER FACTOR %		LOCKED ROTOR AMPS	KVA CODE
HP	KW	VOLTS	HZ	S.F.	(2) AMPS	WATTS	(2) AMPS	WATTS	M=MAIN RES. S=START RES.	F.L.	S.F.	F.L.	S.F.		
1/2	0.37	115	60	1.6	7.9	910	9.8	1120	1.4-2.0	42	54	99	99	28	H

(1) Main winding - yellow to black, Start winding - yellow to red

(2) Y = Yellow lead (White) - line amps, B = Black lead - main winding amps, R = Red lead - start or auxiliary winding amps

Service Entrance to Motor - Maximum Length In Feet Based on Service Factor Amps, and 5% Voltage Drop																
Motor Rating			60° C and 75° C Insulation - AWG Copper Wire Size													
Volts	HP	kW	14	12	10	8	6	4	3	2	1	0	00	000	0000	
115	1/2	0.37	100	160	250	390	620	960	1190	1460	1780	2160	2630	3140	3770	



# Top of Tank Junction Box

## Steel Roof

### GS Series

#### General Notes:

1. Top of tank junction box.
2. Cord seal fitting.
3. Brass nut.
4. Plastic seal washer with Lexel.
5. Tank penetration fitting.
6. A 1-5/16" dia. hole to be drilled into tank roof. Sealed with Lexel to protect from corrosion.
7. Strain Relief Washer.
8. Quick link for connecting retrieval chain and kellem grip to strain relief washer.
9. Kellem grip to support cable weight and to provide strain relief.

**NOT DESIGNED AS A SUBMERSIBLE PENETRATION.**

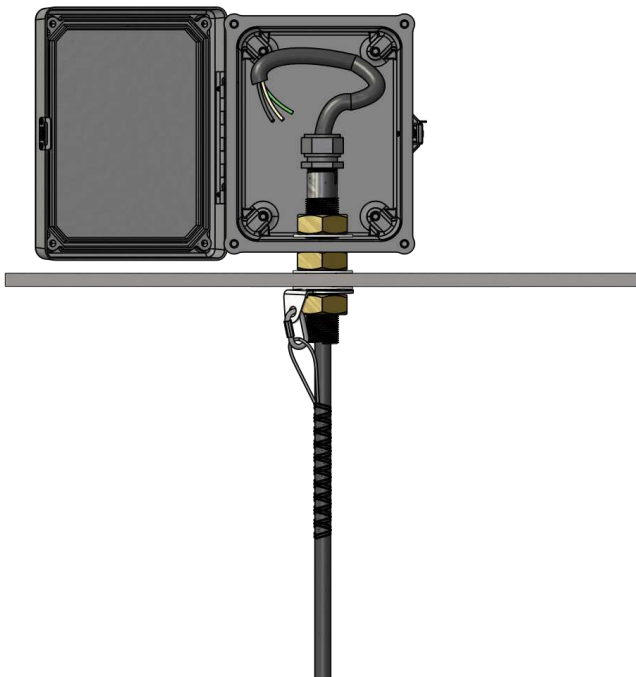
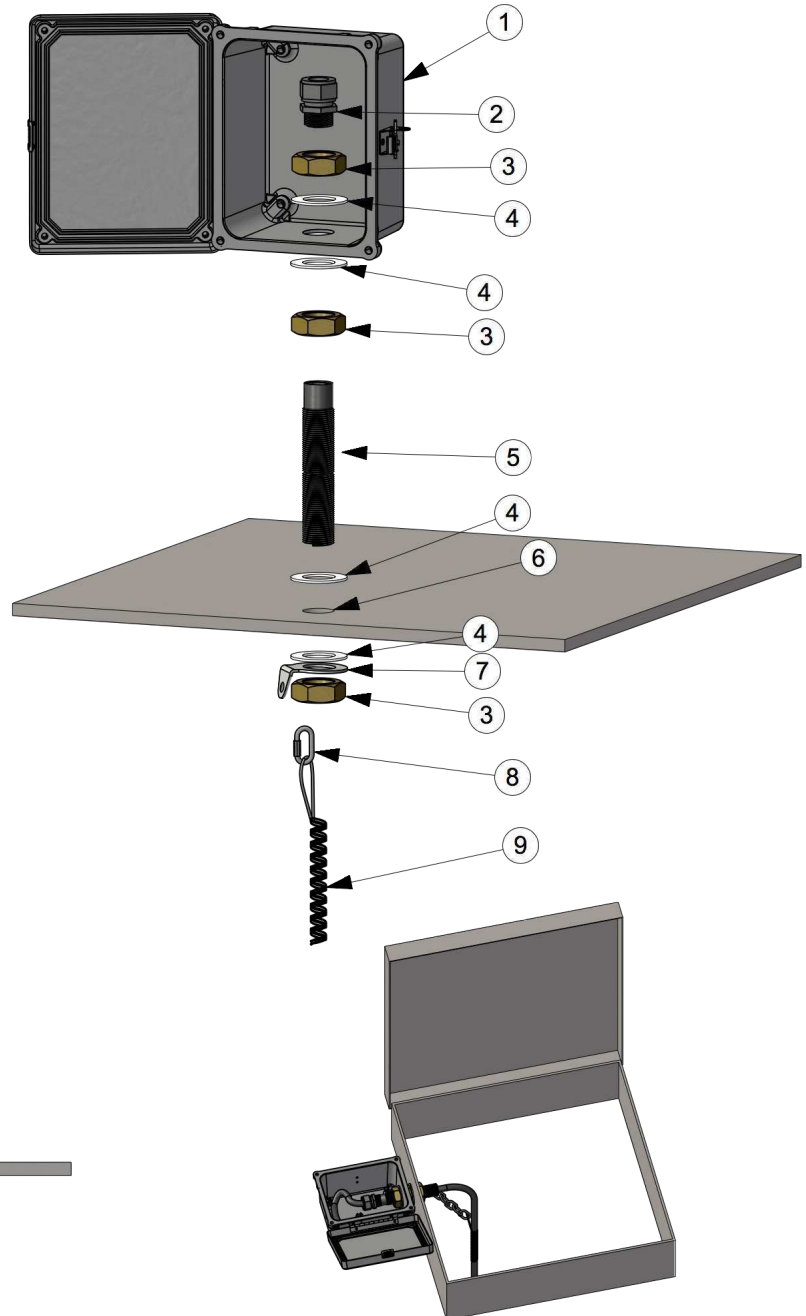

#### **Alternative Method:**

Penetration through hatch neck

#### **IMPORTANT NOTE:**

**Ensure penetration and junction box does not interfere with the hatch lid.**



# Top of Tank Junction Box

## Concrete Roof

### GS Series

#### General Notes:

1. Top of tank junction box.
2. Eye-bolt, epoxied into hatch neck, for retrieval chain and kellem grip.\*
3. Kellem grip.
4. Bolts, epoxied into hatch neck to secure concrete penetration fitting.
5. Concrete penetration fitting.\*
6. Small bores drilled into hatch neck the length of the bolts, 1/2" dia. typical, filled with concrete epoxy. Follow concrete epoxy manufacture's preparation and installation guidelines.
7. A 3/4" dia. minimum to 1-1/4" dia maximum hole drilled through hatch neck for electrical cord.
8. Junction box mounted to existing or new structure. Structure not included.
9. 3/4" NPT electrical conduit connection: conduit to junction box not included.

**\*Not included in standard contents  
Contact Ixom for  
exchange.**

**NOT DESIGNED AS A SUBMERSIBLE  
PENETRATION.**

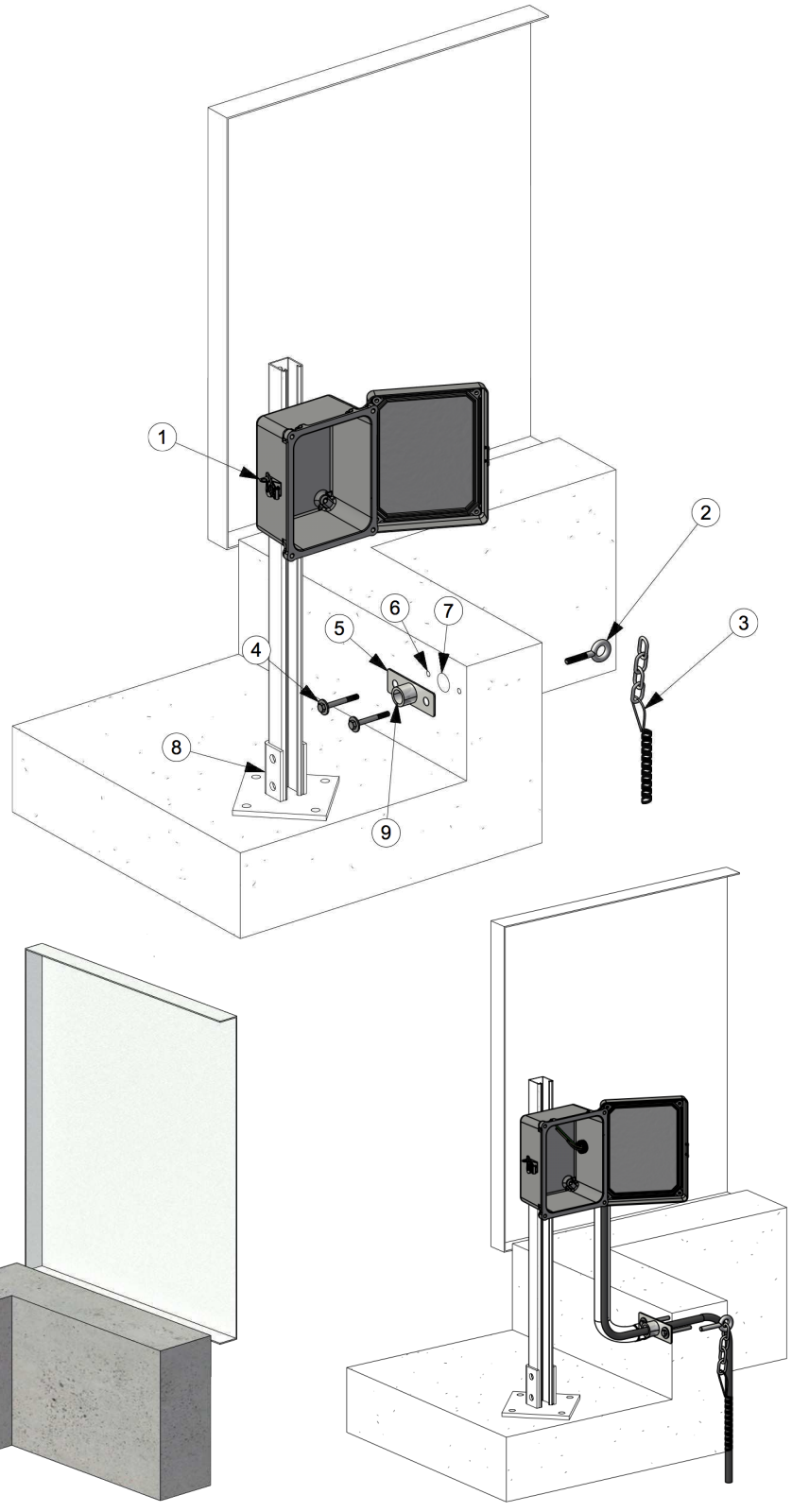

# Top of Tank Junction Box

## Aluminum Geodesic Dome Roof

### GS Series

#### General Notes:

1. Cord seal fitting.
2. Brass nut.
3. Plastic seal washer with Lixel.
4. Top of tank junction box.
5. Penetration fixture.
6. Aluminum geodesic dome panel.
7. Aluminum geodesic dome batten bar.
8. Support I-beam.
9. Quick link.
10. Kellem grip.
11. A 1-5/16" dia. hole drilled through panel and sealed with Lixel. Locate penetration within arms reach of an access point.
12. Eyebolt drilled through support I-beam to support kellem grip and retrieval chain. Eyebolt not included.

**NOT DESIGNED AS A SUBMERSIBLE PENETRATION.**

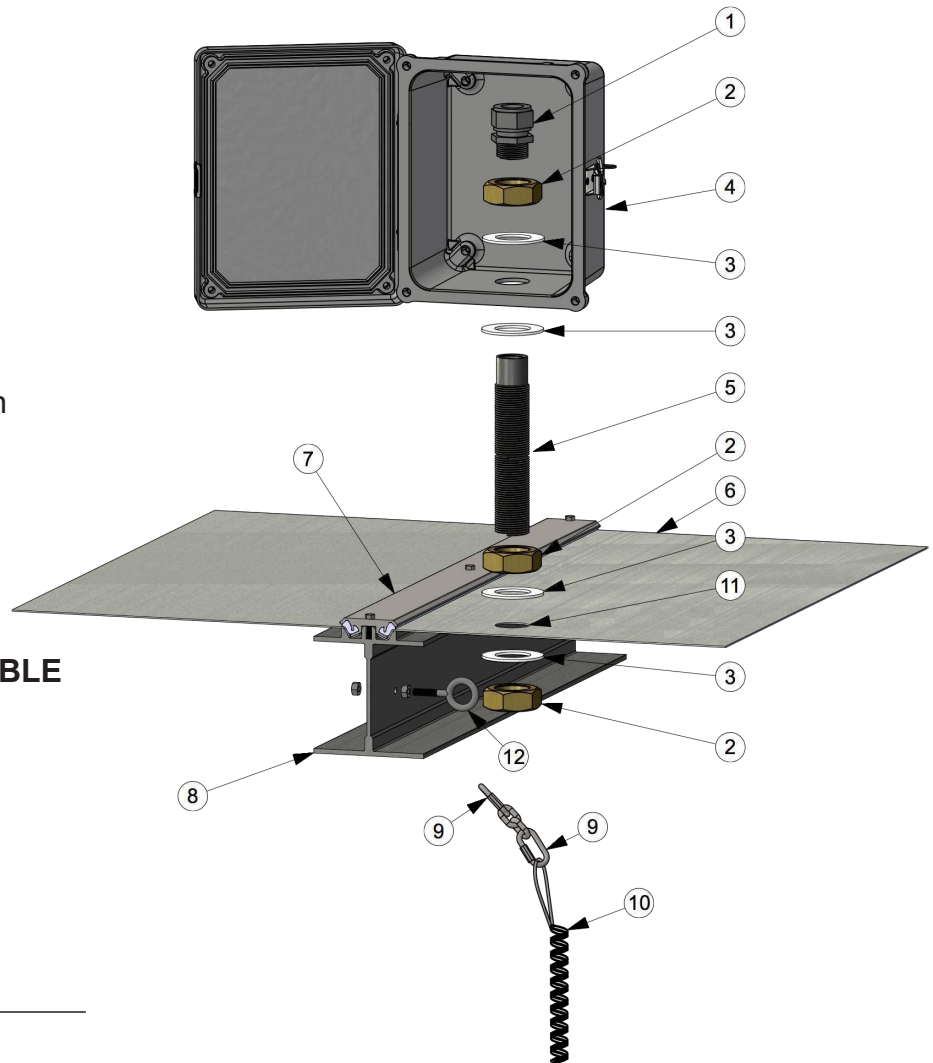
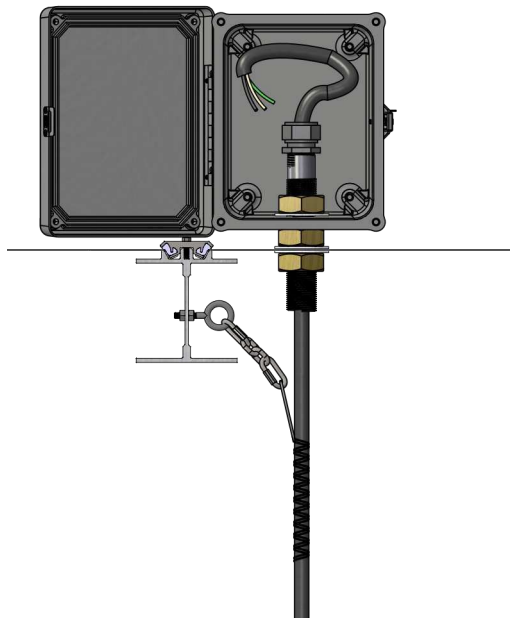

# Placement

## Floor Configuration

GS Series - Single Phase

Details listed on this page include items provided by Others, not Ixom. Please refer to your projects Scope of Work for more details. Ixom does not provide any electric work.

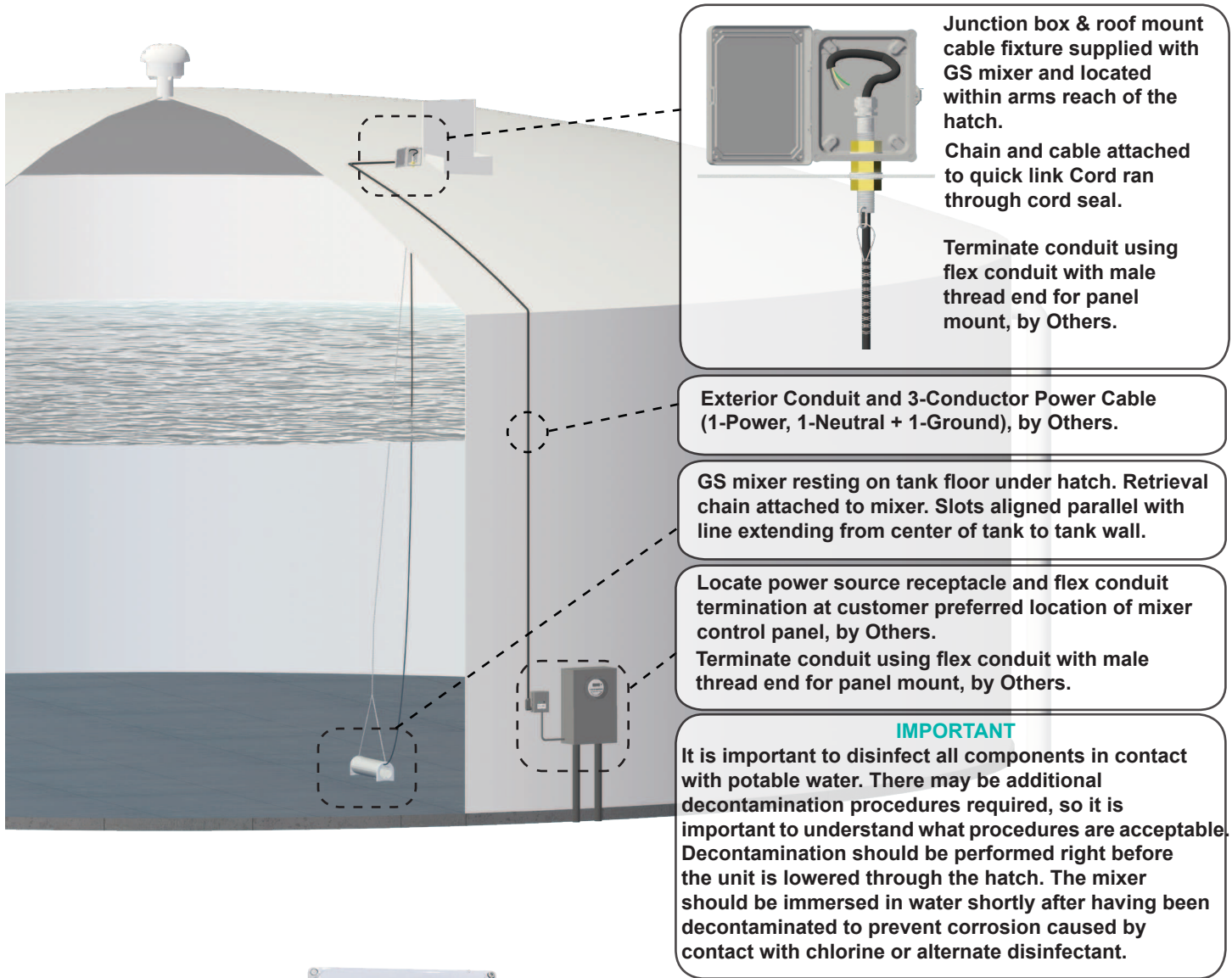

**GFCI Protected Source Power**



**Optional Mixer Control Panel**



**Junction Box & Tank Penetration**



**GS Mixer**

# Placement

## Suspended Configuration

GS Series - Single Phase

### Suspended Configuration

The suspended configuration is primarily used on tanks without a flat bottom. This method of installation is different with aluminum roofs or geodesic domed roofs.

### Installation Procedures

#### Step 1:

Attach the retrieval chain to the GS mixer at the pre-located quick link. Tighten the quick link with a wrench/pliers. Plan out a safe procedure and hoist the GS Mixer to the top of the tank near the hatch opening. Use the chain and submersible cable attached to the GS Mixer for lifting and supporting the weight. Keep clear of chain and electric cord to avoid entanglement.

#### Step 2:

Tie off the tail end of the retrieval chain and electric cord strain relief to the quick link at the bottom of the tank penetration fitting.

#### Step 3:

Pull the retrieval chain up until it is taught, then mark off the desired distance the GS Mixer is to be suspended above the floor, placing the quick link that desired distance down the retrieval chain below the tank penetration fitting.

#### Step 4:

Slowly pull up the GS Mixer and connect the quick link to the tank penetration fitting.

### IMPORTANT

It is important to disinfect all components in contact with potable water. A common practice is to use a minimum 200ppm chlorine or alternate disinfectant solution in water to spray all components that will contact the drinking water. There may be additional decontamination procedures required, so it is important to understand what procedures are acceptable. Decontamination should be performed right before the unit is lowered through the hatch. The mixer should be immersed in water shortly after having been decontaminated to prevent corrosion caused by contact with chlorine or alternate disinfectant.

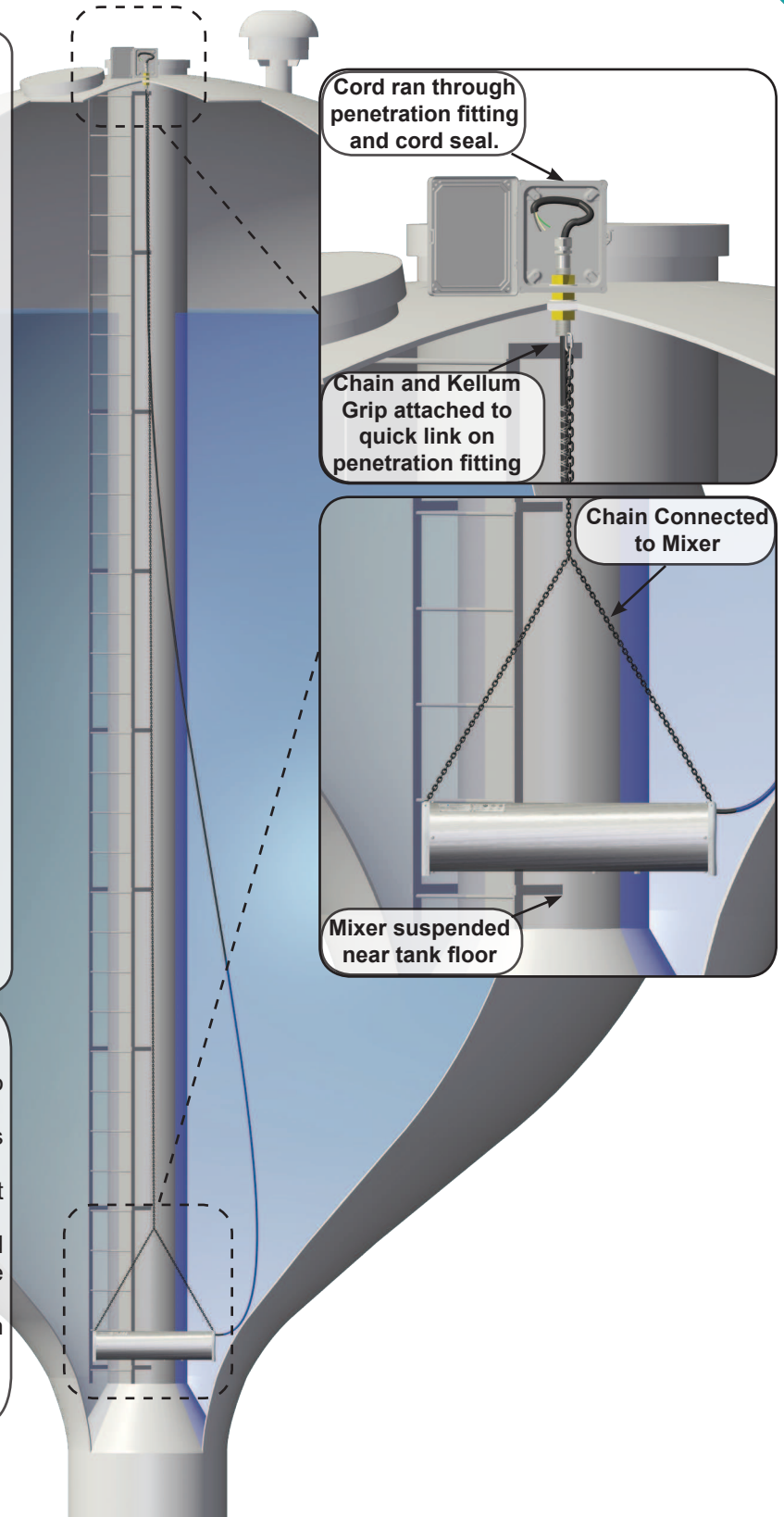



# Placement

## Mixer Placement Guidelines

### GS Series Mixers

In many cases, mixer deployment just below the main access hatch is sufficient. However, consider the below recommendations, where practical, for guidelines of mixer placement.

#### Short circuit path:

Ideally, the mixer should be placed in the short circuit path between the inlet and outlet of the tank. This provides the mixer the best opportunity to blend all incoming water with the tank volume prior to water exiting the outlet.

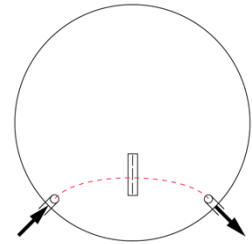

#### Common Inlet / Outlet:

The mixer should be favored toward a common inlet / outlet pipe to prevent short circuiting. This provides the mixer the best opportunity to blend all incoming water with the tank volume prior to water exiting the tank. However, the mixer should stay clear at least 10-15ft away from a common inlet/outlet pipe.

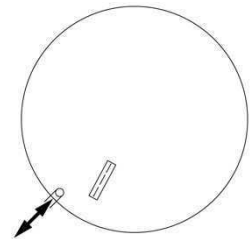

#### Radial Orientation:

It is best to orientate the mixer so the discharge slots are radial with the tank. This is most critical if the mixer is placed near a sidewall of the tank.

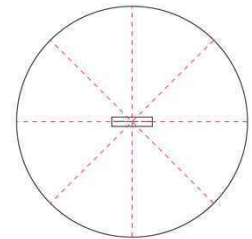

#### Center Tank Placement:

A mixer is often positioned at the tank center when a separate inlet and outlet are positioned at or approximately 180° apart. It is most critical for the mixer to be along a short circuit path.

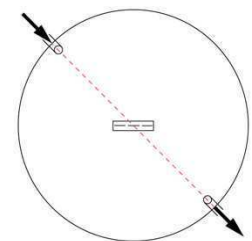

#### Mixer Elevation:

The mixer should be located in the lowest elevation of the tank, and resting or supported in a horizontal position with discharge slots pointed vertical. Water below the mixer will not be circulated.

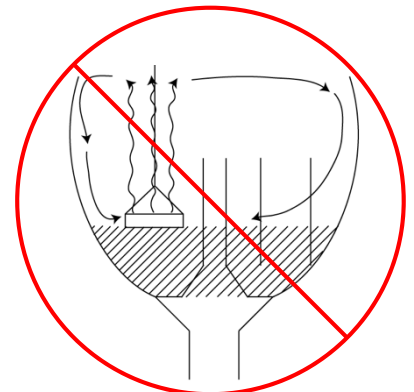
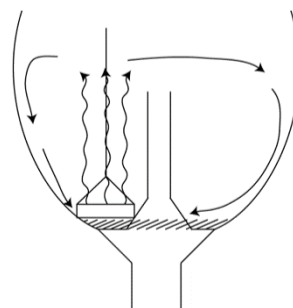

# Final Checklist

## GS Series Final Checklist

### Installation Checks

Before starting the GS Series mixer a few checklist items are recommended to confirm the installation is correct.

Installation Checks	Check
Is the mixer placed correctly with slots facing up? (Placement)	
Is the mixer retrieval chain connected securely? (Placement)	
Is the kelling grip supporting the weight of the cord/hose? (Placement)	
Is the cord/hose ran through the cord seal in the top of tank junction box? (Placement)	
Is the Tank Penetration fitting sealed with Lexel? (Top of Tank Junction Box)	
Are the top of tank junction box splices correct and each splice individually sealed to protect from corrosion? (Top of tank Junction Box) <b>(Not applicable for GS-12-Air)</b>	
Is the field wiring correct? (Requirements)	
Is the mixer submerged with at least 2' (0.75m) of water above the discharge slots?	

Pre Operation Checks	Reading	
Continuity Check	Line to Neutral:	
	Line to Ground:	
	Neutral to Ground:	
Source Voltage Reading		

### Operation Checks

The following checklist items are recommended to confirm proper operation.

Operation Check (While Mixer is Running)	Reading / Observation
Source Voltage Reading	
Amperage Reading Normal Operating Range: (7.5 amps to 10.0 amps)	
Flow Check Auditory	
Flow Check Visual	

# Troubleshooting

## GS Series

(For Optional Mixer Control Panel)



### Voltage (V̄)

To measure the voltage follow these steps.

1. Set the voltmeter on Volts AC.
2. Place the positive probe on the black wire and the negative probe on the white wire on the top of the contactor (source side).
3. Record the reading.

### Amperage (Ā)

To Measure the Amperage follow these steps.

1. Use a clamp type ammeter, set to Amps AC.
2. Clamp around the black wire on the bottom of the contactor (load side). Marked Load 1 (L1).
3. Record the reading with mixer turned on.

### Ohms (Ω)

To Measure the Ohms follow these steps.

1. Turn off the circuit breaker feeding the control panel and follow lock out tag out procedures.
2. Measure the Voltage to confirm that the power is removed.
3. Disconnect the black and white wires from the bottom of the contactor (load side). Marked Load 1 (L1) and Neutral (N).
4. Set the Voltmeter to Ohms.
5. Place the positive probe on the black wire and the negative probe on the white wire that were disconnected.
6. Record the reading.

Depending on the length and gauge of wires to the mixer the ohms should be approximately:

1-4 Ohms, 120V and 6-10 Ohms, 230V.

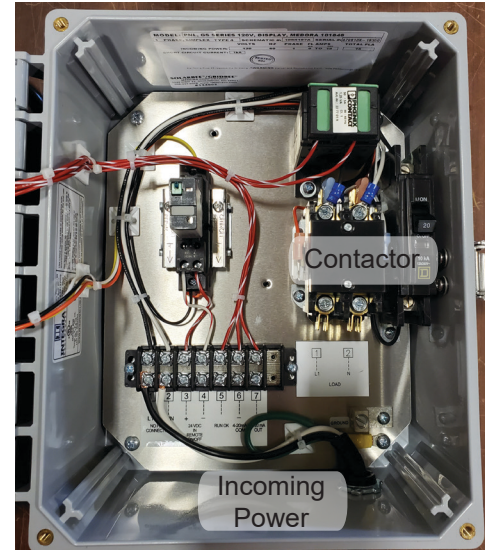

Figure 1: SCADA Control Panel



Figure 2: Disconnect Control Panel

Troubleshooting Information	
Serial Number	
Location Name	
Tank Name	
Distributor Name (if applicable)	
Voltage Reading	
Amperage Reading	
Ohm Reading	

Problem	Possible Cause
Mixer Intermittently Tripping Circuit Breaker	Multiple GFCI on Circuit Source Power Fluctuation
Mixer Quickly Tripping Circuit Breaker	Short to Ground Locked Rotor on Motor
Mixer Not Operating but Circuit Breaker not tripped	Loose or Loss of Connection
Mixer Making Loud Noise	Motor Bearing Failure Impeller Misalignment



## GS Series

### GS Mixer End Plate Removal and Impeller Visual

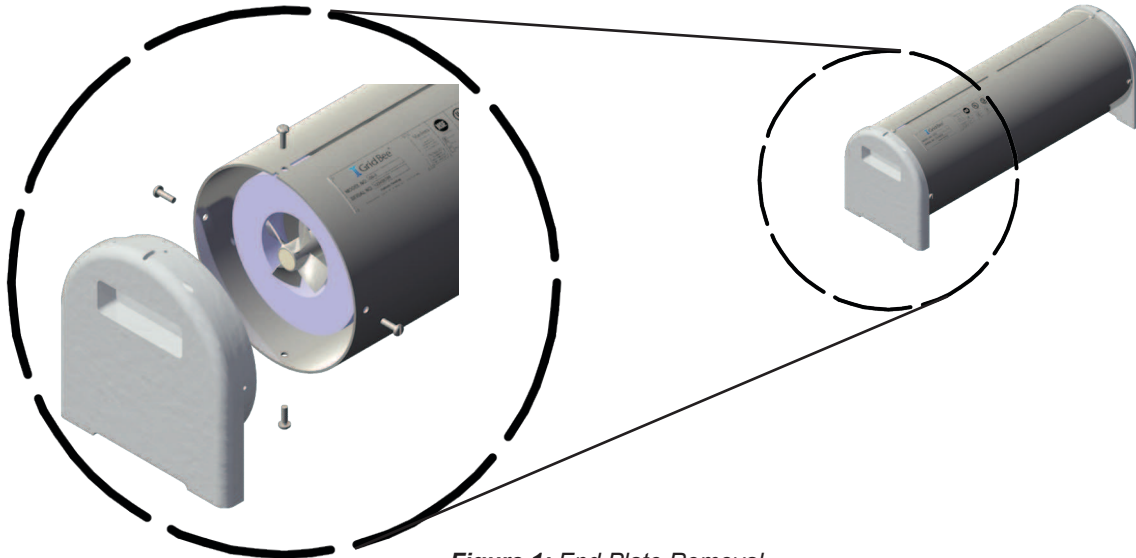

Figure 1: End Plate Removal

#### Step 1

Isolate power to the GS mixer to prevent it from turning on during inspection. The mixer must be off to perform this inspection safely.

#### Step 2

Remove white end plate on the end of GS Mixer. The side that should be removed is the side without the screen on it. You will find four (4) screws that will need to be removed in order for the end plate to become free from the mixer. (See Figure 1)

#### Step 3

Visually inspect the impeller for debris or build up. You should be able to move the impeller freely with no resistance. (See Figure 2)

#### Step 4

Remove any debris if necessary.

#### Step 5

Place the white end plate back on the GS Mixer, ensuring to line up the notch on the top side of the mixer. The four screws that were removed in Step 2 should be put back in place at this point as well.

#### Tools Needed

1. Electric Drill
2. #3 Phillips drill bit

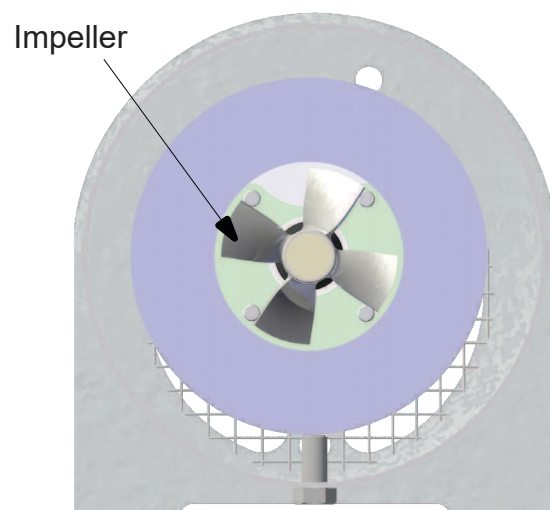

Figure 2: Impeller View

# Technical Data Sheet

## GS-12

### 120VAC Single Phase

**Technology Description-** GridBee® electric submersible water circulation equipment, designed for continuous operation. Constructed with T316 stainless steel shell and safe materials for contact with potable drinking water. Designed to be placed into service through roof hatch without tank entry.

**Materials of Construction** - T316 stainless steel shell and hardware construction. UHMW-PE end plates for worry-free safe contact with all tank surfaces. See certifications section below.

75 ft (22 m) or 150 ft (44 m) of T316 stainless steel retrieval chain included for machine installation and retrieval without requiring tank entry.

**Minimum Access Opening** - Machine can be placed through 12 inch (30 cm) diameter opening.

**Minimum Water Depth** - The mixer requires at least 2 feet (0.6 meters) of water above the discharge slots to prevent pump cavitation and motor damage. Shut the mixer off if water surface is less than 2ft from the mixer slots.

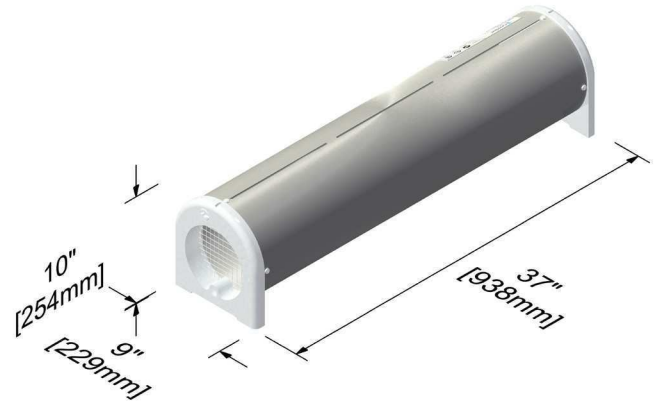

Figure 1: GS-12

**Intake** - Intake draws water in a horizontal layer within 2 inches (5.08 cm) of the tank or reservoir floor. Chlorine boost connection point on machine via 3/8" NPT female thread for adapting to 1/2" (13mm) hose for fast chlorine dispersion during in-reservoir boosting.

**Electrical Requirements** - 120VAC motor requires 120VAC/1PH power source outlet (**20 Amp GFCI service is required**). The GS-12 draws approximately 9.8 Amps @ 120VAC / 60Hz. Nominal power consumption of 1120 Watts.

**Motor** - 1/2 HP stainless steel submersible, designed for continuous operation, low power requirement, direct drive, no gearbox and no lubrication schedule required. Automatic reset, on-winding thermal overload protection and surge arresters built in. Mounted in flow sleeve for superior cooling and long motor life in submerged temperatures up to 122 F. See certifications section below. 120VAC/1PH standard, other voltages available as special order.

**Wiring** - Includes either 75 ft (22 m) or 150 ft (44m) of 10AWG submersible power cable to terminate within junction box at top of tank. Junction box included.

**Sealed Penetration Fitting** - T316 stainless steel tank fitting and cord grip included for sealed cord entry through tank roof. Not designed as a submersible penetration.

**Optional Accessories** - (1) Portable Chlorine Boost Hose and Boost Pump System, (2) Dual Injection Kit, (3) Control and SCADA Panel

#### Shipping Size / Weight

- 75 ft unit** - Box 1 of 2: 44x16x12 in. / 88 lbs, Box 2: of 2: 17x13x8 in. / 25 lbs: Total shipment weight: 123 lbs
- 150 ft unit** - Box 1 of 2: 44x16x12 in. / 127 lbs, Box 2: of 2: 17x13x8 in. / 41 lbs: Total shipment weight: 168 lbs

**Certifications** - Ixom's potable water products are certified to NSF/ANSI/CAN 61-G & 372 for lead-free content. Learn more at: [www.ixomwatercare.com/std61](http://www.ixomwatercare.com/std61)

**Maintenance / Warranty** - Limited maintenance. Limited 5-year parts and labor warranty. See Warranty Statement for details.

## Warranty



# GridBee GS Submersible Mixer

## Limited Replacement Warranty

**GridBee GS Mixers.** The GridBee Series GS mixers are warranted to be free of defective parts, materials, and workmanship for a period of five years from the date of purchase. This warranty is valid only for use of the equipment in accordance with the owner's manual and any initial and ongoing factory recommendations. This warranty is limited to the repair or replacement of defective components only and does not apply to normal wear and tear. If the factory's service crews performed the original on-site placement and startup, then this warranty also includes labor. Where labor is included, in lieu of sending a factory service crew to the site for minor repairs, Ixom may choose to send the replacement parts to the owner postage-paid and may pay the owner a reasonable labor allowance, as determined solely by Ixom, to install the parts. There is no liability for consequential damages of any type. The warranty that is submitted and provided with the purchased equipment is the valid warranty.

**GridBee control panels, cold weather hose kits, air compressors and any optional accessories.** These items are considered "buyout" items for Ixom, and as such include a warranty against defects in material and workmanship for one year from the date of purchase. This warranty covers parts only, not labor. Parts that are determined by Ixom to be defective in material or workmanship under normal use during the one year warranty period will be repaired or replaced. Shipping charges are the responsibility of the customer.

**Terms applicable to all equipment.** This Limited Replacement Warranty is subject to the terms of Ixom's General Terms and Conditions of Sale. In the event of any inconsistency between the terms of this Limited Replacement Warranty and Ixom's General Terms and Conditions of Sale, the terms of this Limited Replacement Warranty shall prevail to the extent of that inconsistency.

# Protect Your Investment With The Ixom Service Program

## Comprehensive Damage Repair

Damage which occurs to your Ixom manufactured equipment in the normal course of operation will be repaired or replaced including supply and installation of structural repairs and replacement parts in accordance with Ixom's standard terms & conditions.

## Trained & Experienced Service Technicians

The Ixom Service Program allows our customers to take advantage of our highly trained service technicians. We have the equipment, experience and training to ensure the machines are well maintained while following OSHA regulations. Our dedication to safety and high level of training has earned us the prestigious SHARP recognition award time and time again. We have the means to safely service the equipment whether in municipal water tanks, lakes, reservoirs, or wastewater ponds & basins.



## Guaranteed Annual Onsite Maintenance

Ixom service personnel will perform a minimum of one (1) onsite equipment inspection & maintenance per yearly term of the service contract including mechanical, structural, and electronic components of Ixom manufactured equipment.

## On-Site Crew Response for Critical Application and Operational Service Issues

If service issues arise, the customer may be asked to perform a basic machine inspection and discuss results with Ixom's Customer Service Department. In some cases, the customer may be asked to perform minor tasks (i.e., cleaning, basic troubleshooting, and replacing minor parts). If replacement parts are needed, the factory will ship them out at no cost. For more serious application and service issues, Ixom will dispatch service personnel to resolve the issues onsite.



## Removal, Storage, and Redeployment of Equipment

For situations when Ixom equipment needs to be removed, stored, and redeployed, services can be offered at a discounted rate.

## Access to On-Staff Water Quality Experts

Ixom employs many experts in the water quality field including specialized areas such as limnology, hydrology, wastewater, biology, and engineering. Our water quality personnel are available for data analysis and troubleshooting when you need it.



**Contact us for a quote!**

Call +1 866-437-8076 or email us at [watercare@ixom.com](mailto:watercare@ixom.com)



# IXOM

## WATERCARE

## Nationwide Installation & Service

### EVERYONE DESERVES GREAT CUSTOMER SUPPORT

Ixom Watercare earns customer trust with unparalleled service start to finish. Every department in Ixom is dedicated to the support of our Customers and the improvement of water quality. Complete life cycle support is much, much more than a returned phone call or an email. It centers around direct access and communication to those who can help when help is needed from the beginning of a project throughout the life of the equipment.

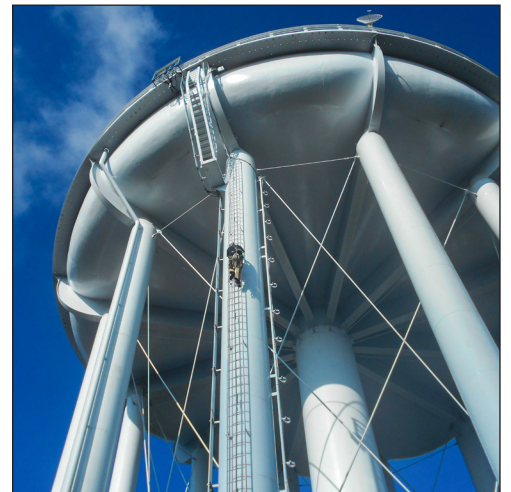

### ABOUT IXOM

Ixom combines innovative water quality solutions with top notch manufacturing and nationwide in-field service capabilities to create trusted, full circle support our Customers depend on.

We design and manufacture many trusted brands including GridBee®, SolarBee®, MIEX®, and ResidualHQ® for use across the water quality spectrum. This includes solutions for Water Treatment, Distribution Treatment, Wastewater Treatment and Lakes & Source Water Reservoirs.

Ixom has thousands of installations and is an industry-leader solving water quality problems across the United States, Canada and the world.

**Contact us today to discuss your water quality and service needs.**

[ixomwatercare.com](http://ixomwatercare.com)  
866-437-8076 • [watercare@ixom.com](mailto:watercare@ixom.com)