

Technical Data Sheet

SB10000DM

Technology Description- Floating, solar powered, circulation equipment. Two mixing flows for maximum nutrient (N and P) reduction, in addition to BOD/TSS reduction in partial mix and facultative wastewater treatment systems. Day/night operation on solar only by utilizing a battery to store a battery to store excess daytime power for nighttime operation.

Materials of Construction - T316 stainless steel construction. Foam-filled high-density polyethylene (HDPE) floats. Thermoplastic rubber stainless steel reinforced intake hose. HDPE strainer. Concrete mooring blocks are encapsulated in HDPE.

Machine Size / Weight - Assembled machine is 16 feet (5 m) in diameter and weighs 850 pounds (380 kg).

Drive System - High torque, direct drive (no gearbox), low voltage brushless D.C. motor.

Minimum Operating Depth - 36 inches (0.9 m). No damage to machine or bottom of reservoir when run dry in shallow water.

Flotation System - Three floats in triangular pattern each with an adjustable float arm for proper vertical positioning, total float buoyancy of 1,450 lbs (660 kg).

Rotating Assembly - Removable assembly with easy access to motor and digital controller. Impeller handles 4-inch (10 cm) spherical solids. Oil-filled (food grade) teflon freeze sleeve with o-rings, shaft. Rotational indicator on shaft.

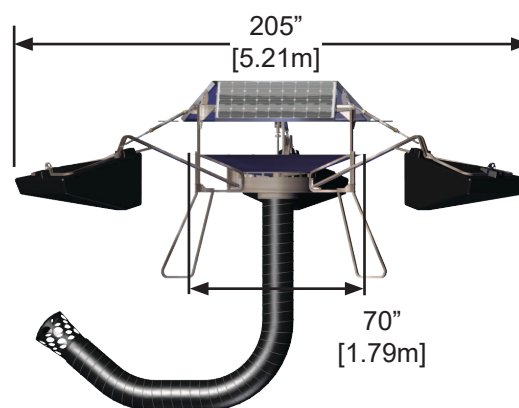

Figure 1: SB10000DM

Power Supply/Control System - *Photovoltaic (PV) Solar Panels are protected from bird fouling with bird deterrent kit.*

PV Solar Panels: 3 X 80-watt photovoltaic solar panels. Onboard battery storage for day/night operation.

Electronic Controller: Digital solid-state controller, mounted in weather-tight (NEMA 4X) enclosure with externally fused disconnect. SCADA output through RS-232 serial communication (Modbus RTU), DB9 male connection point inside enclosure. Wireless options available, not included.

Wiring: Corrosion-resistant industrial cord with molded watertight connectors that are indexed to prevent improper wiring.

Flow Rates - *Flow Rates at full speed at 10 feet (3.0 m) diameter.*

Direct Flow Rate: 3,000 gallons per minute (12,000 liters per minute).

Induced Flow Rate: 7,000 gallons per minute (26,000 liters per minute).

Combined Flow Rate: 10,000 gallons per minute (38,000 liters per minute).

Lower Mixed Zone Flow Rates - *Flow Rates at full speed at center of machine..*

Direct Flow Rate - Day: 150 gallons per minute. (600 liters per minute).

Direct Flow Rate - Night: 150 gallons per minute. (600 liters per minute).

Fluid Intake Assembly - Lower Mixed Zone - *Intake hose assembly bolted to bottom of structural assembly.*

Hose System: 12 inch (31 cm) diameter X 20 feet (6 meter).

Intake Type: Inverted bell shape strainer with 3 inch (7.6 cm) holes.

Intake Depth Adjustment: There is no adjustment necessary for fluctuations in water level. Weight and flotation of the 'J' bend of hose keeps intake above sludge at all operation depths. Strainer can be chained up higher if desired.

Fluid Intake Assembly - Upper Mixed Zone - *Fixed horizontal plate bolted to bottom of structural assembly.*

Intake Type: Fixed horizontal plate with 12-inch (31 cm) openings.

Intake Depth Adjustment: No adjustment necessary. Horizontal inflow from 25-inch (64 cm) below distribution dish.

Anchoring - (1) Two mooring blocks tethered together with SS chain and attached to structural member on unit or
(2) Tethered to shore with SS cable.

Ice Protection - Freeze sleeve and positive pumping under distribution dish to maintain circulation.

Accessories Available - (1) Supplemental Shore Power Kit, (2) Chemical Injection Kit, (3) Marker Light Kit

Shipping Size / Weight -

• **Crate** - 87 inch W X 87 inch L X 65 inch H (2.2 m x 2.2 m x 1.7 m) / 1,500 pounds (680 kg)

Exact weight and dimensions varies dependent on machine configuration.

Maintenance / Warranty - Minimal maintenance. Limited 2-year parts and labor warranty.