

# Technical Data Sheet

## SB5000

**Technology Description**- Floating, solar powered, circulation equipment for wastewater treatment and freshwater applications. Day/night operation on solar only by utilizing a battery to store excess daytime power for nighttime operation.

**Materials of Construction** - T316 stainless steel construction. Foam-filled high-density polyethylene (HDPE) floats. Thermoplastic rubber intake hose. HDPE strainer. Concrete mooring blocks are encapsulated in HDPE.

**Machine Size / Weight** - Assembled machine is 16 feet (5 m) in diameter and weighs 850 pounds (380 kg).

**Drive System** - High torque, direct drive (no gearbox), low voltage brushless D.C. motor.

**Minimum Operating Depth** - 31 inches (0.8 m) with fixed horizontal plate. No damage to machine or bottom of reservoir when run dry in shallow water.

**Flotation System** - Three floats in triangular pattern each with an adjustable float arm for proper vertical positioning, total float buoyancy of 1,450 lbs (660 kg).

**Rotating Assembly** - Removable assembly with easy access to motor and digital controller. Impeller handles 4-inch (10cm) spherical solids. Oil-filled (food grade) teflon freeze sleeve with o-rings, shaft. Rotational indicator on shaft.

**Power Supply/Control System** - *Photovoltaic (PV) Solar Panels are protected from bird fouling with bird deterrent kit.*

**PV Solar Panels:** 3 X 80-watt photovoltaic solar panels. Onboard battery storage for day/night operation.

**Electronic Controller:** Digital solid-state controller, mounted in weather-tight (NEMA 4X) enclosure with externally fused disconnect. SCADA output through RS-232 serial communication (Modbus RTU), DB9 male connection point inside enclosure. Wireless options available, not included.

**Wiring:** Corrosion-resistant industrial cord with molded watertight connectors that are indexed to prevent improper wiring.

**Flow Rates** - *Flow Rates at full speed at 10 feet (3.0 m) diameter.*

**Direct Flow Rate:** 700 gallons per minute (2,650 liters per minute).

**Induced Flow Rate:** 4,300 gallons per minute (16,300 liters per minute).

**Combined Flow Rate:** 5,000 gallons per minute (18,950 liters per minute).

**Fluid Intake Assembly - Option 1** - *Intake hose assembly bolted to bottom of structural assembly.*

**Intake Type:** Fixed horizontal plate with 12-inch (31 cm) openings.

**Intake Depth Adjustment:** Can vary from 0 to 60 feet (0 to 18 m). No depth adjustment necessary for fluctuations in water level. Weight and flotation of the 'J' bend of hose keeps intake above sludge or bottom of pond at all operating depths. Strainer can be chained up higher if desired.

**Fluid Intake Assembly - Option 2** - *Fixed horizontal plate bolted to bottom of structural assembly.*

**Intake Hose :** 20 to 60 feet (6 to 18 m) available in 16-inch (40 cm) diameter X 20 feet (6 m) sections.

**Intake Type:** Inverted bell shape strainer with 4-inch (10 cm) holes.

**Intake Depth Adjustment:** No adjustment necessary. Horizontal inflow from 25-inch (64 cm) below distribution dish.

**Anchoring** - (1) Two mooring blocks tethered together with SS chain and attached to structural member on unit or  
(2) Tethered to shore with SS cable.

**Ice Protection** - Freeze sleeve allows shaft to rotate while ice is formed around sleeve.

**Accessories Available** - (1) Supplemental Shore Power Kit, (2) Chemical Injection Kit, (3) Marker Light Kit

**Shipping Size / Weight** -

- **Crate** - 87 inch W X 87 inch L X 65 inch H (2.2 m x 2.2 m x 1.7 m) / 1,500 pounds (680 kg)

*Exact weight and dimensions varies dependent on machine configuration.*

**Maintenance / Warranty** - Minimal maintenance. Limited 2-year parts and labor warranty.

Patent Pending

Subject to change without notice.

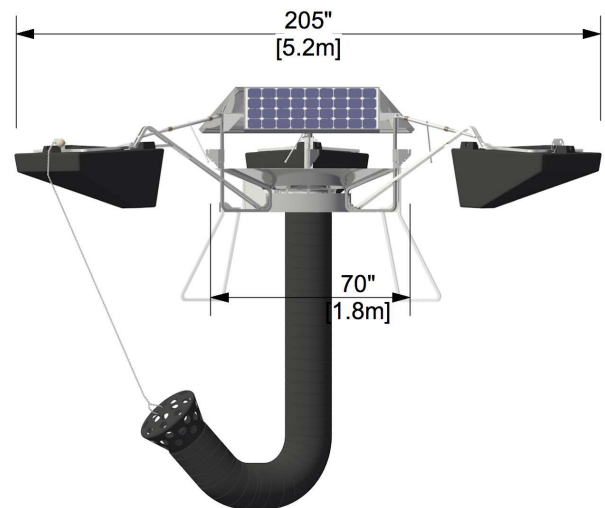

Figure 1: SB5000